

RAINURES EN T  SUR MACHINES-OUTILS DIMENSIONS - ISO 299 / DIN 650

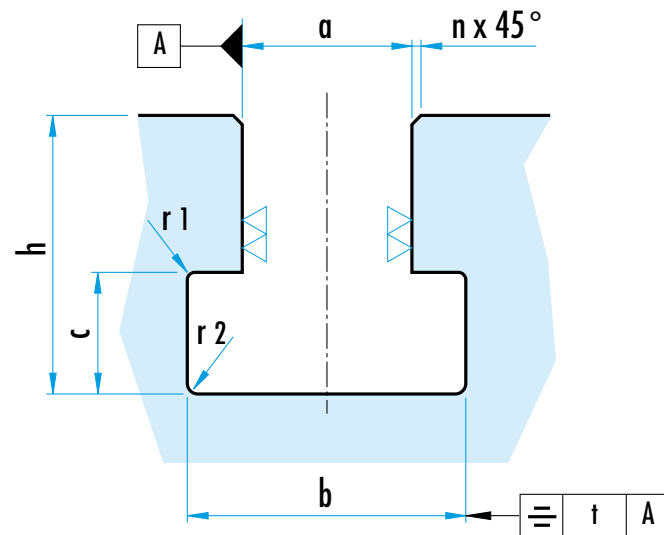
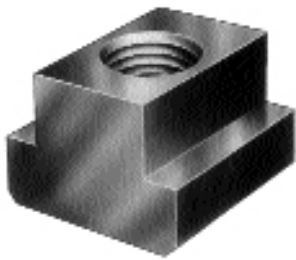

a	b	c	h		n max.	r1 max.	r2 max.	t
			max.	min.				
5	10 ^{+1 0}	3 ^{+0,5 0}	10	8	1	0,8	1	0,5
6	11 ^{+1,5 0}	5 ^{+1 0}	13	11				
8	14,5 ^{+1,5 0}	7 ^{+1 0}	18	15				
10	16 ^{+2 0}	7 ^{+1 0}	21	17				
12	19 ^{+2 0}	8 ^{+1 0}	25	20				
14	23 ^{+2 0}	9 ^{+2 0}	28	23	1,6	1	1,6	2,5
18	30 ^{+2 0}	12 ^{+2 0}	36	30				
22	37 ^{+3 0}	16 ^{+2 0}	45	38				
28	46 ^{+4 0}	20 ^{+2 0}	56	48	2,5	1,6	4	1
36	56 ^{+4 0}	25 ^{+3 0}	71	61				
42	68 ^{+4 0}	32 ^{+3 0}	85	74				
48	80 ^{+5 0}	36 ^{+4 0}	95	84				
54	90 ^{+5 0}	40 ^{+4 0}	106	94				

ECROU EN Té ISO 299 / DIN 508

H.23010.0

ALU
SUR DEMANDE

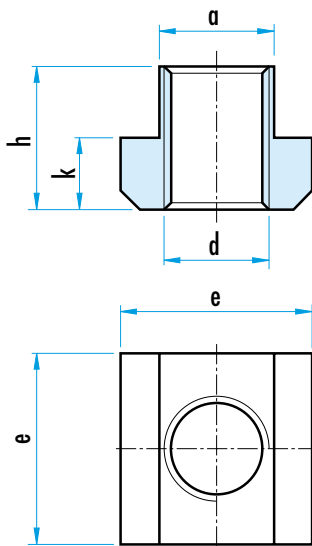

SUR DEMANDE : écrou en Vé

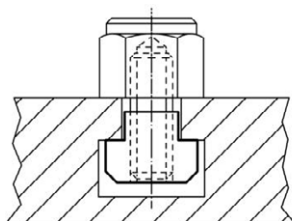

MATIERE : acier traité.

EXECUTION : qualité 10 - noirci.

REMARQUE : les dimensions avec (*) ne font pas partie de la norme DIN.

Sur demande :

- qualité 8 - naturel,
- dimensions "inch" (Ref. WWN.664)
- en aluminium.

Ø d	DIN 650 rainure	a	e	h	k	poids (g)	Ref.
M4	5	4,6	9	6,5	3	1	H.23010.0052
M5	6	5,6	10	8	4	3	H.23010.0062
M6	8	7,6	13	10	6	8	H.23010.0082
M6(*)	10	9,6	15	12	6	14	H.23010.0104
M8	10	9,6	15	12	6	14	H.23010.0102
M8(*)	12	11,6	18	14	7	22	H.23010.0124
M10	12	11,6	18	14	7	22	H.23010.0122
M8(*)	14	13,6	22	16	8	34	H.23010.0145
M10(*)	14	13,6	22	16	8	34	H.23010.0144
M12	14	13,6	22	16	8	34	H.23010.0142
M8	16	15,6	25	18	9	62	H.23010.0166
M10	16	15,6	25	18	9	58	H.23010.0165
M12(*)	16	15,6	25	18	9	50	H.23010.0164
M14	16	15,6	25	18	9	50	H.23010.0162
M8	18	17,6	28	20	10	90	H.23010.0187
M10	18	17,6	28	20	10	85	H.23010.0186
M12(*)	18	17,6	28	20	10	68	H.23010.0185
M14(*)	18	17,6	28	20	10	68	H.23010.0184
M16	18	17,6	28	20	10	68	H.23010.0182
M12(*)	20	19,6	32	24	12	107	H.23010.0205
M16(*)	20	19,6	32	24	12	107	H.23010.0204
M18(*)	20	19,6	32	24	12	107	H.23010.0202
M12(*)	22	21,6	35	28	14	155	H.23010.0225
M16	22	21,6	35	28	14	175	H.23010.0226
M18(*)	22	21,6	35	28	14	155	H.23010.0224
M20	22	21,6	35	28	14	155	H.23010.0222
M16	24	23,6	40	32	16	250	H.23010.0246
M20(*)	24	23,6	40	32	16	220	H.23010.0244
M22(*)	24	23,6	40	32	16	220	H.23010.0242
M16	28	27,6	44	36	18	375	H.23010.0286
M20	28	27,6	44	36	18	360	H.23010.0284
M22	28	27,6	44	36	18	345	H.23010.0283
M24	28	27,6	44	36	18	330	H.23010.0282
M27(*)	32	31,5	50	40	20	460	H.23010.0322
M24	36	35,5	54	44	22	600	H.23010.0364
M30	36	35,5	54	44	22	600	H.23010.0362
M36	42	41,5	65	52	26	1000	H.23010.0422
M42	48	47,5	75	60	30	1500	H.23010.0482
M48	54	53,4	85	70	34	2100	H.23010.0542

ECROU EN TE EN INOX ISO 299 / DIN 508

H.23010.0



MATIERE : INOX 1.4305

d	DIN 650 rainure	a	e	h	k	poids (g)	Ref.
M6	8	7,6	13	10	6	8	H.23010.0721
M8	10	9,6	15	12	6	14	H.23010.0731
M10	12	11,6	18	14	7	22	H.23010.0741
M12	14	13,6	22	16	8	34	H.23010.0751
M14	16	15,6	25	18	9	50	H.23010.0761
M16	18	17,6	28	20	10	68	H.23010.0781

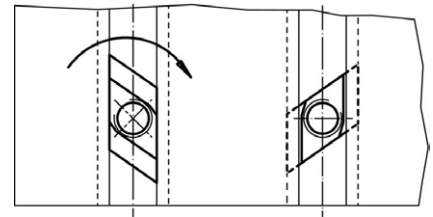
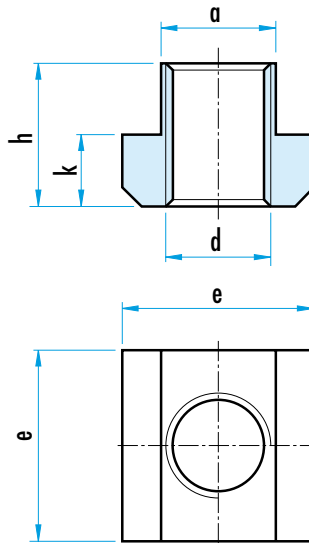

ECROU EN Té SANS TARAUDAGE DIN 508.R

H.23010.0

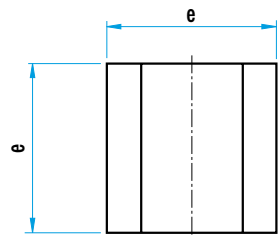
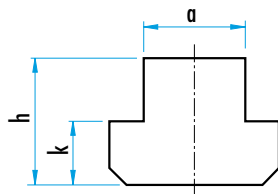

MATIERE : acier traité.

EXECUTION : naturel.

REMARQUE : Permet la réalisation d'écrous en Té "hors standard".

Sur demande :

- dimensions "inch" (WWN.664),
- en aluminium.

rainure	a	e	h	k	poids (g)	Ref.
6	5,6	10	8	4	4	H.23010.0060
8	7,6	13	10	6	10	H.23010.0080
10	9,6	15	12	6	16	H.23010.0100
12	11,6	18	14	7	27	H.23010.0120
14	13,6	22	16	8	50	H.23010.0140
16	15,6	25	18	9	70	H.23010.0160
18	17,6	28	20	10	95	H.23010.0180
20	19,6	32	24	12	150	H.23010.0200
22	21,6	35	28	14	210	H.23010.0220
24	23,6	40	32	16	300	H.23010.0240
28	27,6	44	36	18	430	H.23010.0280
32	31,5	50	40	20	580	H.23010.0320
36	35,5	54	44	22	800	H.23010.0360
42	41,5	65	52	26	1250	H.23010.0420
48	47,5	75	60	30	1900	H.23010.0480
54	53,4	85	70	34	2600	H.23010.0540

MATIERE : INOX 1.4305

DIN 650 rainure	a	e	h	k	poids (g)	Ref.
8	7,6	13	10	6	10	H.23010.0720
10	9,6	15	12	6	16	H.23010.0730
12	11,6	18	14	7	27	H.23010.0740
14	13,6	22	16	8	50	H.23010.0750
16	15,6	25	18	9	70	H.23010.0760
18	17,6	28	20	10	95	H.23010.0780

ECROU EN Té LONG DIN 508.L

H.23020.0

MATIERE : acier traité.
EXECUTION : qualité 10 - noir, l = 2 x e.



Ød	DIN 650 rainure	a	e	l	h	k	poids (g)	Ref.
M5	6	5,6	10	20	8	4	8	H.23020.0060
M6	8	7,6	13	26	10	6	14	H.23020.0080
M8	10	9,6	15	30	12	6	30	H.23020.0100
M10	12	11,6	18	36	14	7	50	H.23020.0120
M12	14	13,6	22	44	16	8	82	H.23020.0140
M14	16	15,6	25	50	18	9	120	H.23020.0160
M16	18	17,6	28	56	20	10	170	H.23020.0180
M18	20	19,6	32	64	24	12	260	H.23020.0200
M20	22	21,6	35	70	28	14	360	H.23020.0220
M24	28	27,6	44	88	36	18	730	H.23020.0280
M30	36	35,5	54	108	44	22	1390	H.23020.0360

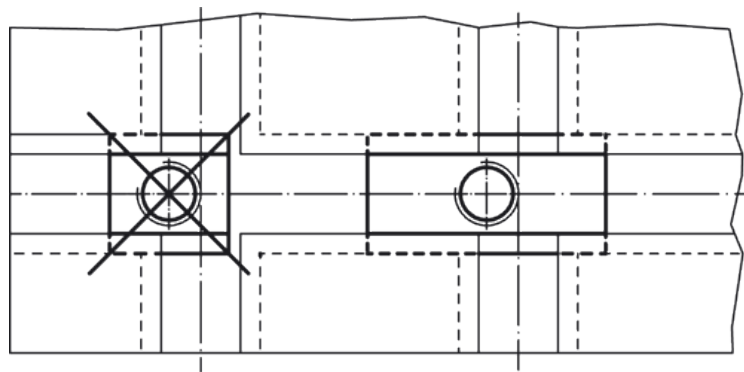
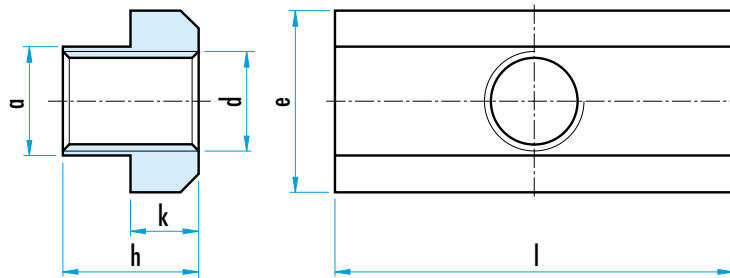

ECROU EN T  EN LOSANGE

H.23020.0

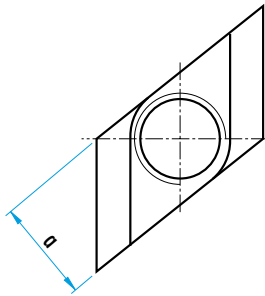
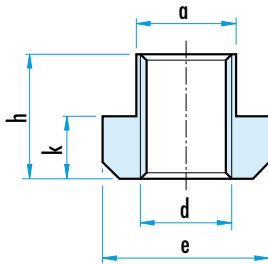

MATIERE : acier trait .

EXECUTION : qualit  10 - noir.

REMARQUE : de par sa forme cet  crou peut  tre introduit directement en toute position de la rainure.

Sur demande : • en aluminium, avec ou sans taraudage,

•  crou avec tige filet e monobloc : M20 x 22 x 80 / 125 / 200

M24 x 28 x 100 / 125 / 250.



Ø d	DIN 650 rainure	a	e	h	k	poids (g)	Ref.
M5	6	5,9	10	8	4	2	H.23020.0560
M6	8	7,6	13	10	6	5	H.23020.0580
M8	10	9,6	15	12	6	9	H.23020.0600
M10	12	11,6	18	14	7	11	H.23020.0620
M12	14	13,6	22	16	8	20	H.23020.0640
M14	16	15,6	25	18	9	30	H.23020.0660
M16	18	17,6	28	20	10	45	H.23020.0680
M18	20	19,6	32	24	12	70	H.23020.0700
M20	22	21,6	35	28	14	95	H.23020.0720
M24	28	27,6	44	36	18	215	H.23020.0780
M30	36	35,5	54	44	22	430	H.23020.0860
M36	42	41,5	65	52	26	690	H.23020.0920

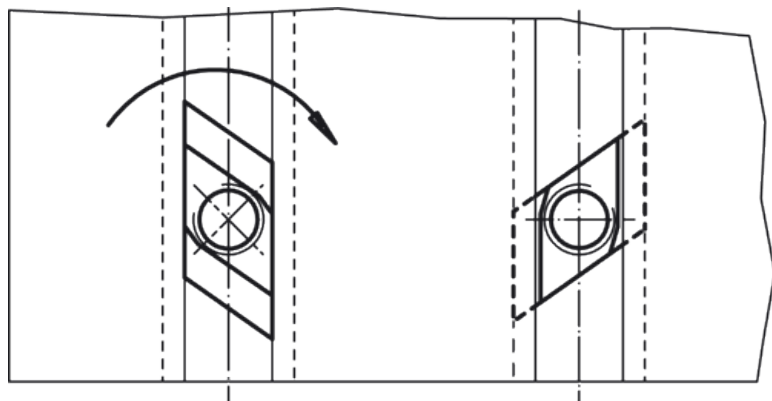

ECROU EN T^e EN LOSANGE SANS TARAUDAGE

H.23020.0561

MATIERE :
Acier traité qualité 10, noirci.

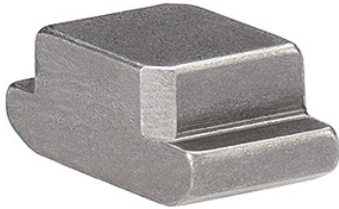

Largeur rainure	a	e	h	k	Ref.
6	5,7	10	8	4	H.23020.0561
8	7,6	13	10	6	H.23020.0581
10	9,6	15	12	6	H.23020.0601
12	11,6	18	14	7	H.23020.0621
14	13,6	22	16	8	H.23020.0641
16	15,6	25	18	9	H.23020.0661
18	17,6	28	20	10	H.23020.0681
20	19,6	32	24	12	H.23020.0701
22	21,6	35	28	14	H.23020.0721
28	27,6	44	36	18	H.23020.0781
36	35,5	54	44	22	H.23020.0861

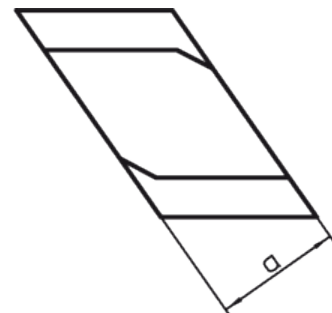
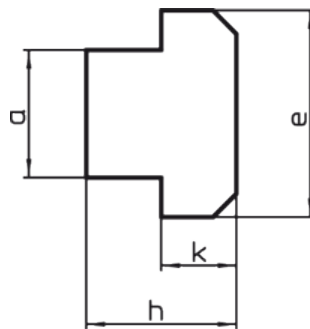

ECROU EN Té - ANTI DERAPANT

□ DIN 508

H.23010

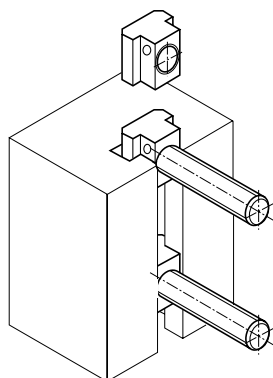

MATIERE : acier traité - qualité 10, noirci, élément ressort en acier à roulement trempé.
REMARQUE : l'élément ressort empêche le glissement de l'écrou en Té aussi bien en position horizontale que verticale.

d	DIN 650 rainure	a	e	h	k	s	poids (g)	Ref.
M8	10	9,6	15	12	6	0,65	14	H.23010.0811
M10	12	11,6	18	14	7	0,80	22	H.23010.0813
M12	14	13,6	22	16	8	0,90	34	H.23010.0815
M16	18	17,6	28	20	10	1,00	68	H.23010.0819
M20	22	21,6	35	28	14	1,60	155	H.23010.0823

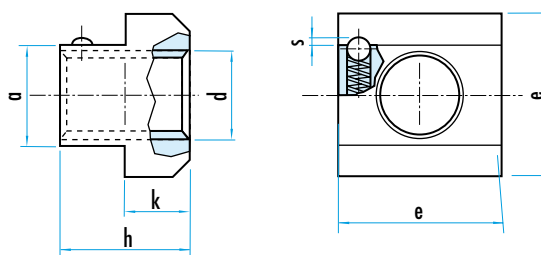

ECROU EN Té A RESSORT

□ DIN 508

KOP.39 - D508F.

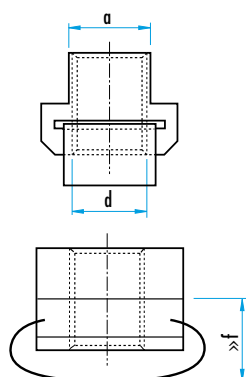
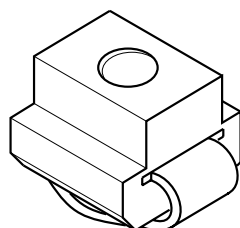

MATIERE : acier bichromaté = Ref. KOP.39...,
 acier noirci, qualité 10 = Ref. D508F..

EXECUTION : avec lamelle flexible en INOX.

REMARQUE : Ne tombe pas automatiquement dans le fond de la rainure. Tient en place, même dans des rainures verticales.

A une fonction de nettoyage de la rainure.

Voir cotes sur page 27.

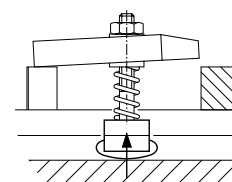

largeur rainure (a)	filet (d)	Ref.	
		acier bichromaté	acier qualité 10
12	M8	KOP.39.025	D508F.12.08
12	M10	-	D508F.12.10
14	M8	KOP.39.030	D508F.14.08
14	M10	KOP.39.050	D508F.14.10
14	M12	-	D508F.14.12
16	M8	KOP.39.035	D508F.16.08
16	M10	KOP.39.055	D508F.16.10
16	M12	KOP.39.080	-
18	M10	KOP.39.060	D508F.18.10
18	M12	KOP.39.085	-
18	M16	-	D508F.18.16
22	M10	KOP.39.070	-
22	M12	KOP.39.095	-
22	M20	-	D508F.22.20