

## RONDELLE PLATE RENFORCEE DIN 6340

D6340.

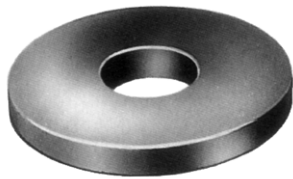

**MATIERE** : acier traité.

**EXECUTION** : découpée, planée et trempée.

**REMARQUE** : les dimensions avec un (\*) ne font pas partie de la norme DIN.

Utilisé lorsque la face réceptrice est perpendiculaire à l'axe de la vis.

Sur demande :

- dimensions "inch" : Réf. WWN.400,
- aluminium.

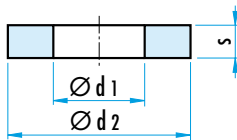
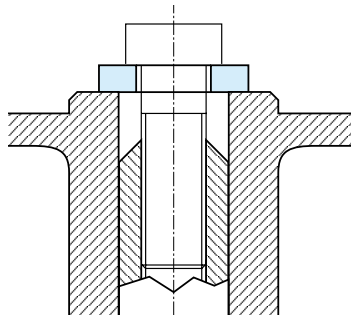

Ø d1	Ø d2	s	pour vis	Ref.
6,4	17	3	M6	D6340.06
8,4	23	4	M8	D6340.08
10,5	28	4	M10	D6340.10
13	35	5	M12	D6340.13
15(*)	40	5	M14	D6340.15
17	45	6	M16	D6340.17
19(*)	45	6	M18	D6340.19
21	50	6	M20	D6340.21
23(*)	50	8	M22	D6340.23
28(*)	68	10	M27	D6340.28
25	60	8	M24	D6340.25
31	68	10	M30	D6340.31
38(*)	80	12	M36	D6340.38
44(*)	100	15	M42	D6340.44
50(*)	110	17	M48	D6340.50

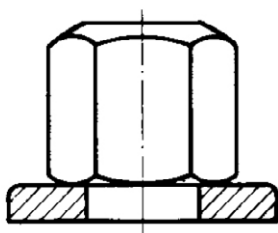

## RONDELLE PLATE DE PRECISION

H.23060



**MATIERE :**  
Acier traité, bruni ou INOX 1.4305.

d1	d2	s	pour vis	poids (g)	Ref.	
					acier	INOX
5,3	13	3	M5	2,5	H.23060.0105	H.23060.0155
6,4	17	3	M6	4,5	H.23060.0106	H.23060.0156
8,4	24	4	M8	12	H.23060.0108	H.23060.0158
10,5	30	4	M10	19	H.23060.0110	H.23060.0160
13	36	5	M12	34	H.23060.0113	H.23060.0163
17	45	5	M16	53	H.23060.0117	H.23060.0167

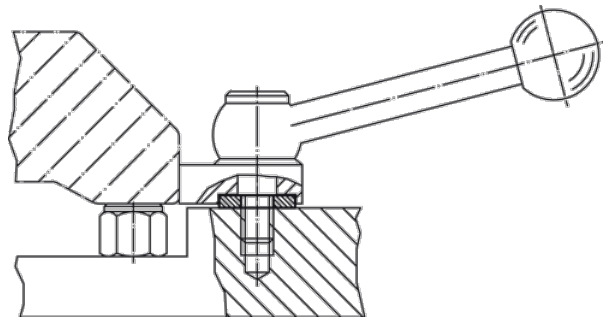
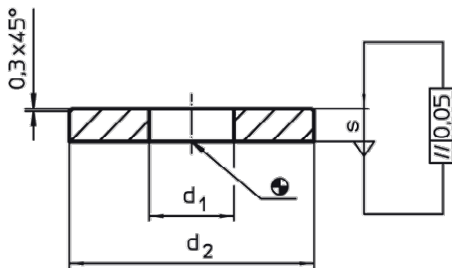

## RONDELLE PLATE EN INOX

WWN.802

MATIERE ET EXECUTION : INOX 316.

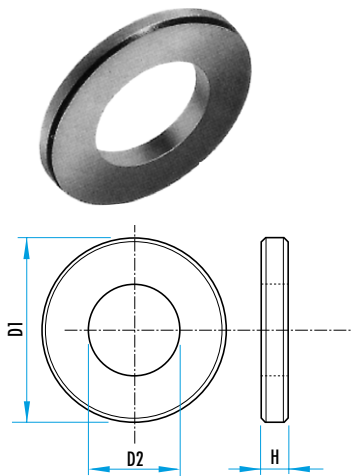

D2	D1	H	pour vis	Réf.
6,5	16	2,5	M6	WWN.802.206
8,5	20	2,5	M8	WWN.802.208
10,5	25	3	M10	WWN.802.210
12,5	30	3,5	M12	WWN.802.212
16,5	35	4	M16	WWN.802.216

## RONDELLE PLATE DE PRECISION

WWN.400

MATIERE ET EXECUTION : en acier cémenté, finement usiné.  
Sur demande : Dimensions "inch".

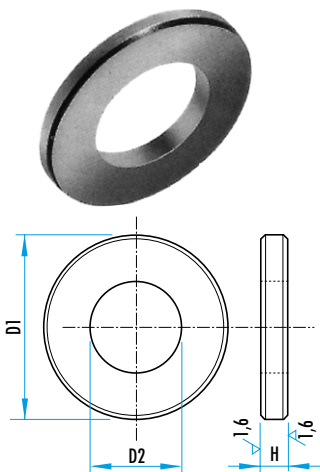

D2	D1	H	pour vis	Réf.
4,5	10	1,5	M4	WWN.400.2004
5,5	12	2,5	M5	WWN.400.2005
6,5	16	2,5	M6	WWN.400.201
8,5	20	3	M8	WWN.400.202
10,5	22	3	M10	WWN.400.203
10,5	25	5	M10	WWN.400.204
13,3	28	3	M12	WWN.400.205
15,2	28	3	M14	WWN.400.206
16,7	32	3	M16	WWN.400.207
16,7	38	6,5	M16	WWN.400.208
20,7	38	4	M20	WWN.400.209
26,7	50	5	M24	WWN.400.211