

## VIS A OEILLET USINEE DIN 444.B (tol. 0/+ ) - ISO 7379

**D444B**

### MATIERE ET EXECUTION :

Usinée pour applications mécaniques.  
 $\varnothing$  du corps plus petit que le  $\varnothing$  du filet roulé.

### En acier :

Ref. H.22980.02... / 03... : acier 8.8, noirci

Ref. D444B...G / K : acier 5.8, noirci

### En INOX :

Ref. H.22980.04... / 05... : INOX 1.4301 – AISI 304

résistance à la traction : min 50 daN / mm<sup>2</sup>

Ref. D444B...GR / KR : INOX 1.4305 – AISI 303

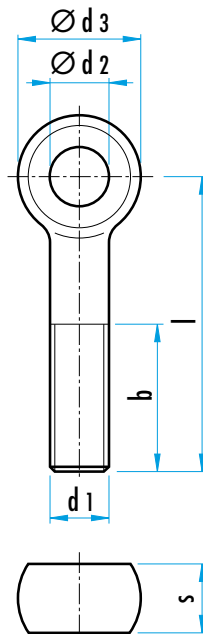

d1	l	b	d2 H9	d3	s	Ref.	
						acier	INOX
M5	25	16	5	12	6	H.22980.0202	H.22980.0402
	30	16	5	12	6	H.22980.0203	H.22980.0403
	35	16	5	12	6	H.22980.0204	H.22980.0404
	40	16	5	12	6	H.22980.0205	H.22980.0405
	50	16	5	10	6	D444B.05.050.K	D444B.05.050.KR
	75	16	5	10	6	D444B.05.075.K	-
M6	30	18	6	14	7	H.22980.0212	H.22980.0412
	40	18	6	14	7	H.22980.0214	H.22980.0414
	50	18	6	14	7	H.22980.0216	H.22980.0416
	50	32	6	14	7	D444B.06.050.G	D444B.06.050.GR
	60	18	6	14	7	H.22980.0218	H.22980.0418
	75	32	6	14	7	D444B.06.075.G	D444B.06.075.GR
	80	18	6	14	7	H.22980.0222	H.22980.0422
M8	40	22	8	18	9	H.22980.0232	H.22980.0432
	50	22	8	18	9	H.22980.0234	H.22980.0434
	50	32	8	18	9	D444B.08.050.G	D444B.08.050.GR
	60	22	8	18	9	H.22980.0236	H.22980.0436
	75	32	8	18	9	D444B.08.075.G	D444B.08.075.GR
	80	22	8	18	9	H.22980.0240	H.22980.0440
	100	22	8	18	9	H.22980.0244	H.22980.0444
M10	50	26	10	20	12	H.22980.0252	H.22980.0452
	50	40	10	20	12	D444B.10.050.G	D444B.10.050.GR
	60	26	10	20	12	H.22980.0254	H.22980.0454
	75	26	10	20	12	H.22980.0257	H.22980.0457
	75	40	10	20	12	D444B.10.075.G	D444B.10.075.GR
	100	26	10	20	12	H.22980.0262	H.22980.0462
	100	40	10	20	12	D444B.10.100.G	D444B.10.100.GR

## VIS A OEILLET USINEE DIN 444.B (tol. 0/+ ) - ISO 7379

**D444B**

### MATIERE ET EXECUTION :

Usinée pour applications mécaniques.  
 $\varnothing$  du corps plus petit que le  $\varnothing$  du filet roulé.

#### En acier :

Ref. H.22980.02... / 03... : acier 8.8, noirci

Ref. D444B...G / K : acier 5.8, noirci

#### En INOX :

Ref. H.22980.04... / 05... : INOX 1.4301 – AISI 304

résistance à la traction : min 50 daN / mm<sup>2</sup>

Ref. D444B...GR / KR : INOX 1.4305 – AISI 303

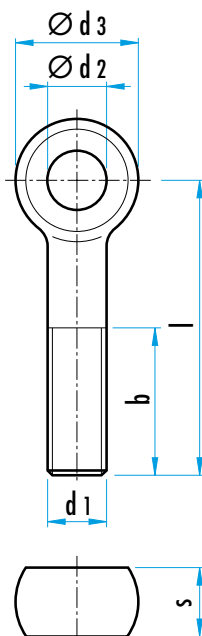

d1	l	b	d2 H9	d3	s	Ref.	
						acier	INOX
M12	50	30	12	25	14	H.22980.0272	H.22980.0472
	60	30	12	25	14	H.22980.0274	H.22980.0474
	75	40	12	25	14	D444B.12.075.G	D444B.12.075.GR
	80	30	12	25	14	H.22980.0278	H.22980.0478
	100	30	12	25	14	H.22980.0282	H.22980.0482
	100	40	12	25	14	D444B.12.100.G	D444B.12.100.GR
	120	30	12	25	14	H.22980.0286	H.22980.0486
	130	40	12	25	14	D444B.12.130.G	D444B.12.130.GR
M14	75	36	14	28	16	D444B.14.075.K	D444B.14.075.KR
	130	36	14	28	16	D444B.14.130.K	D444B.14.130.KR
M16	60	38	16	32	17	H.22980.0292	H.22980.0492
	75	50	16	32	17	D444B.16.075.G	D444B.16.075.GR
	80	38	16	32	17	H.22980.0294	H.22980.0494
	100	38	16	32	17	H.22980.0298	H.22980.0498
	100	50	16	32	17	D444B.16.100.G	D444B.16.100.GR
	120	38	16	32	17	H.22980.0302	H.22980.0502
	130	50	16	32	17	D444B.16.130.G	D444B.16.130.GR
	150	44	16	32	17	H.22980.0308	H.22980.0508
M20	100	46	18	40	22	H.22980.0312	H.22980.0512
	100	63	18	40	22	D444B.20.100.G	-
	120	46	18	40	22	H.22980.0316	H.22980.0516
	130	63	18	40	22	D444B.20.130.G	-
	140	52	18	40	22	D444B.20.140.K	D444B.20.140.KR
	160	52	18	40	22	H.22980.0324	H.22980.0524
	160	63	18	40	22	D444B.20.160.G	-
	200	52	18	40	22	H.22980.0332	H.22980.0532
M24	100	54	22	45	25	H.22980.0342	H.22980.0542
	120	54	22	45	25	H.22980.0346	H.22980.0546
	160	60	22	45	25	H.22980.0354	H.22980.0554
	200	60	22	45	25	H.22980.0362	H.22980.0562

## VIS A ŒILLET DE PRECISION - DIN 444.B (tol. 0/+)

H.22980



### MATIERE ET EXECUTION :

Acier traité 8.8, bruni.  
Exécution de précision.  
Le filetage est roulé.  
Les surfaces de cote "s" sont usinées.  
Tolérance  $\varnothing d2 = H7$  à la place de H9.

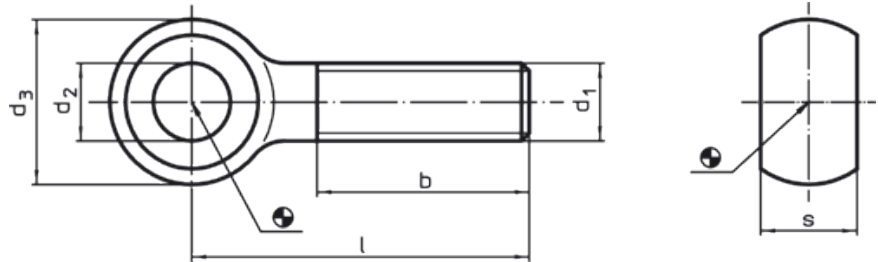

d1	l	d2 h7	d3	b	s-0,2	Ref.
M8	40	8	18	22	9	H.22980.0081
M8	60	8	18	22	9	H.22980.0084
M10	50	10	20	26	12	H.22980.0103
M10	75	10	20	26	12	H.22980.0106
M10	100	10	20	26	12	H.22980.0108
M12	60	12	25	30	14	H.22980.0122
M12	80	12	25	30	14	H.22980.0125
M12	120	12	25	30	14	H.22980.0128
M16	80	16	32	38	17	H.22980.0163
M16	150	16	32	44	17	H.22980.0168

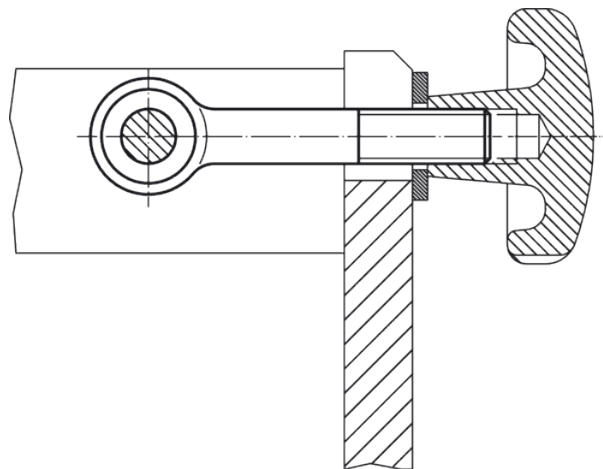

## VIS A OEILLET USINEE DIN 444.B (tol. +/-) - ISO 7379

WWN.611 / 810



**MATIERE ET EXECUTION :**  
usinée pour application mécanique,  
Ø du corps = Ø du filet roulé.

**Ref. WWN.611 :** acier noirci,  
**Ref. WWN.810 :** INOX 1.4301,  
tol. d2 : +0,025/+0,13

Sur demande : dimensions en pouce.  
Modèle plus léger avec cotes d2 et "s" plus petits.

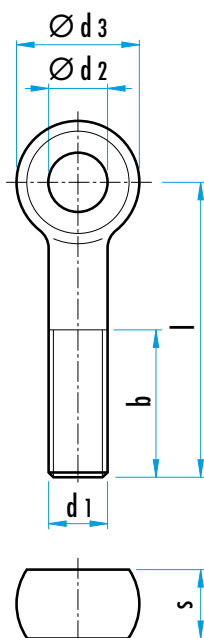

d1	l	b	d2 <sup>(+0,025)</sup> (+0,13)	d3	s (-0,13)	Art	
						acier	INOX
M4	30	20	4	10	5	WWN.611.251	-
M5	40	25	5	12	6	WWN.611.252	WWN.810.205.040
M5	60	30	5	12	6	WWN.611.253	WWN.810.205.060
M6	40	25	6	14	7	WWN.611.254	WWN.810.206.040
M6	50	30	6	14	7	WWN.611.255	WWN.810.206.050
M6	75	40	6	14	7	WWN.611.256	-
M8	40	25	8	18	9	WWN.611.257	-
M8	50	30	8	18	9	WWN.611.258	WWN.810.208.050
M8	75	40	8	18	9	WWN.611.259	WWN.810.208.075
M10	50	30	10	20	12	WWN.611.260	WWN.810.210.050
M10	75	40	10	20	12	WWN.611.261	WWN.810.210.075
M10	100	40	10	20	12	WWN.611.262	WWN.810.210.100
M12	75	50	12	25	14	WWN.611.263	WWN.810.212.075
M12	100	60	12	25	14	WWN.611.264	WWN.810.212.100
M12	125	60	12	25	14	WWN.611.265	WWN.810.212.125
M12	150	60	12	25	14	WWN.611.266	-
M14	100	60	14	28	16	WWN.611.267	-
M14	125	60	14	28	16	WWN.611.268	-
M16	100	60	16	32	17	-	WWN.810.216.100
M16	125	60	16	32	17	WWN.611.269	WWN.810.216.125
M16	150	75	16	32	17	WWN.611.270	WWN.810.216.150
M20	150	75	18	40	22	WWN.611.271	-
M20	175	100	18	40	22	WWN.611.272	-
M24	150	75	22	48	25	WWN.611.273	-
M24	200	100	22	48	25	WWN.611.274	-

## VIS A OEILLET BRUTE DIN 444.B - ISO 7379

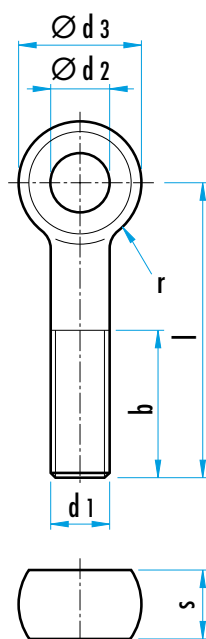

exécution spéciale sur demande

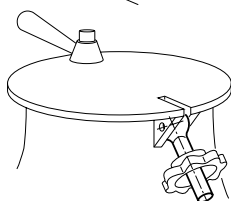
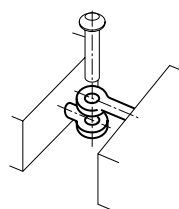
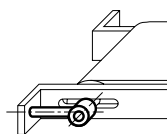
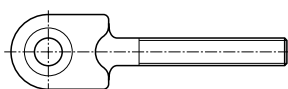
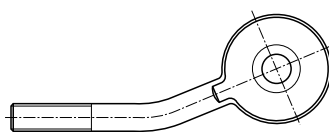

**MATIERE** : acier 4.6.

Sur demande : zingué ou INOX ou autres qualités d'acier : 5.6 - 8.8 - 10.9.

**EXECUTION** : forgée, brute.

**REMARQUE** : Il s'agit ici de la DIN 444 officielle.

Ces vis à oeillet sont produites en grandes quantités par les fabricants et leur prix est donc très intéressant à partir de 100 à 200 pièces en acier 4.6 ou 5.6.



d1 (mm)	M5	M6	M8	M10	M12	M16	M20	M24	M27	M30	M33	M36	M39
30	•												
35	•	•											
40	•	•	•										
45	•	•	•	•									
50	•	•	•	•	•								
55	•	•	•	•	•								
60	•	•	•	•	•								
65	•	•	•	•	•								
70	•	•	•	•	•	•							
75	•	•	•	•	•	•							
80	•	•	•	•	•	•							
90		•	•	•	•	•							
100			•	•	•	•	•	•					
110			•	•	•	•	•	•					
120			•	•	•	•	•	•	•				
130			•	•	•	•	•	•	•				
140			•	•	•	•	•	•	•				
150			•	•	•	•	•	•	•	•	•		
160					•	•	•	•	•	•	•	•	•
180					•	•	•	•	•	•	•	•	•
200					•	•	•	•	•	•	•	•	•
220					•	•	•	•	•	•	•	•	•
240					•	•	•	•	•	•	•	•	•
260					•	•	•	•	•	•	•	•	•
280									•	•	•	•	•
300									•	•	•	•	•

d1 mm	M5	M6	M8	M10	M12	M16	M20	M24	M27	M30	M33	M36	M39
Ø d2	5	6	8	10	12	16	18	22	24/25	27/28	30	32/33	35/36
Ø d3 max	12	14	18	20	25	32	40	45	50	55	60	65	70
Ø d3 min	11,57	13,57	17,57	19,48	24,48	31,38	39,38	44,38	49,38	54,26	59,26	64,26	69,26
b(*)	16	18	22	26	30	38	46	54	60	66	-	-	-
b1/b2(*)	-/-	-/-	28/-	32/-	36/49	44/57	52/65	60/73	66/79	72/85	-	-	-
s max	6	7	9	12	14	17	22	25	27	30	34	38	41
s min	5,88	6,85	8,85	11,82	13,82	16,82	21,79	24,79	26,79	29,79	33,75	37,75	40,75
l	voir tableau												

(\*) b : pour l <sup>2</sup> 125 mm

b1 : pour 125 <sup>2</sup> l <sup>2</sup> 200 mm

b2 : pour l > 200 mm