

PATIN ARTICULE AVEC GOUJON

H.22590

MATIERE ET EXECUTION :

Ref. H.22590.04... : patin, rotule et goujon en acier bruni.

Ref. H.22590.05... : patin en thermoplast (POM) blanc, rotule et axe en INOX 1.4305.

Ref. H.22590.06... : patin, rotule et axe en INOX 1.4305.

REMARQUE :

Utilisé comme pied ou support.

Température d'utilisation : max. 80° pour l'exécution «thermoplast»



d1	l1	d2	l2	~ h1	h2	SW	Charge statique max. (kN)		Poids (g)	Ref.	
							acier	INOX		acier	INOX
M6	60	20	57,0	14	2,5	10	10	8	29	H.22590.0410	H.22590.0610
M8	80	25	76,0	18	4,0	13	18	14	66	H.22590.0422	H.22590.0622
M10	100	32	95,5	22	5,0	17	20	16	133	H.22590.0438	H.22590.0638
M10	150	32	145,5	22	5,0	17	20	16	159	H.22590.0442	H.22590.0642
M12	100	40	94,5	26	6,0	19	35	28	211	H.22590.0452	H.22590.0652
M12	150	40	144,5	26	6,0	19	35	28	247	H.22590.0456	H.22590.0656
M16	100	50	94,0	32	7,0	24	45	36	407	H.22590.0468	H.22590.0668
M16	200	50	194,0	32	7,0	24	45	36	540	H.22590.0472	H.22590.0672
M20	100	60	92,5	42	8,0	30	55	44	722	H.22590.0482	H.22590.0682
M20	200	60	192,5	42	8,0	30	55	44	924	H.22590.0488	H.22590.0688
M24	100	60	91,0	45	9,5	36	65	52	935	H.22590.0495	H.22590.0695
M24	200	60	191,0	45	9,5	36	65	52	1231	H.22590.0498	H.22590.0698

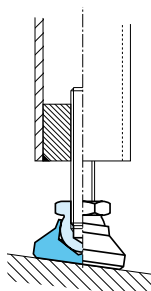
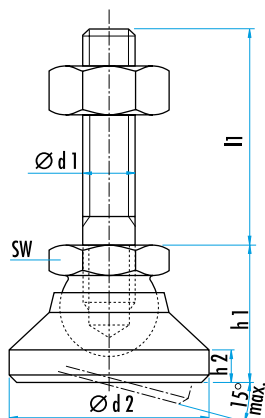

d1	l1	d2	l2	~ h1	h2	SW	Charge statique max. (kN)	Poids (g)	Ref. POM / INOX
M6	60	20	57,0	14	2,5	10	4	20	H.22590.0510
M8	80	25	76,0	18	4,0	13	7	46	H.22590.0522
M10	100	32	95,5	22	5,0	17	10	92	H.22590.0538
M10	150	32	145,5	22	5,0	17	10	118	H.22590.0542
M12	100	40	94,5	26	6,0	19	18	139	H.22590.0552
M12	150	40	144,5	26	6,0	19	18	173	H.22590.0556
M16	100	50	94,0	32	7,0	24	20	264	H.22590.0568
M16	200	50	194,0	32	7,0	24	20	393	H.22590.0572
M20	100	60	92,5	42	8,0	30	22	463	H.22590.0582
M20	200	60	192,5	42	8,0	30	22	664	H.22590.0588
M24	100	60	91,0	45	9,5	36	25	662	H.22590.0595
M24	200	60	191,0	45	9,5	36	25	960	H.22590.0598

PATIN ARTICULE EN INOX AVEC TROUS DE FIXATION

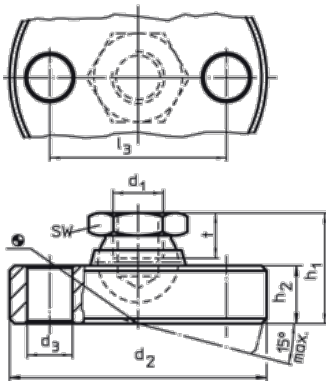
H.22590

MATIERE ET EXECUTION :

Tous les composants en INOX 1.4305.

REMARQUE :

S'utilise comme pied ou support.

Patin muni de 2 alésages de fixation.



d1	l1	d2 -0,5	d3	l2	l3	h1	h2	t	SW	Charge statique max. (kN)	Poids (g)	Ref.
M6	-	45	6,6	-	32	14	6,5	5	10	8	79	H.22590.0706
M8	-	50	6,6	-	38	18	8,5	7	13	14	130	H.22590.0708
M10	-	60	9	-	44	22	11,5	9	17	16	250	H.22590.0710
M12	-	65	9	-	48	26	12,5	11	19	28	326	H.22590.0712
M16	-	70	9	-	54	32	13,5	13,5	24	36	427	H.22590.0716
M20	-	80	9	-	64	42	16,5	17	30	44	718	H.22590.0720
M24	-	100	11	-	78	45	20,5	19	36	52	1304	H.22590.0724

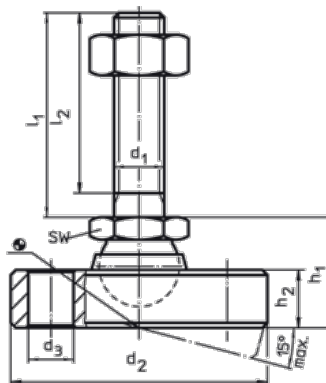

d1	l1	d2 -0,5	d3	l2	l3	h1	h2	t	SW	Charge statique max. (kN)	Poids (g)	Ref.
M6	60	45	6,6	57	32	14	6,5	-	10	8	93	H.22590.0810
M8	80	50	6,6	76	38	18	8,5	-	13	14	163	H.22590.0822
M10	100	60	9	95,5	44	22	11,5	-	17	16	318	H.22590.0838
M10	150	60	9	145,5	44	22	11,5	-	17	16	341	H.22590.0842
M12	100	65	9	94,5	48	26	12,5	-	19	28	423	H.22590.0852
M12	150	65	9	144,5	48	26	12,5	-	19	28	459	H.22590.0856
M16	100	70	9	94	54	32	13,5	-	24	36	615	H.22590.0868
M16	200	70	9	194	54	32	13,5	-	24	36	746	H.22590.0872
M20	100	80	9	92,5	64	42	16,5	-	30	44	1029	H.22590.0882
M20	200	80	9	192,5	64	42	16,5	-	30	44	1231	H.22590.0888
M24	100	100	11	91	78	45	20,5	-	36	52	1775	H.22590.0895
M24	200	100	11	191	78	45	20,5	-	36	52	2075	H.22590.0898

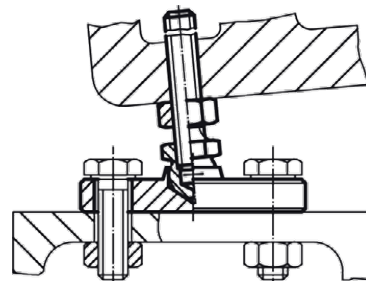

PIED DE REGLAGE ARTICULE

WWN.673 / 818

MATIERE :

Ref. WWN.673... : en acier nickelé,

Ref. WWN.818... : en INOX AISI 316.

EXECUTION :

Ref. WWN.673A... : pied avec dégagement central,

Ref. WWN.673P... : pied avec capuchon en plastique.

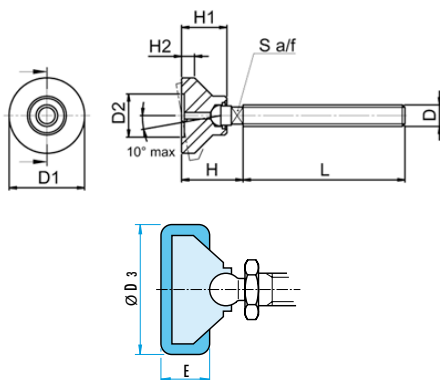
EN ACIER NICKELE : Ref. WWN.673...

D	L	D1	D2	D3	H	H1	H2	E	S	capacité (daN)	Ref.
M8	100	30	15	38	24	17	5	14	7	175	WWN.673X.08.100
M10	75	35	20	43	27	20	6	15	8	300	WWN.673X.10.075
M10	150	35	20	43	27	20	6	15	8	300	WWN.673X.10.150
M12	75	50	25	60	35	26	8	19	9	500	WWN.673X.12.075
M12	150	50	25	60	35	26	8	19	9	500	WWN.673X.12.150
M16	100	75	35	83	41	31	10	19	13	900	WWN.673X.16.100
M16	200	75	35	83	41	31	10	19	13	900	WWN.673X.16.200
M20	100	100	50	108	51	36	12	24	17	1500	WWN.673X.20.100
M20	200	100	50	108	51	36	12	24	17	1500	WWN.673X.20.200
M24	200	120	60	128	60	39	15	28	17	2000	WWN.673X.24.200
M24	400	120	60	128	60	39	15	28	17	2000	WWN.673X.24.400

POUR LA COMMANDE :

sans capuchon : D = M10, L = 150 = Ref. WWN.673A.10.150

avec capuchon : D = M24, L = 400 = Ref. WWN.673P.24.400

EN INOX : Ref. WWN.818...

D	D1	L	L1	L2	L3	S	capacité (daN)	Ref.
M16	80	100	45	22	10	24	2.200	WWN.818.16.100
M16	80	150	45	22	10	24	2.200	WWN.818.16.150
M16	80	200	45	22	10	24	2.200	WWN.818.16.200
M20	80	100	50	22	10	30	2.200	WWN.818.20.100
M20	80	150	50	22	10	30	2.200	WWN.818.20.150
M20	80	200	50	22	10	30	2.200	WWN.818.20.200

