

BOUTON A TIRER EN ACIER OU INOX

H.24520...



MATIERE ET EXECUTION :

Tête avec moletage :

En acier = Ref. H.24520.0022 à 0029

En INOX = Ref. H.24520.0122 à 0129.

Tête lisse, sans moletage :

En acier = Ref. H.24520.0002 à 0009

En INOX = Ref. H.24520.0102 à 0109.

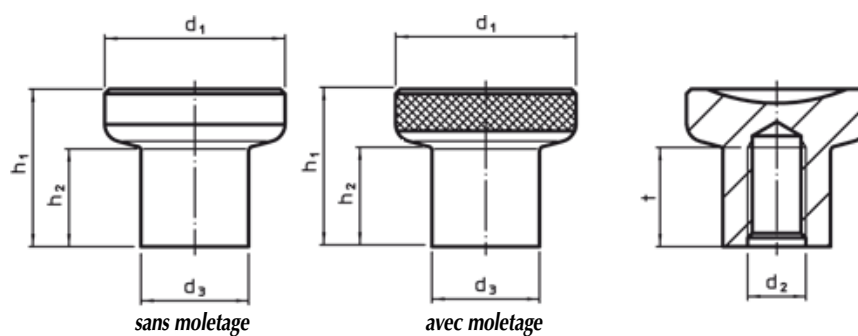

Ø d1	Ø d2	Ø d3	h1	h2	t min.	poids (g)	Ref. avec moletage		Ref. sans moletage	
							acier	INOX	acier	INOX
21	M4	12,5	18	10,5	10	26	H.24520.0022	H.24520.0122	H.24520.0002	H.24520.0102
21	M5	12,5	18	10,5	10	25	H.24520.0023	H.24520.0123	H.24520.0003	H.24520.0103
25	M6	14,5	22,5	14	12	40	H.24520.0025	H.24520.0125	H.24520.0005	H.24520.0105
25	M8	14,5	22,5	14	12	40	H.24520.0026	H.24520.0126	H.24520.0006	H.24520.0106
31	M8	18,5	27	17	15	75	H.24520.0028	H.24520.0128	H.24520.0008	H.24520.0108
31	M10	18,5	27	17	17	74	H.24520.0029	H.24520.0129	H.24520.0009	H.24520.0109

