

**RESSORTS A GAZ POUR OUTILLAGES  
FORCE RESSORT ÉLEVÉE "POWER LINE"**

Art. 2487.12.00170

2487.12.00170.

La force initiale du ressort à 180 bar est de 170 daN

N° de commande	Course max.	$l_{min}$	$l$
2487.12.00170.007	7	37	44
010	10	40	50
015	15	45	60
019	19	49	68
025	25	55	80
038	38	68	106
050	50	80	130
063	63	93	156
075	75	110	185
080	80	115	195
100	100	135	235
125	125	160	285

2487.12.00170.

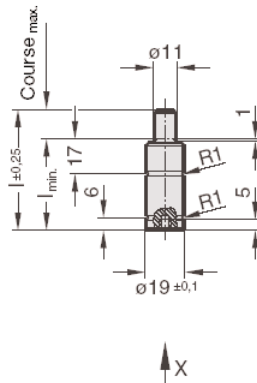

Vue selon X

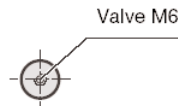

Indication :

Le ressort à gaz n'est pas réparable.

- Fluide de pression: Azote - N<sub>2</sub>
- Pression max. de remplissage en gaz: 180 bars
- Pression min. de remplissage en gaz: 25 bars
- Température de fonctionnement: 0°C à +80°C
- Augmentation de force en fonction de la température: ±0,3%/°C
- Nombre maximal recommandé de courses/minute: env. 40 à 100 (à 20 °C)
- Vitesse maximale du piston: 1,6 m/s

2487.12.00170.

Force initiale du ressort en fonction de la pression de remplissage

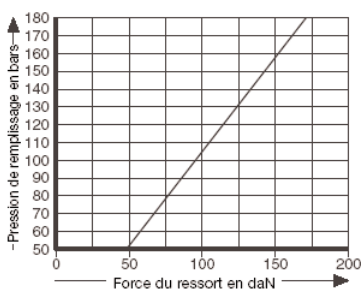

2487.12.00170.

Diagramme d'augmentation de la pression en fonction de la course

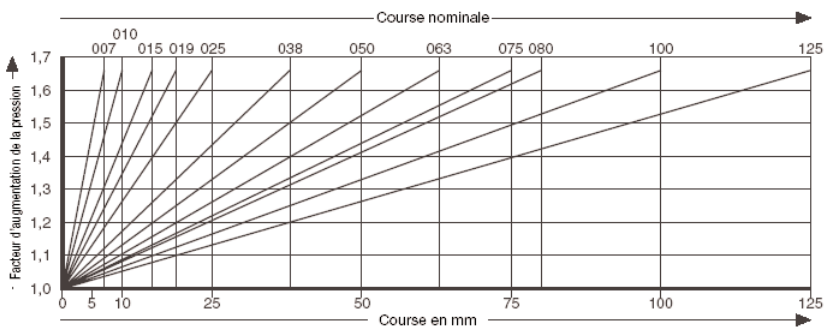

Le facteur d'augmentation de la pression concerne les compressions du volume du gaz en fonction de la course, sans paramètres d'influence!

**RESSORTS A GAZ POUR OUTILLAGES  
FORCE RESSORT ÉLEVÉE "POWER LINE"**

Art. 2487.12.00170

2480.051.00030

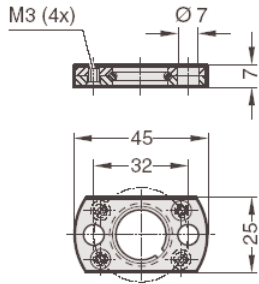

2480.051.00030

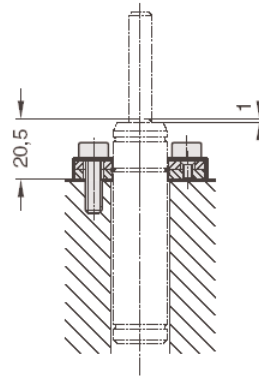

2480.052.00030

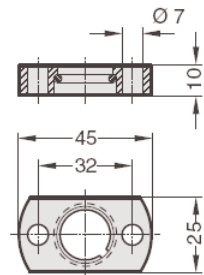

Exemples de montage:

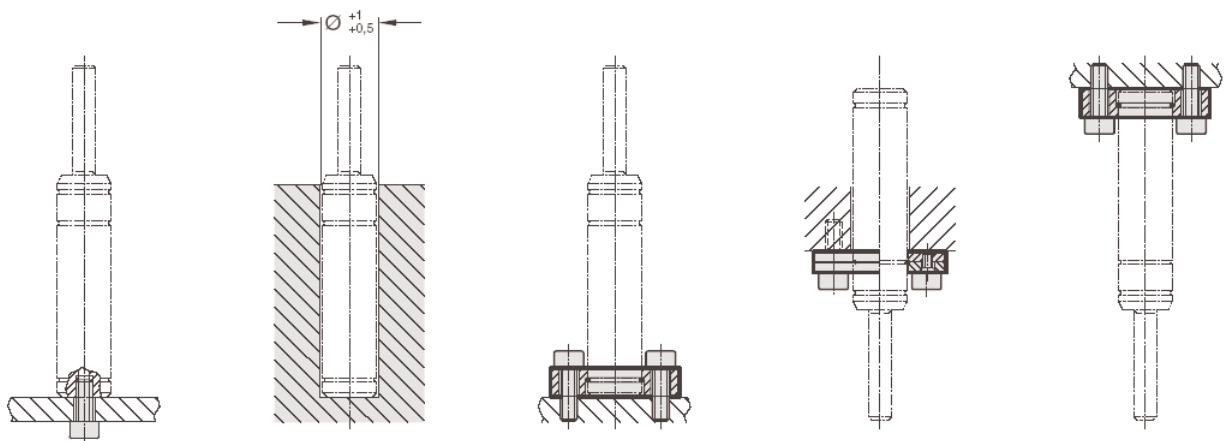

**RESSORTS A GAZ POUR OUTILLAGES  
FORCE RESSORT ÉLEVÉE "POWER LINE"**

Art. 2487.12.00350

2487.12.00350.

La force initiale du ressort à 180 bar est de 350 daN

N° de commande.	Course max.	l <sub>min</sub>	l
2487.12.00350. 010	10	40	50
013	13	43	56
016	16	46	62
019	19	49	68
025	25	55	80
032	32	62	94
038	38	68	106
050	50	80	130
063	63	93	156
075	75	105	180
080	80	110	190
100	100	130	230
125	125	155	280

2487.12.00350.

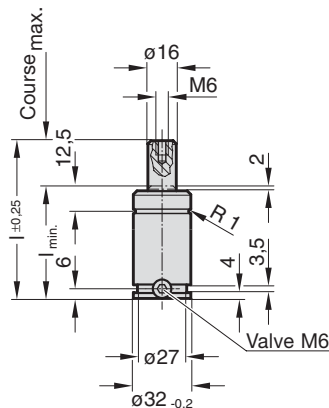

Vue selon X

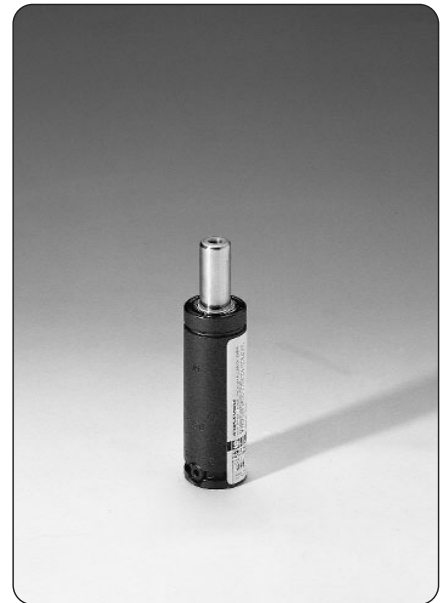
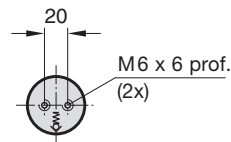

**Indication:**

N° de commande pour jeu de pièces détachées:  
2487.12.00350

Fluide de pression: Azote - N<sub>2</sub>  
 Pression max. de remplissage en gaz: 180 bars  
 Pression min. de remplissage en gaz: 25 bars  
 Température de fonctionnement: 0°C à +80°C  
 Augmentation de force en fonction de la température: ±0,3%/°C  
 Nombre maximal recommandé de courses/minute: env. 20 à 100 (à 20°C)  
 Vitesse maximale du piston: 0,8 m/s

2487.12.00350.

Force initiale du ressort en fonction de la pression de remplissage

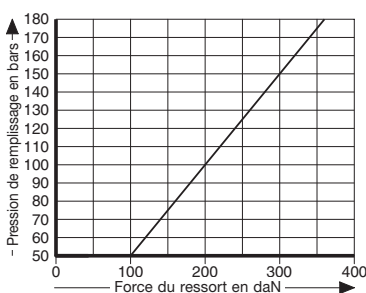

2487.12.00350.

Diagramme d'augmentation de la pression en fonction de la course

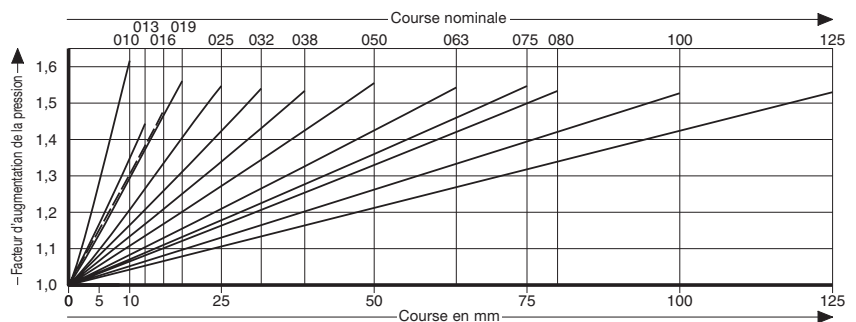

Le facteur d'augmentation de la pression concerne les compressions du volume du gaz en fonction de la course, sans paramètres d'influence!

**RESSORTS A GAZ POUR OUTILLAGES  
FORCE RESSORT ÉLEVÉE "POWER LINE"**

Art. 2487.12.00350

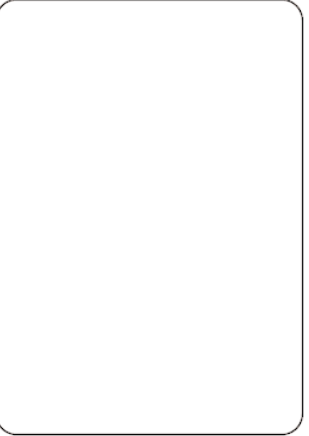
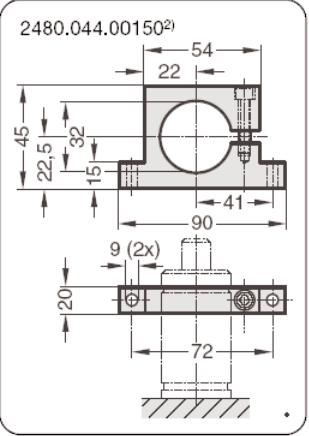
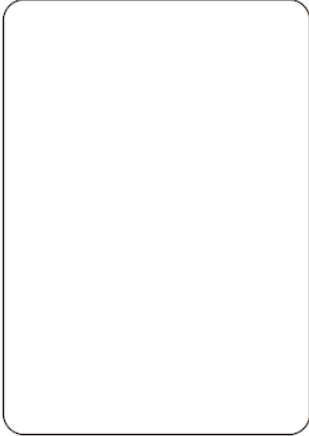
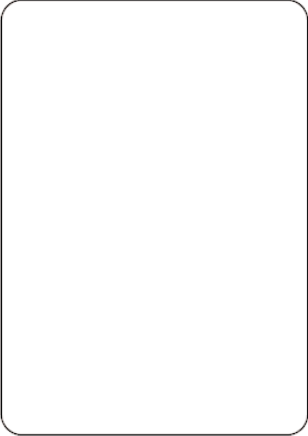
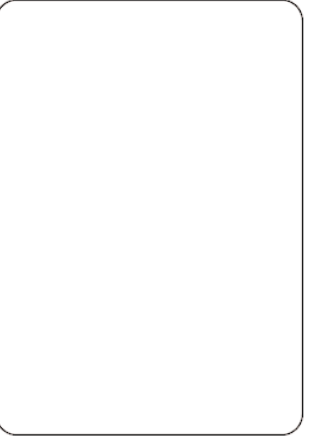
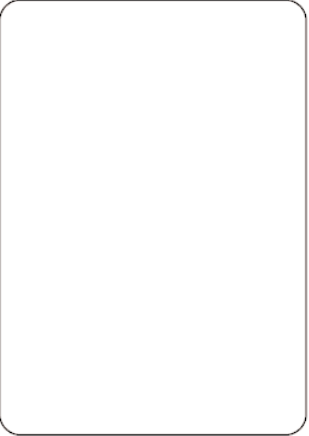
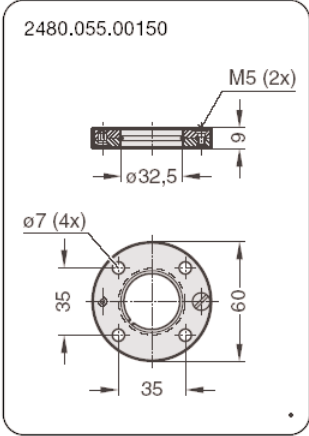
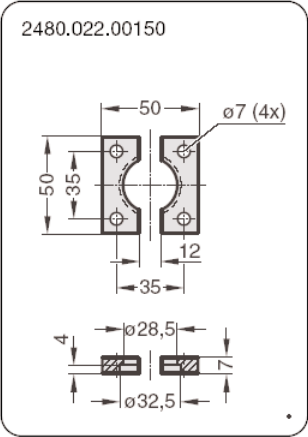
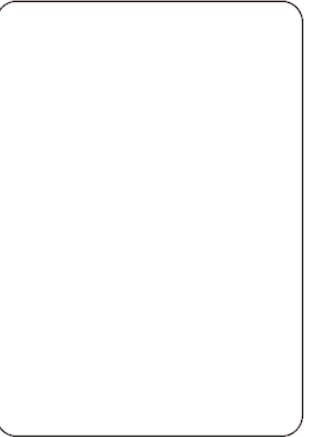
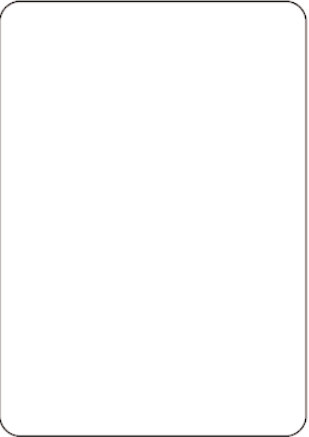
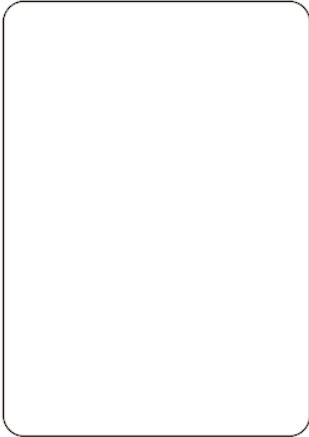

<sup>2)</sup> Attention:  
La force du ressort doit être supportée par la surface de butée!

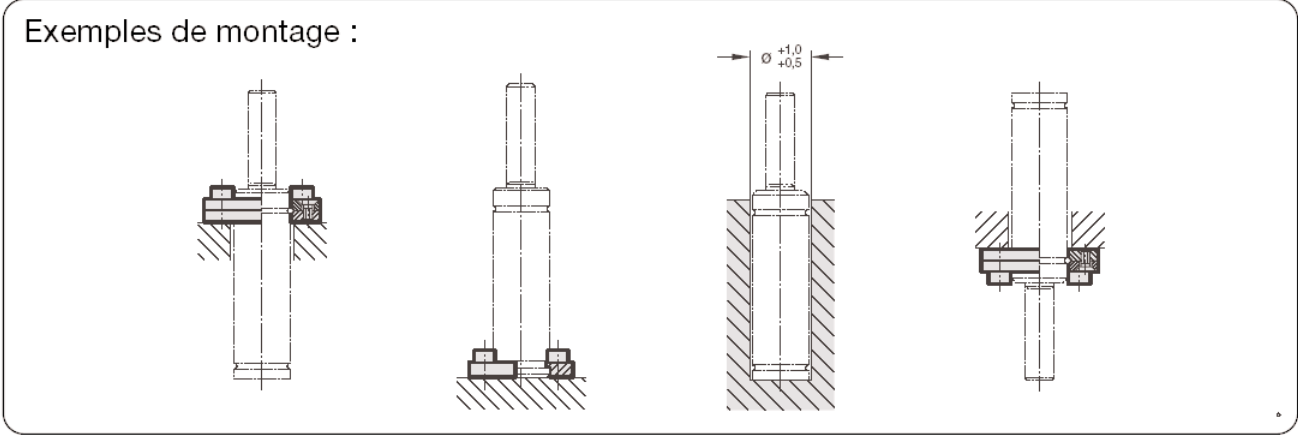

**RESSORTS A GAZ POUR OUTILLAGES  
FORCE RESSORT ÉLEVÉE "POWER LINE"**

Art. 2487.12.00500

2487.12.00500.

La force initiale du ressort à 150 bar est de 500 daN

N° de commande.	Course max.	l <sub>min</sub>	l
2487.12.00500. 010	10	40	50
013	13	43	56
016	16	46	62
019	19	49	68
025	25	55	80
032	32	62	94
038	38	68	106
050	50	80	130
063	63	93	156
075	75	105	180
080	80	110	190
100	100	130	230
125	125	155	280

2487.12.00500.

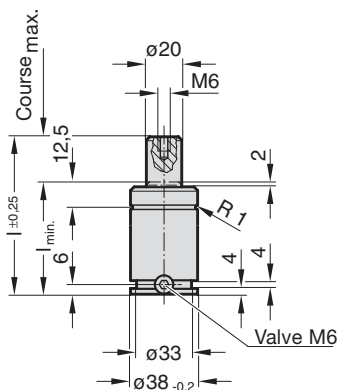

Vue selon X

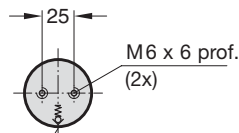

**Indication:**

N° de commande pour jeu de pièces détachées:  
2487.12.00500

Fluide de pression: Azote - N<sub>2</sub>  
 Pression max. de remplissage en gaz: 150 bars  
 Pression min. de remplissage en gaz: 25 bars  
 Température de fonctionnement: 0°C à +80°C  
 Augmentation de force en fonction de la température: ±0,3%/°C  
 Nombre maximal recommandé de courses/minute: env. 20 à 100 (à 20°C)  
 Vitesse maximale du piston: 0,8 m/s

2487.12.00500.

Force initiale du ressort en fonction de la pression de remplissage

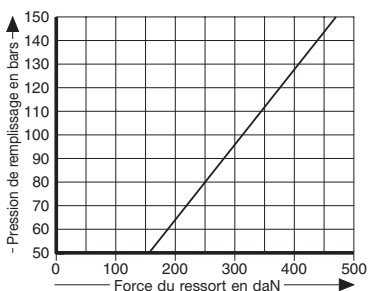

2487.12.00500.

Diagramme d'augmentation de la pression en fonction de la course

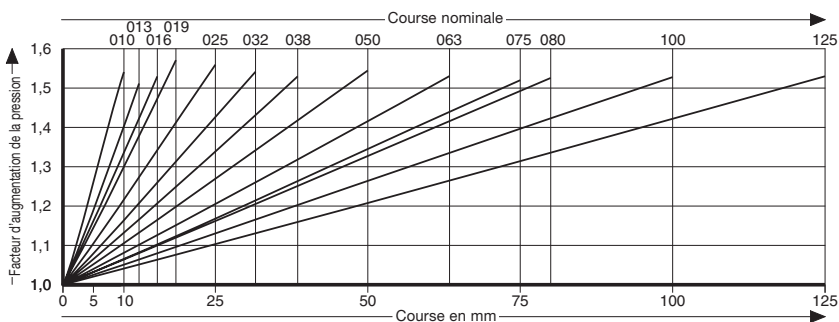

Le facteur d'augmentation de la pression concerne les compressions du volume du gaz en fonction de la course, sans paramètres d'influence!

**RESSORTS A GAZ POUR OUTILLAGES  
FORCE RESSORT ÉLEVÉE "POWER LINE"**

Art. 2487.12.00500

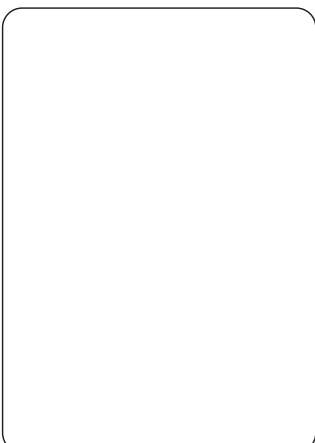
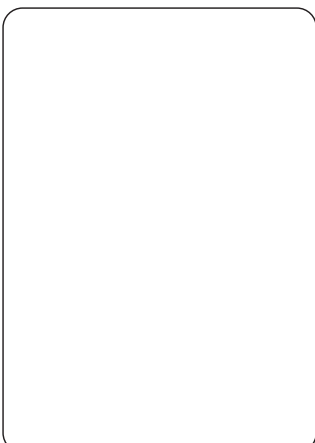
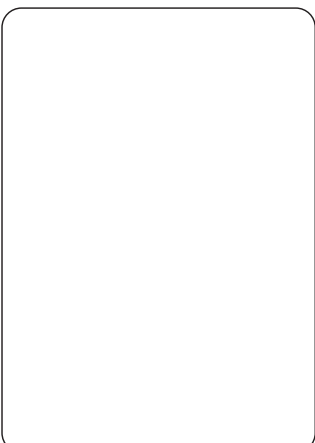
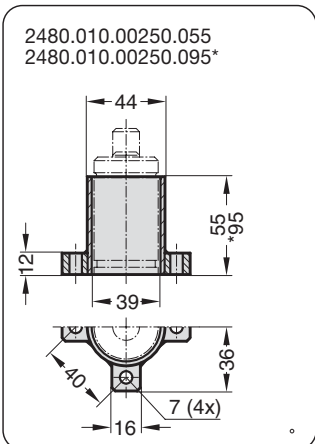
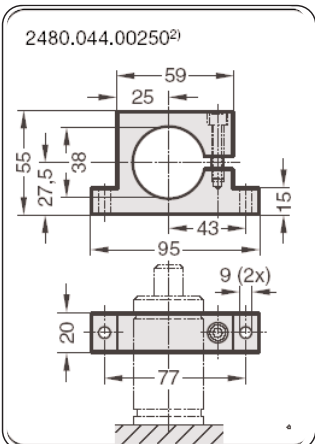
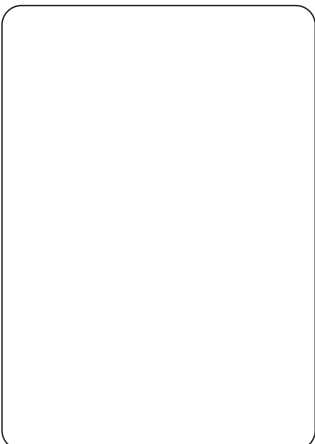
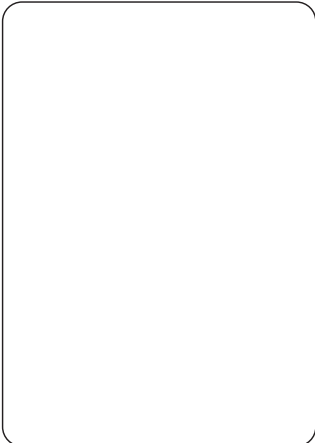
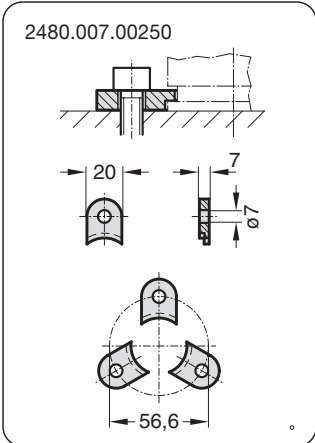
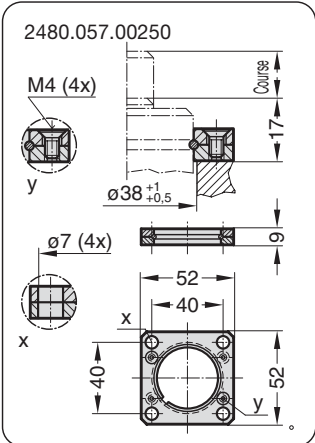
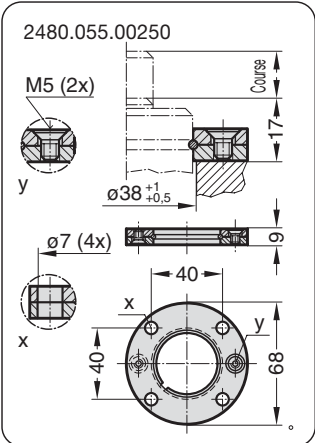
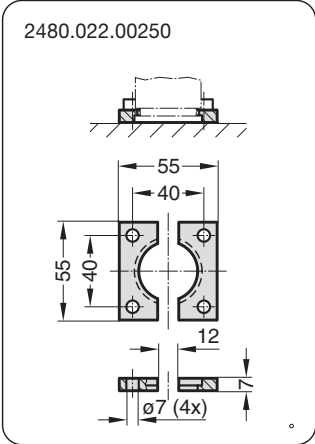
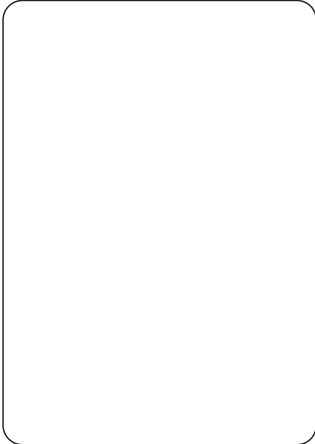
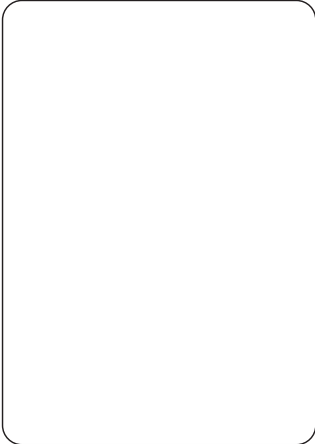
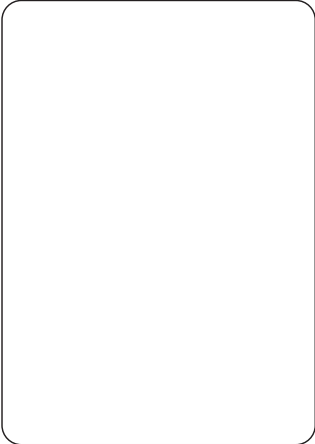

**RESSORTS A GAZ POUR OUTILLAGES  
FORCE RESSORT ÉLEVÉE "POWER LINE"**

Art. 2487.12.00750

**2487.12.00750.**

La force initiale du ressort à 150 bar est de 0750 daN

N° de commande.	Course max.	l <sub>min</sub>	l
2487.12.00750.010	10	42	52
013	13	45	58
016	16	48	64
019	19	51	70
025	25	57	82
032	32	64	96
038	38	70	108
050	50	82	132
063	63	95	158
075	75	107	182
080	80	112	192
100	100	132	232
125	125	157	282

**2487.12.00750.**

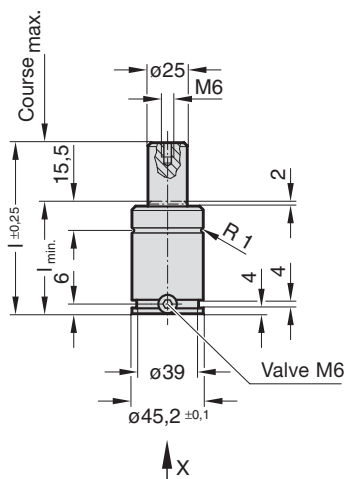

Vue selon X

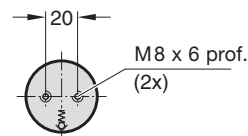

**Indication:**

N° de commande pour jeu de pièces détachées:  
2487.12.00750

Fluide de pression: Azote - N<sub>2</sub>  
 Pression max. de remplissage en gaz: 150 bars  
 Pression min. de remplissage en gaz: 25 bars  
 Température de fonctionnement: 0°C à +80°C  
 Augmentation de force en fonction de la température: ±0,3%/°C  
 Nombre maximal recommandé de courses/minute: env. 20 à 100 (à 20°C)  
 Vitesse maximale du piston: 0,8 m/s

**2487.12.00750.**

Force initiale du ressort en fonction de la pression de remplissage

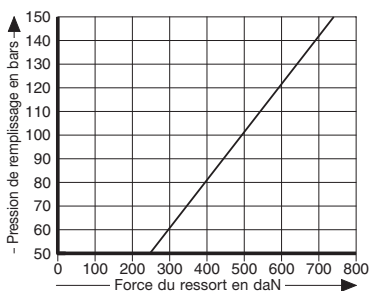

**2487.12.00750.**

Diagramme d'augmentation de la pression en fonction de la course

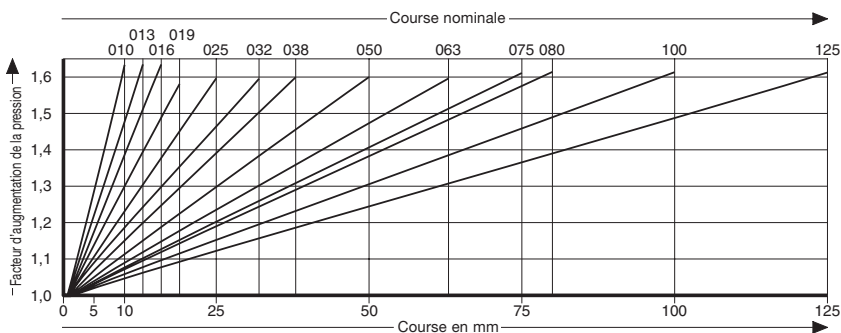

Le facteur d'augmentation de la pression concerne les compressions du volume du gaz en fonction de la course, sans paramètres d'influence!

**RESSORTS A GAZ POUR OUTILLAGES  
FORCE RESSORT ÉLEVÉE "POWER LINE"**

Art. 2487.12.00750

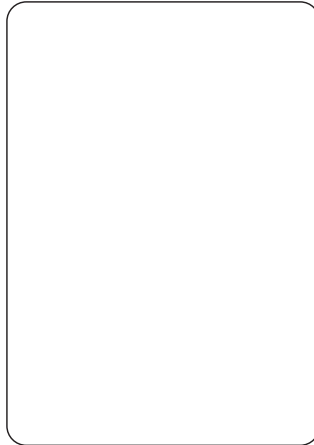
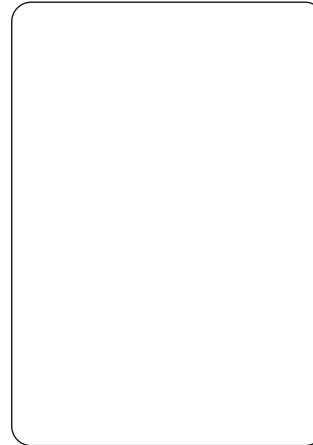
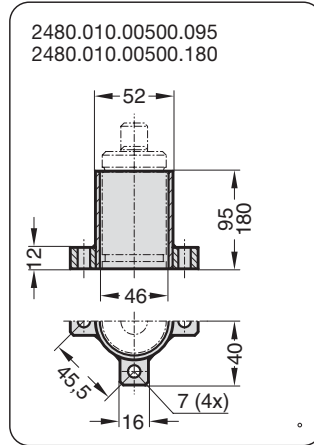
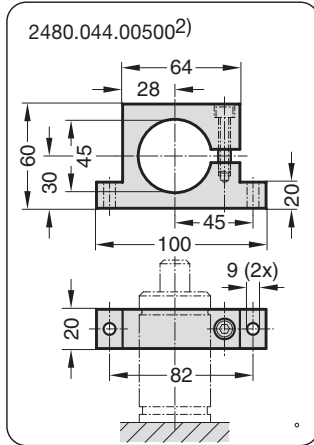
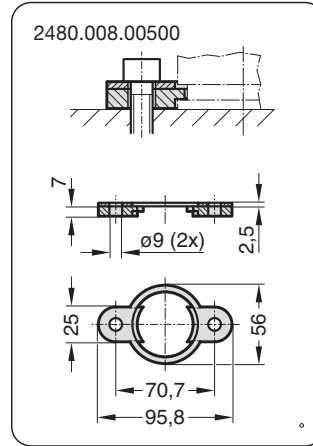
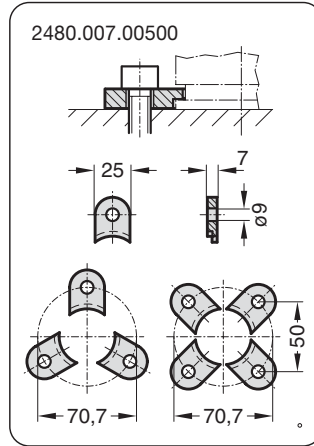
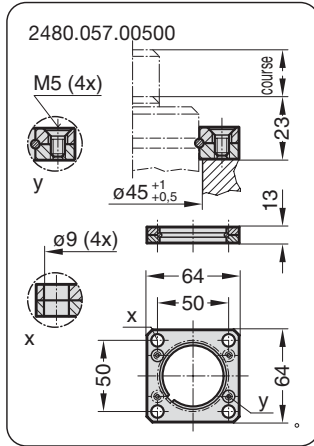
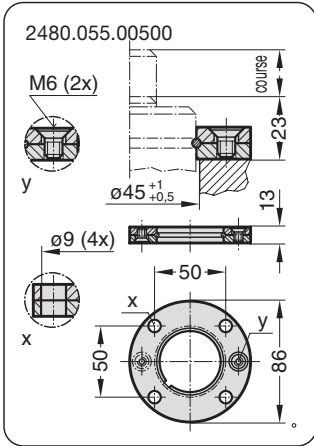
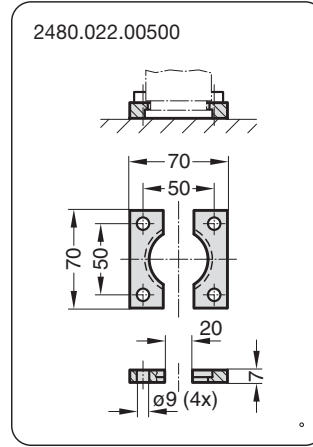
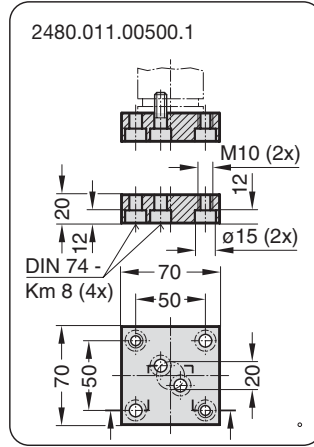
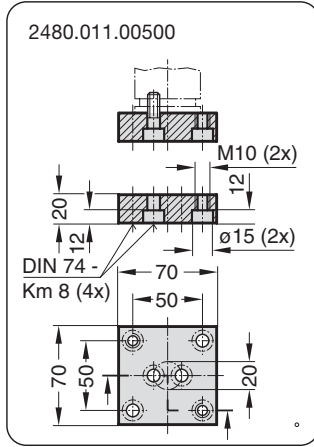

2) Attention:  
La force du ressort doit être supportée par la surface de butée



**RESSORTS A GAZ POUR OUTILLAGES  
FORCE RESSORT ÉLEVÉE "POWER LINE"**

Art. 2487.12.01000

2487.12.01000.

La force initiale du ressort à 150 bar est de 1000 daN

N° de commande.	Course max.	l <sub>min</sub>	l
2487.12.01000.013	13	51	64
016	16	54	70
019	19	57	76
025	25	63	88
032	32	70	102
038	38	76	114
050	50	88	138
063	63	101	164
075	75	113	188
080	80	118	198
100	100	138	238
125	125	163	288

2487.12.01000.

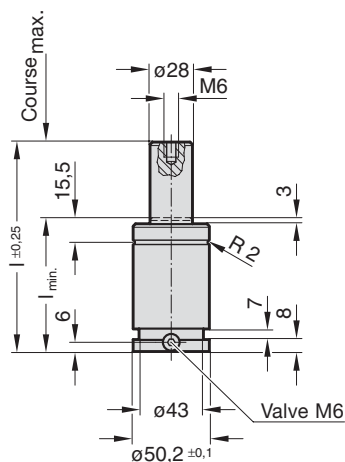

Vue selon X

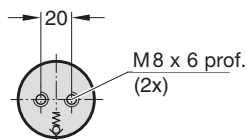

**Indication:**

N° de commande pour jeu de pièces détachées:  
2487.12.01000

Fluide de pression: Azote - N<sub>2</sub>  
 Pression max. de remplissage en gaz: 150 bars  
 Pression min. de remplissage en gaz: 25 bars  
 Température de fonctionnement: 0°C à +80°C  
 Augmentation de force en fonction de la température: ±0,3%/°C  
 Nombre maximal recommandé de courses/minute: env. 20 à 100 (à 20°C)  
 Vitesse maximale du piston: 0,8 m/s

2487.12.01000.

Force initiale du ressort en fonction de la pression de remplissage

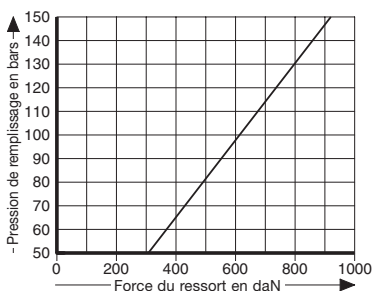

2487.12.01000.

Diagramme d'augmentation de la pression en fonction de la course

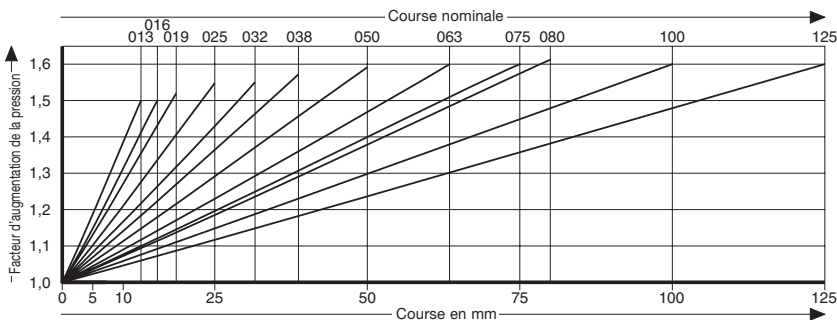

Le facteur d'augmentation de la pression concerne les compressions du volume du gaz en fonction de la course, sans paramètres d'influence!



**RESSORTS A GAZ POUR OUTILLAGES  
FORCE RESSORT ÉLEVÉE "POWER LINE"**

Art. 2487.12.01500

2487.12.01500.

Anfangsfederkraft bei 150 bar ist 1500 daN

Bestell-Nr.	Hub <sub>max.</sub>	l <sub>min.</sub>	l
2487.12.01500.013	13	57	70
016	16	60	76
019	19	63	82
025	25	69	94
032	32	76	108
038	38	82	120
050	50	94	144
063	63	107	170
075	75	119	194
080	80	124	204
100	100	144	244
125	125	169	294

2487.12.01500.

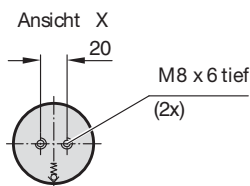
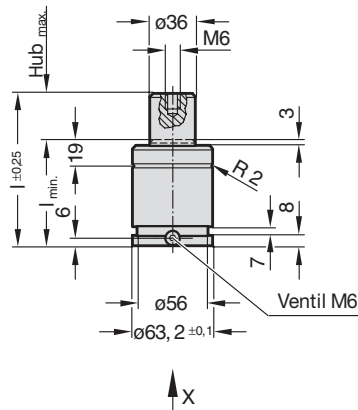

**Hinweis:**

Bestell-Nr. für Ersatzteilsatz:  
2487.12.01500

Druckmedium: Stickstoff – N<sub>2</sub>  
 max. Fülldruck: 150 bar  
 min. Fülldruck: 25 bar  
 Arbeitstemperatur: 0 °C bis +80 °C  
 temperaturabhängiger Kraftanstieg: ±0,3%/°C  
 empfohlene max. Hübe/Minute: ca. 50 bis 100 (bei 20 °C)  
 max. Kolbengeschwindigkeit: 0,8 m/s

2487.12.01500.

Anfangsfederkraft in Abhängigkeit vom Auffülldruck

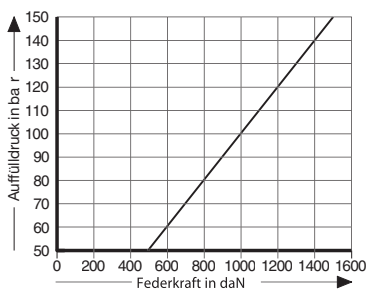

2487.12.01500.

Hubabhängiges Druckaufbaudiagramm

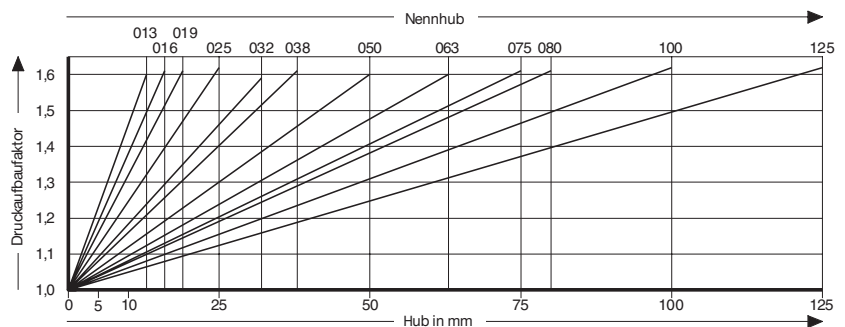

Druckaufbaufaktor gilt für hubabhängige Gasvolumenverdrängung ohne Einflussgrößen!

**RESSORTS A GAZ POUR OUTILLAGES  
FORCE RESSORT ÉLEVÉE "POWER LINE"**

Art. 2487.12.01500

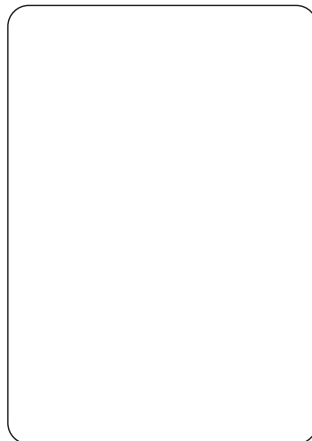
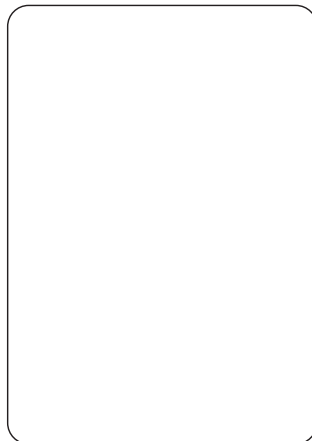
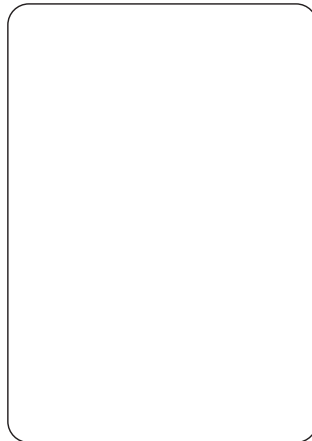
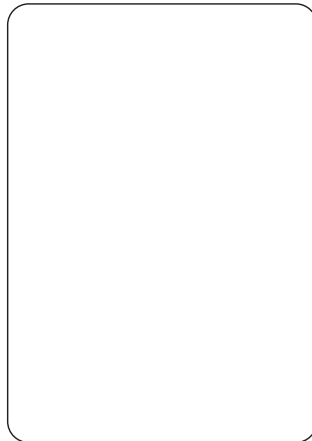
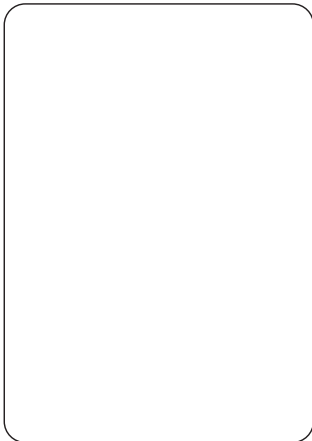
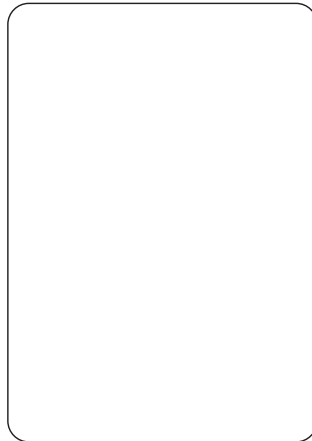
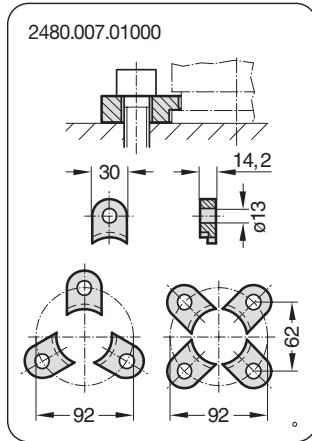
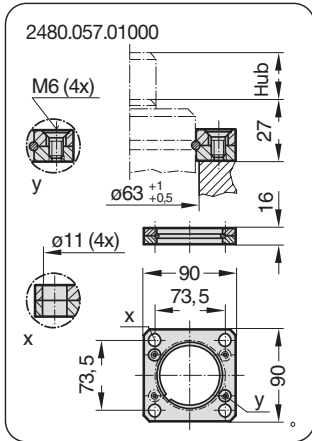
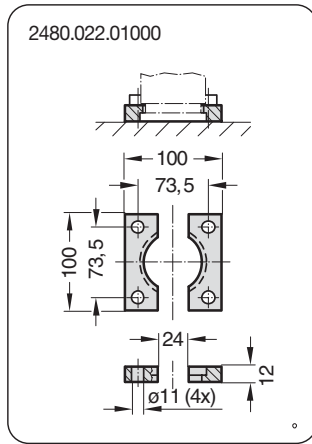
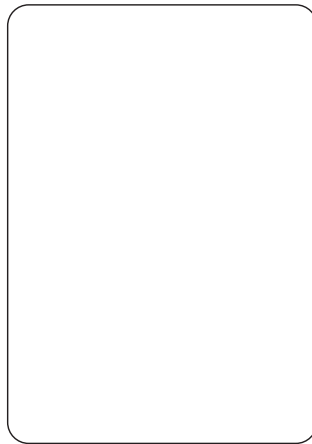
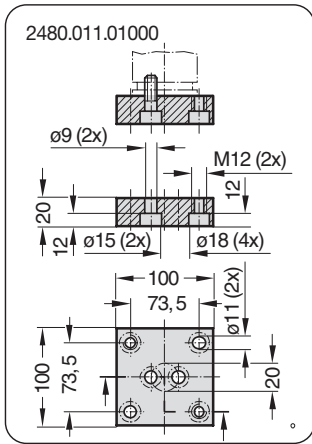
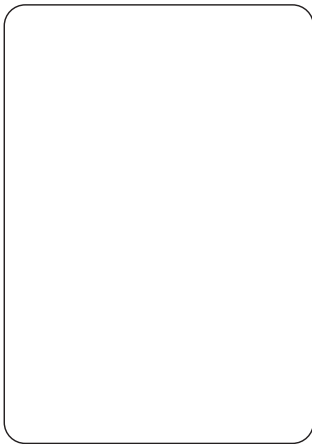

**RESSORTS A GAZ POUR OUTILLAGES  
FORCE RESSORT ÉLEVÉE "POWER LINE"**

Art. 2487.12.02400

**2487.12.02400.**

La force initiale du ressort à 150 bar est de 2400 daN

N° de commande.	Course max.	l <sub>min.</sub>	l
2487.12.02400.016	16	61	77
019	19	64	83
025	25	70	95
032	32	77	109
038	38	83	121
050	50	95	145
063	63	108	171
075	75	120	195
080	80	125	205
100	100	145	245
125	125	170	295

**2487.12.02400.**

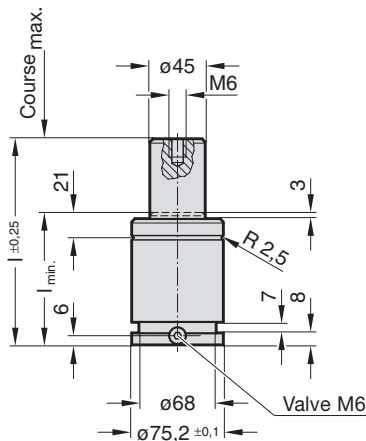

Vue selon X

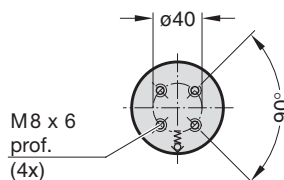

**Indication:**

N° de commande pour jeu de pièces détachées:  
2487.12.02400

Fluide de pression: Azote - N<sub>2</sub>  
 Pression max. de remplissage en gaz: 150 bars  
 Pression min. de remplissage en gaz: 25 bars  
 Température de fonctionnement: 0°C à +80°C  
 Augmentation de force en fonction de la température: ±0,3%/°C  
 Nombre maximal recommandé de courses/minute: env. 20 à 100 (à 20°C)  
 Vitesse maximale du piston: 0,8 m/s

**2487.12.02400.**

Force initiale du ressort en fonction de la pression de remplissage

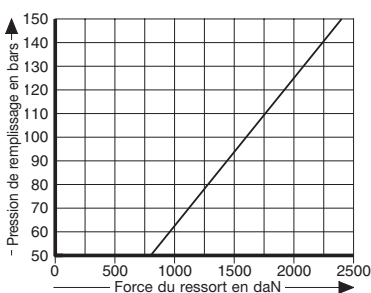

**2487.12.02400.**

Diagramme d'augmentation de la pression en fonction de la course

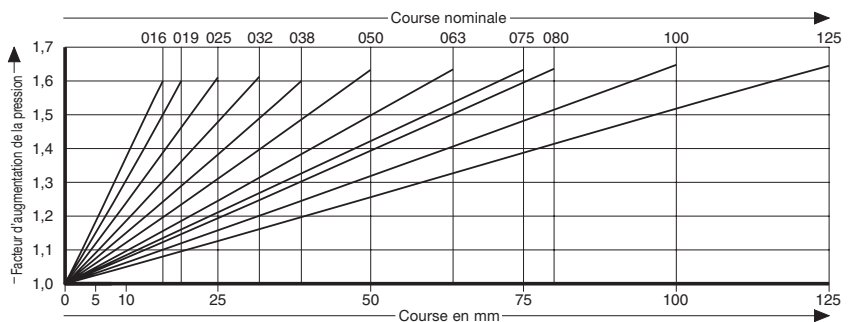

Le facteur d'augmentation de la pression concerne les compressions du volume du gaz en fonction de la course, sans paramètres d'influence!



**RESSORTS A GAZ POUR OUTILLAGES  
FORCE RESSORT ÉLEVÉE "POWER LINE"**

Art. 2487.12.04200

**2487.12.04200.**

La force initiale du ressort à 150 bar est de 4200 daN

N° de commande.	Course max.	$l_{min}$	l
2487.12.04200.016	16	74	90
019	19	77	96
025	25	83	108
032	32	90	122
038	38	96	134
050	50	108	158
063	63	121	184
075	75	133	208
080	80	138	218
100	100	158	258
125	125	183	308

**2487.12.04200.**

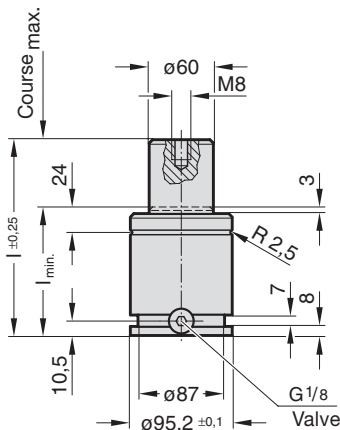

↑ X

Vue selon X

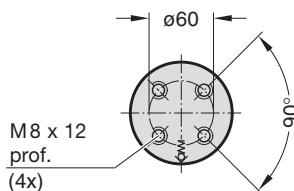

**Indication:**

N° de commande pour jeu de pièces détachées:  
2487.12.04200

Fluide de pression: Azote - N<sub>2</sub>  
 Pression max. de remplissage en gaz: 150 bars  
 Pression min. de remplissage en gaz: 25 bars  
 Température de fonctionnement: 0°C à +80°C  
 Augmentation de force en fonction de la température: ±0,3%/°C  
 Nombre maximal recommandé de courses/minute: env. 20 à 100 (à 20°C)  
 Vitesse maximale du piston: 0,8 m/s

**2487.12.04200.**

Force initiale du ressort en fonction de la pression de remplissage

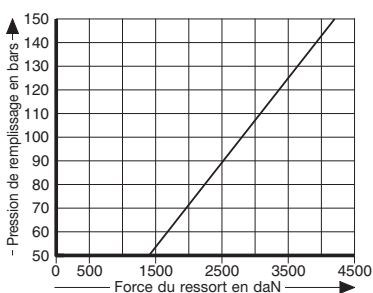

**2487.12.04200.**

Diagramme d'augmentation de la pression en fonction de la course

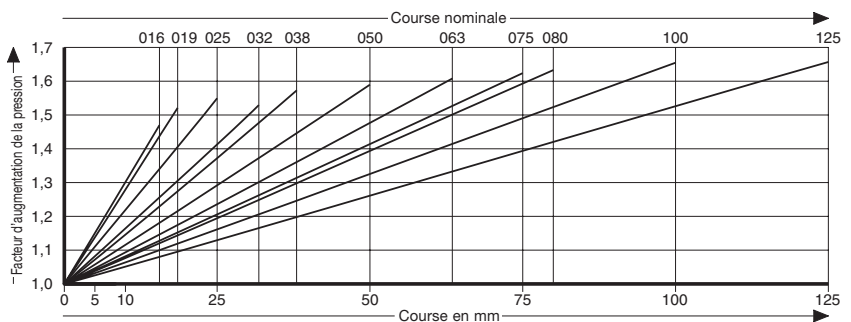

Le facteur d'augmentation de la pression concerne les compressions du volume du gaz en fonction de la course, sans paramètres d'influence!

**RESSORTS A GAZ POUR OUTILLAGES  
FORCE RESSORT ÉLEVÉE "POWER LINE"**

Art. 2487.12.04200

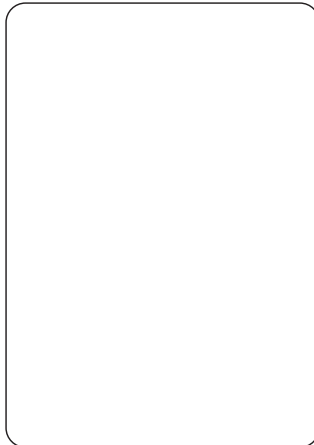
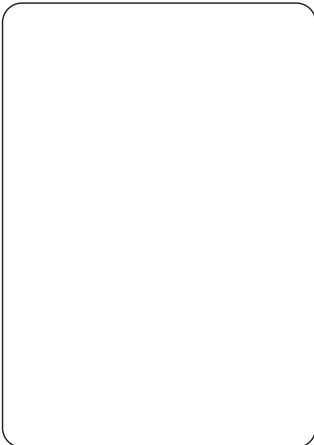
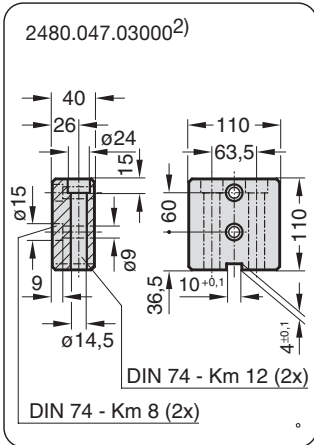
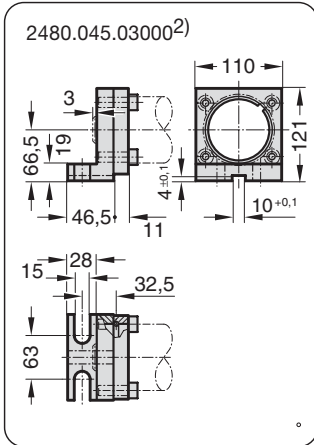
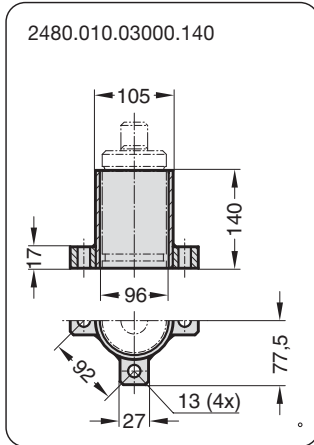
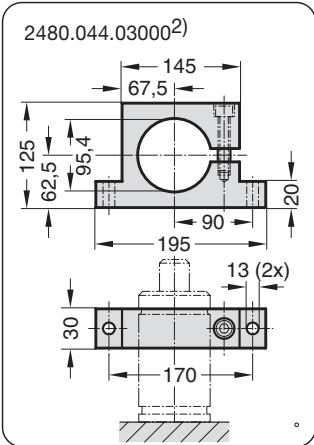
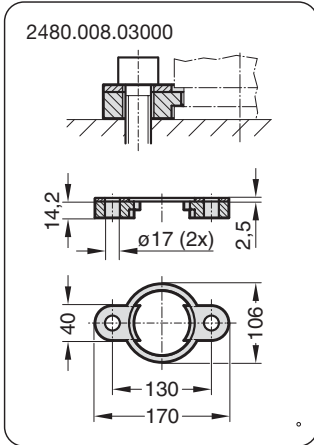
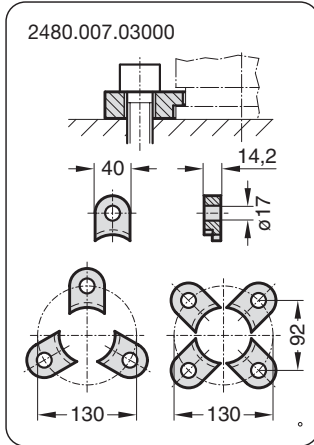
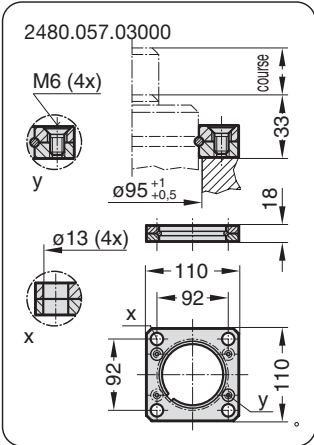
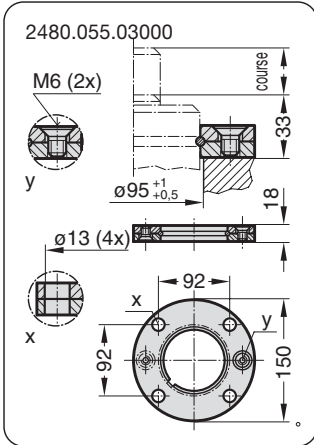
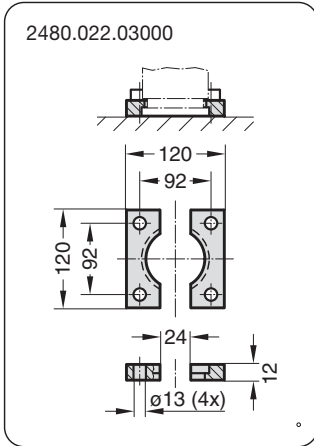
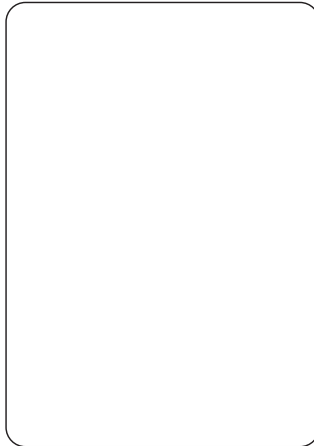
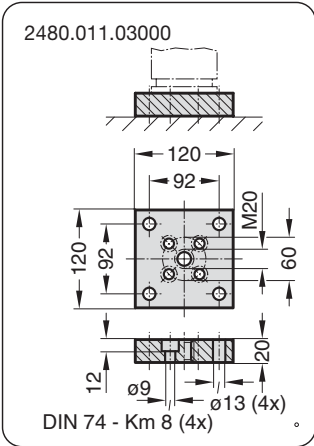

2) Attention:  
La force du ressort doit être supportée par la surface de butée



**RESSORTS A GAZ POUR OUTILLAGES  
FORCE RESSORT ÉLEVÉE "POWER LINE"**

Art. 2487.12.06600

**2487.12.06600.**

La force initiale du ressort à 150 bar est de 6630 daN

N° de commande.	Course max.	$l_{min}$	$l$
2487.12.06600.016	16	84	100
019	19	87	106
025	25	93	118
032	32	100	132
038	38	106	144
050	50	118	168
063	63	131	194
075	75	143	218
080	80	148	228
100	100	168	268
125	125	193	318

**2487.12.06600.**

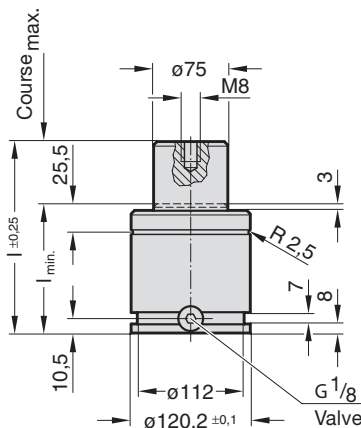

Vue selon X

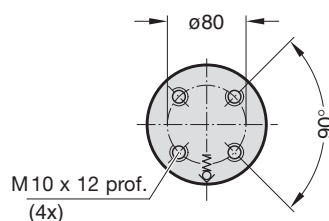

**Indication:**

N° de commande pour jeu de pièces détachées:  
2487.12.06600

Fluide de pression: Azote - N<sub>2</sub>  
 Pression max. de remplissage en gaz: 150 bars  
 Pression min. de remplissage en gaz: 25 bars  
 Température de fonctionnement: 0°C à +80°C  
 Augmentation de force en fonction de la température: ±0,3%/°C  
 Nombre maximal recommandé de courses/minute: env. 20 à 100 (à 20°C)  
 Vitesse maximale du piston: 0,8 m/s

**2487.12.06600.**

Force initiale du ressort en fonction de la pression de remplissage

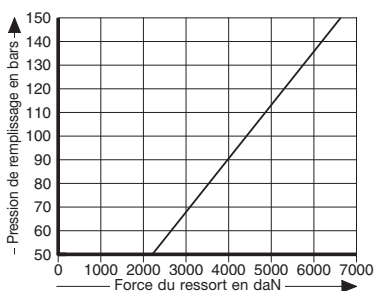

**2487.12.06600.**

Diagramme d'augmentation de la pression en fonction de la course

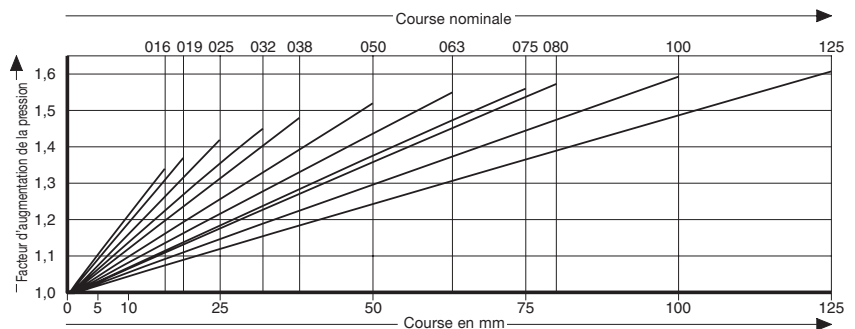

Le facteur d'augmentation de la pression concerne les compressions du volume du gaz en fonction de la course, sans paramètres d'influence!

**RESSORTS A GAZ POUR OUTILLAGES  
FORCE RESSORT ÉLEVÉE "POWER LINE"**

Art. 2487.12.06600

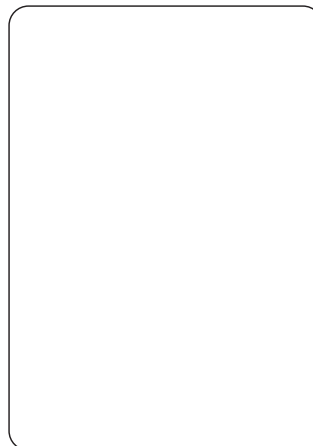
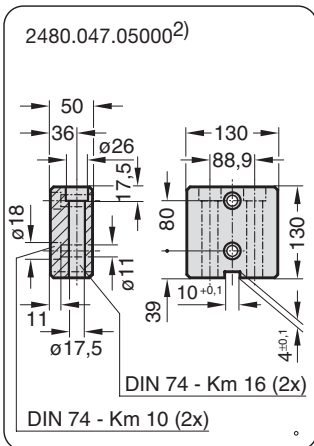
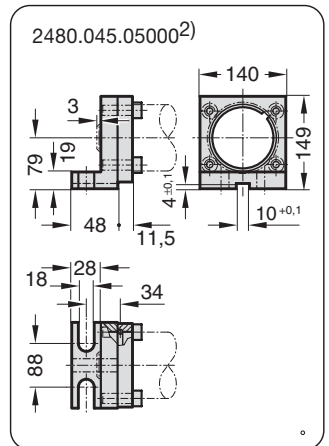
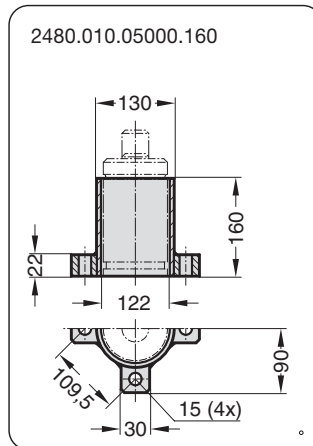
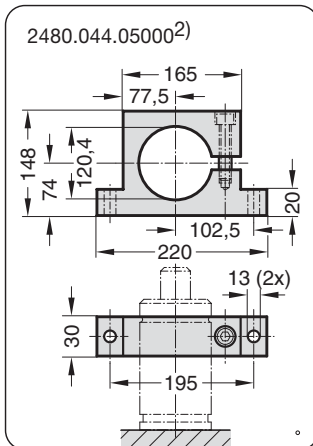
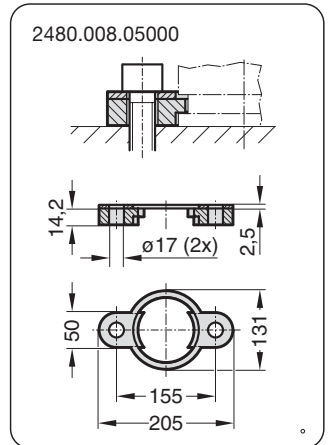
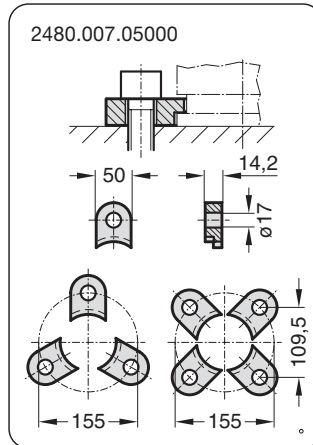
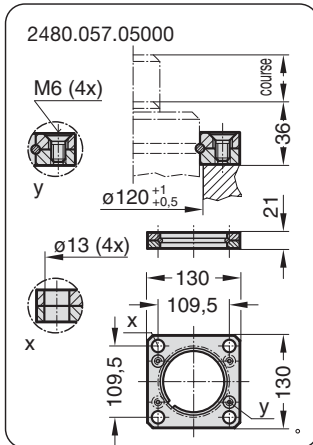
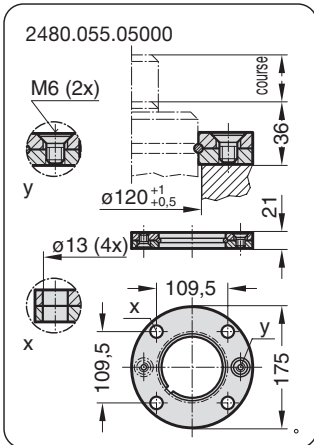
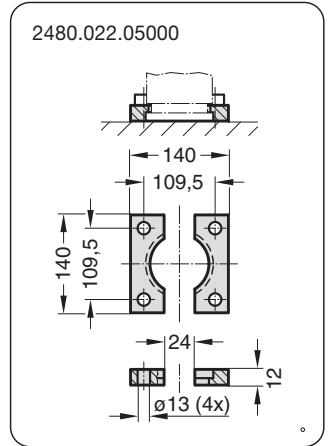
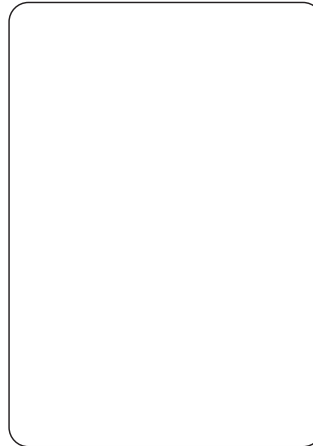
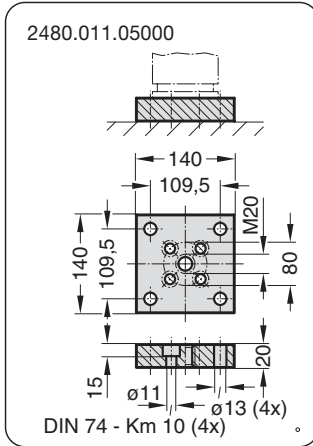

2) Attention:  
La force du ressort doit être supportée par la surface de butée

**RESSORTS A GAZ POUR OUTILLAGES  
FORCE RESSORT ÉLEVÉE "POWER LINE"**

Art. 2487.12.09500

2487.12.09500.

Anfangsfederkraft bei 150 bar ist 9500 daN

Bestell-Nr.		Hub max.	$l_{min.}$	$l$
2487.12.09500.	019	19	97	116
	025	25	103	128
	032	32	110	142
	038	38	116	154
	050	50	128	178
	063	63	141	204
	075	75	153	228
	080	80	158	238
	100	100	178	278
	125	125	203	328

2487.12.09500.

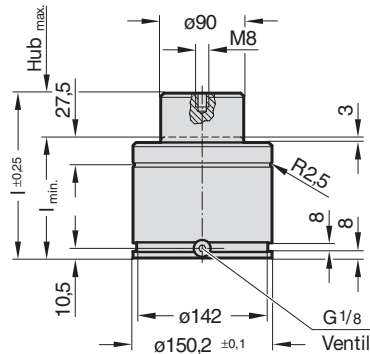

↑ X

Ansicht X

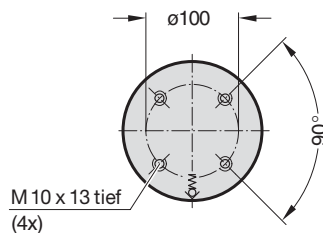

**Hinweis:**

Bestell-Nr. für Ersatzteilsatz:  
2487.12.09500

Druckmedium: Si Stickstoff – N<sub>2</sub>  
 max. Fülldruck: 150 bar  
 min. Fülldruck: 25 bar  
 Arbeitstemperatur: 0 °C bis +80 °C  
 temperaturabhängiger  
 Kraftanstieg: ±0,3%/°C  
 empfohlene max.  
 Hübe/Minute: ca. 20 bis 100  
 (bei 20 °C)  
 max. Kolben-  
 geschwindigkeit: 0,8 m/s

2487.12.09500.

Anfangsfederkraft in  
Abhängigkeit vom Auffülldruck

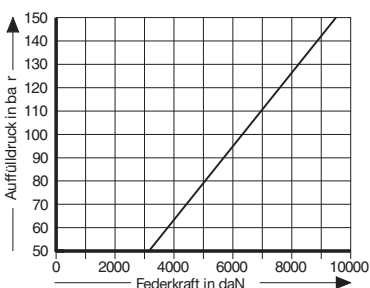

2487.12.09500.

Hubabhängiges Druckaufbaudiagramm

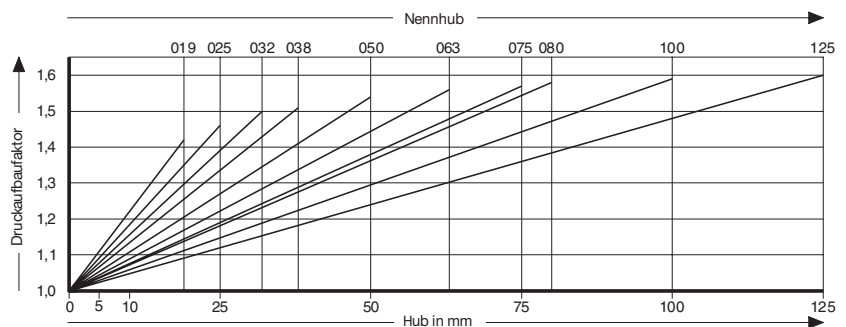

Druckaufbaufaktor gilt für hubabhängige Gasvolumenverdrängung ohne Einflussgrößen!

**RESSORTS A GAZ POUR OUTILLAGES  
FORCE RESSORT ÉLEVÉE "POWER LINE"**

Art. 2487.12.09500

2480.011.07500

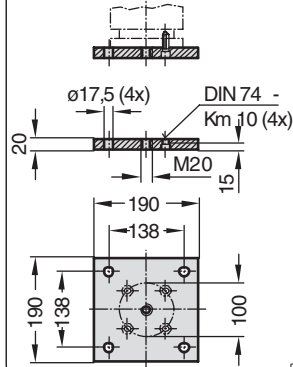

2480.022.07500

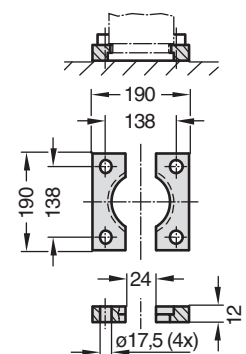

2480.055.07500

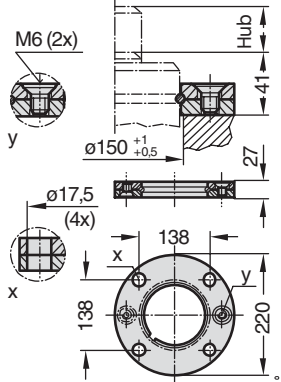

2480.057.07500

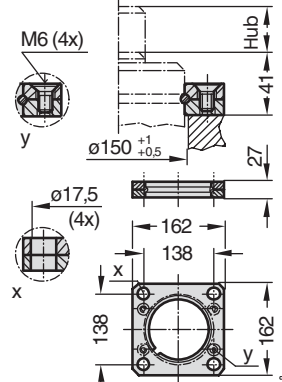

2480.007.07500

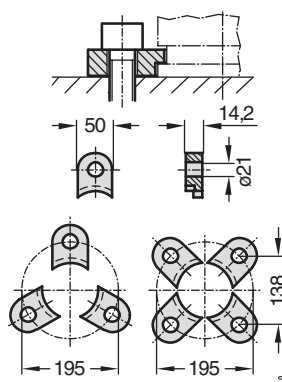

2480.008.07500

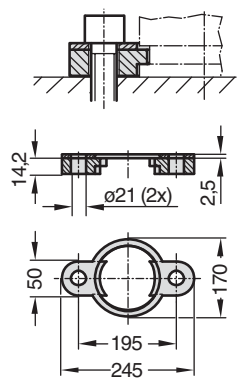

2480.044.07500 <sup>2)</sup>

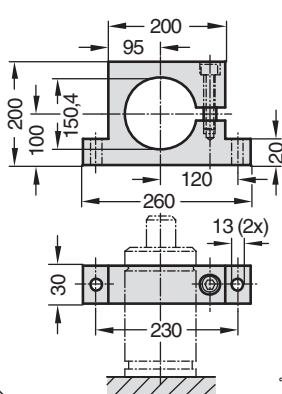

<sup>2)</sup> Achtung:  
Federkraft muss durch  
Anschlagfläche aufge-  
nommen werden.