

**PATINS BRONZE OU ACIER  
"NAAMS"**

Art. 2963.82/83

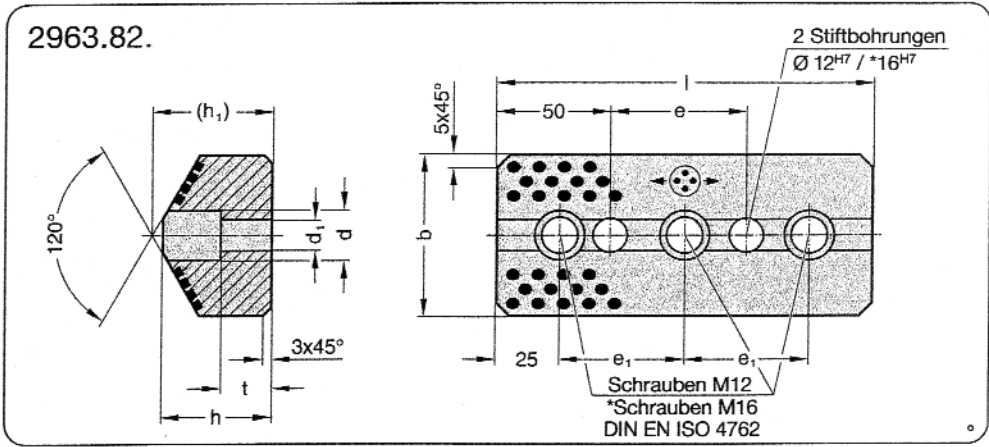
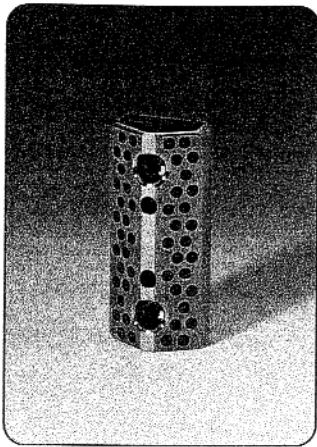

2963.82.

Bestell-Nr.	b	h	(h <sub>1</sub> )	l	e	e <sub>1</sub>	d	d <sub>1</sub>	t	Anzahl Schrauben
2963.82.065.039.0150	65	39	(42)	150	50	100	20	13,5	13	2
0200				200	100	150				2
0250				250	150	100				3
0300				300	200	125				3
2963.82.075.039.0150	75	39	(42)	150	50	100	20	13,5	13	2
0200				200	100	150				2
0250				250	150	100				3
0300				300	200	125				3
2963.82.125.052.0150*	125	52	(57)	150	50	100	20	17,5	15	2
0200*				200	100	150				2
0250*				250	150	100				3
0300*				300	200	125				3

**Werkstoff:**  
Bronze mit Festschmierstoff, wartungsarm.

**Ausführung:**  
Gleitflächen geschliffen

**Hinweis:**  
Lieferung ohne Schrauben und Stifte.

**Bestell-Beispiel:**

Gleitstück = 2963.82.  
 b = 65 mm = 065.  
 h = 39 mm = 039.  
 l = 200 mm = 0200  
 Bestell-Nr. = 2963.82.065.039.0200

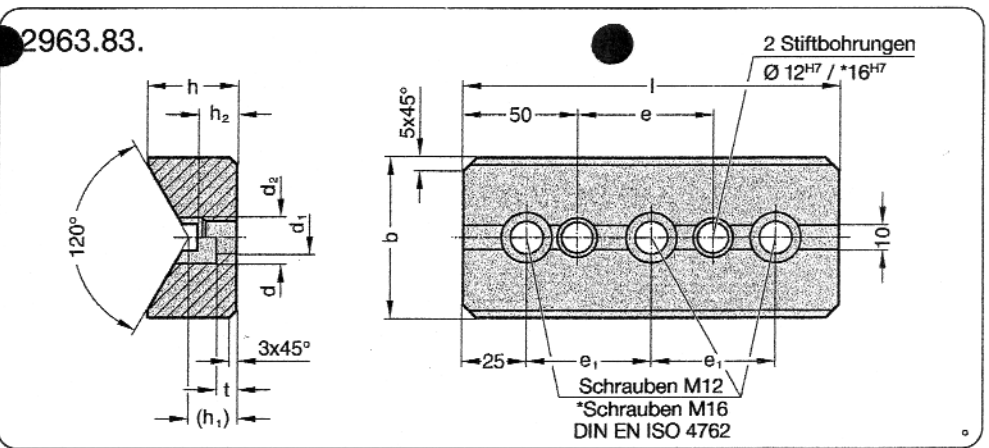
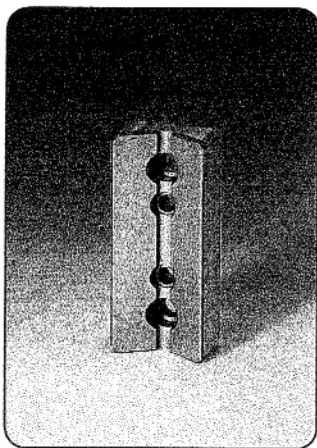

2963.83.

Bestell-Nr.	b	h	(h <sub>1</sub> )	h <sub>2</sub>	l	e	e <sub>1</sub>	d	d <sub>1</sub>	d <sub>2</sub>	t	Anzahl Schrauben
2963.83.065.040.0150	65	40	(23)	21	150	50	100	20	13,5	14	10	2
0200					200	100	150					2
0250					250	150	100					3
0300					300	200	125					3
2963.83.075.040.0150	75	40	(23)	21	150	50	100	20	13,5	14	10	2
0200					200	100	150					2
0250					250	150	100					3
0300					300	200	125					3
2963.83.125.060.0150*	125	60	(28)	27	150	50	100	26	17,5	18	15	2
0200*					200	100	150					2
0250*					250	150	100					3
0300*					300	200	125					3

**Werkstoff:**  
Stahl, Gleitflächen oberflächengehärtet.

**Hinweis:**  
Lieferung ohne Schrauben und Stifte.

**Bestell-Beispiel:**

Prismenführung = 2963.83.  
 b = 65 mm = 065.  
 h = 40 mm = 040.  
 l = 200 mm = 0200  
 Bestell-Nr = 2963.83.065.040.0200

**PATIN  
VDI 3357**

Art. 2963.84/85

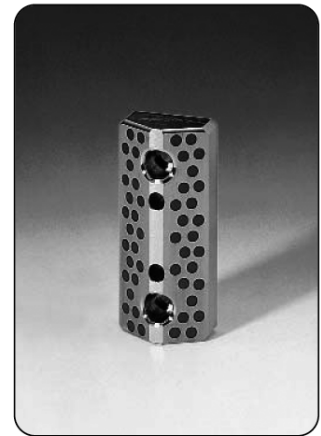
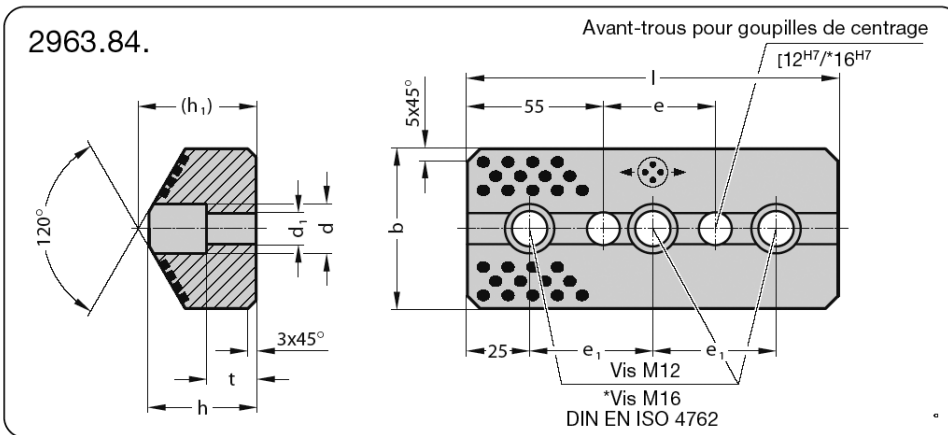

N° de commande	b	h	(h <sub>1</sub> )	h <sub>3</sub>	l	e	e <sub>1</sub>	d	d <sub>1</sub>	t	Nombre de vis
2963.84.065.044.0150	65	44	(47)	65	150	45	100	20	13,5	20	2
0200					200	95	150				2
0250					250	145	100				3
0300					300	195	125				3
2963.84.125.047.0150*	125	47	(52)	85	150	45	100	26	17,5	15	2
0200*					200	95	150				2
0250*					250	145	100				3
0300*					300	195	125				3
2963.84.125.052.0150*	125	52	(57)	85	150	45	100	26	17,5	15	2
0200*					200	95	150				2
0250*					250	145	100				3
0300*					300	195	125				3

**Matière :**

Bronze avec inserts autolubrifiants.

**Indication :**

Livraison sans les vis et sans les goupilles.

**Exemple de commande :**

Patin coulissant = 2963.84.  
b = 65 mm = 065.  
h = 44 mm = 044.  
l = 200 mm = 0200  
N° de commande = 2963.84.065.044.0200

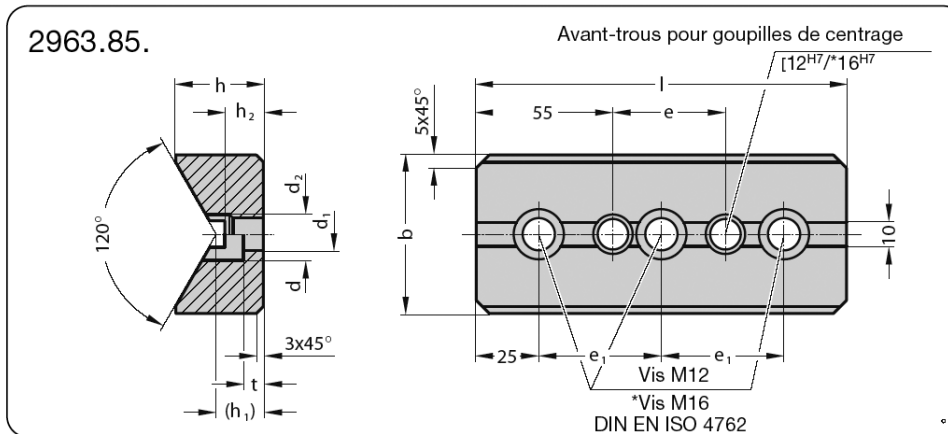

N° de commande	b	h	(h <sub>1</sub> )	h <sub>2</sub>	l	e	e <sub>1</sub>	d	d <sub>1</sub>	d <sub>2</sub>	t	Nombre de vis
2963.85.065.035.0150	65	35	(18)	17	65	150	45	100	20	13,5	14	8
0200					200	95	150					2
0250					250	145	100					3
0300					300	195	125					3
2963.85.125.060.0150*	125	60	(33)	32	85	150	45	100	26	17,5	18	15
0200*					200	95	150					2
0250*					250	145	100					3
0300*					300	195	125					3
2963.85.125.060.0150.1*	125	60	(28)	27	x	150	45	100	26	17,5	18	15
0200*					200	95	150					2
0250*					250	145	100					3
0300*					300	195	125					3

**Matière :**

Acier  
Surfaces de glissement trempées superficiellement.

**Indication :**

Livraison sans les vis et sans les goupilles.

**Exemple de commande :**

Glissière prismatique = 2963.85.  
b = 65 mm = 065.  
h = 35 mm = 035

**GLISSIÈRES BRONZE OU ACIER**

Art. 2963.70/71

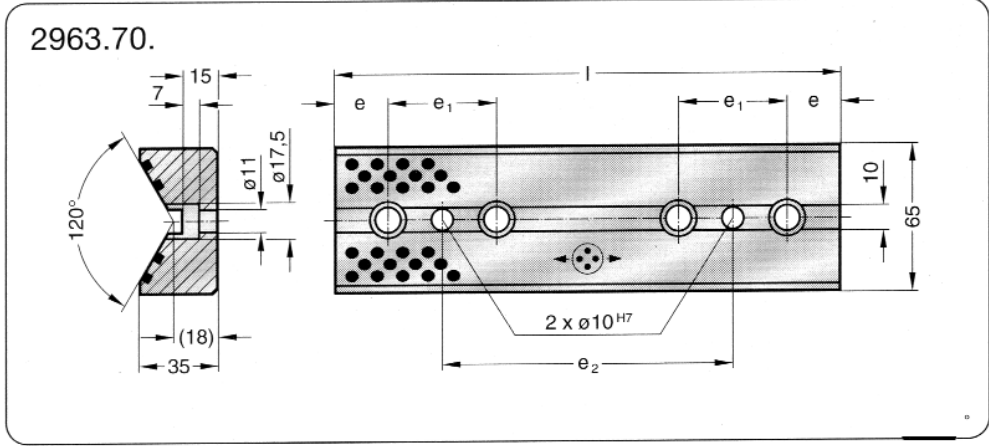
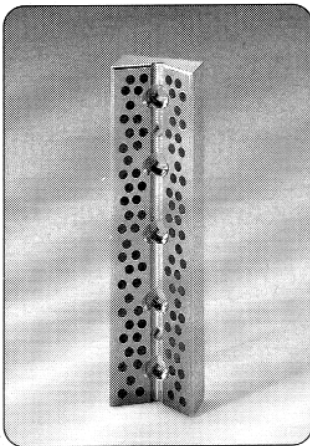

**Werkstoff:**  
Bronze mit Festschmierstoff, wartungsarm.

**Hinweis:**  
Lieferung ohne Schrauben und Stifte.

 Gleitrichtung Festschmierstoff-Einsätze (Ausschnitt)

2963.70.

Bestell.-Nr.	e	e <sub>1</sub>	e <sub>2</sub>	l	Anzahl Schrauben
2963.70.065.035.0100	20	60	20	100	2
0150	25	50	50	150	3
0200			100	200	4
0250			150	250	5
0300			200	300	6

**Bestell-Beispiel:**  
Prismenführung = 2963.70.  
Breite = 65 mm = 065.  
Dicke = 35 mm = 035.  
l = 250 mm = 0250  
Bestell-Nummer = 2963.70.065.035.0250

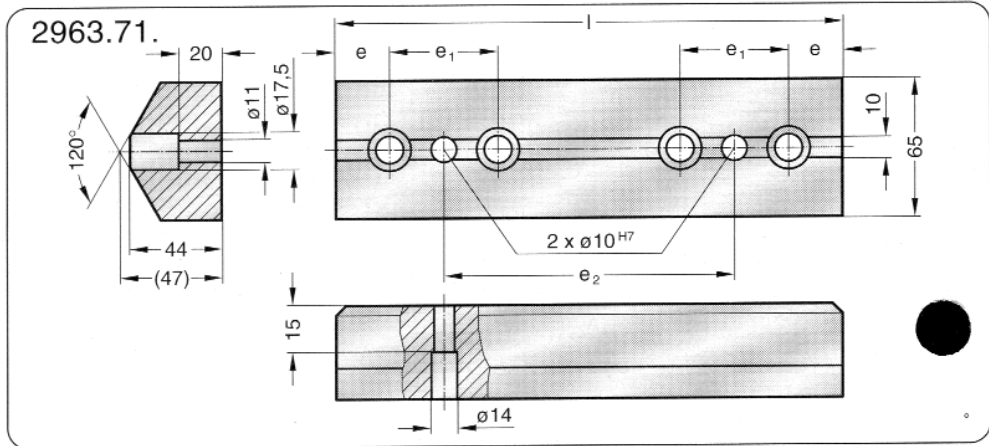
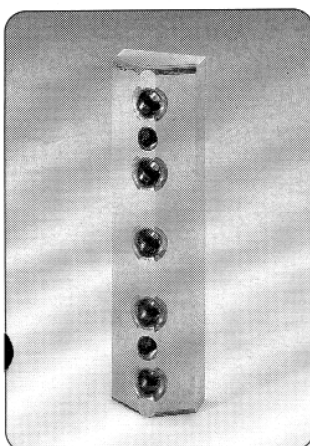

**Werkstoff:**  
Stahl  
Gleitflächen oberflächengehärtet.

**Hinweis:**  
Lieferung ohne Schrauben und Stifte.

2963.71.

Bestell.-Nr.	e	e <sub>1</sub>	e <sub>2</sub>	l	Anzahl Schrauben
2963.71.065.044.0100	20	60	20	100	2
0150	25	50	50	150	3
0200			100	200	4
0250			150	250	5
0300			200	300	6

**Bestell-Beispiel:**  
Gleitstück = 2963.71.  
Breite = 65 mm = 065.  
Dicke = 44 mm = 044.  
l = 300 mm = 0300  
Bestell-Nummer = 2963.71.065.044.0300

**GLISSIÈRES BRONZE OU ACIER**

Art. 2963.72/73

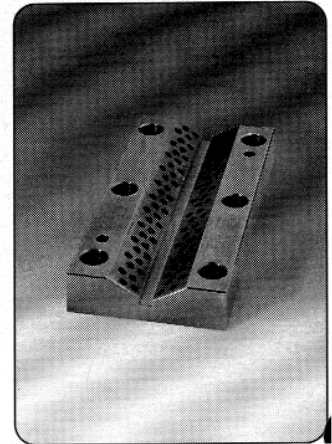
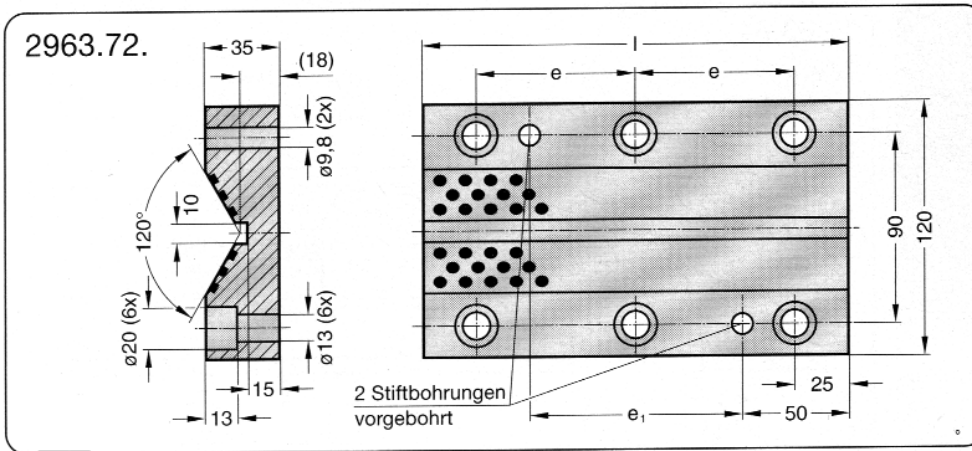

2963.72.

Bestell-Nr.	l	e	e <sub>1</sub>	Anzahl Schrauben
2963.72.120.035.0150	150	50	50	6
0200	200	75	100	6
0250	250	100	150	6
0300	300	125	200	6

**Bestell-Beispiel:**

Prismenführung = 2963.72.  
 Breite = 120 mm = 120.  
 Dicke = 35 mm = 035.  
 l = 150 mm = 0150  
 Bestell-Nummer = 2963.72.120.035.0150

**Werkstoff:**

Bronze mit Festschmierstoff, wartungsarm.

**Hinweis:**

Lieferung ohne Schrauben und Stifte.



Gleitrichtung  
 Festschmierstoff-Einsätze  
 (Ausschnitt)

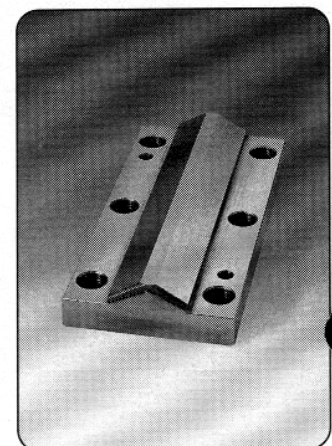
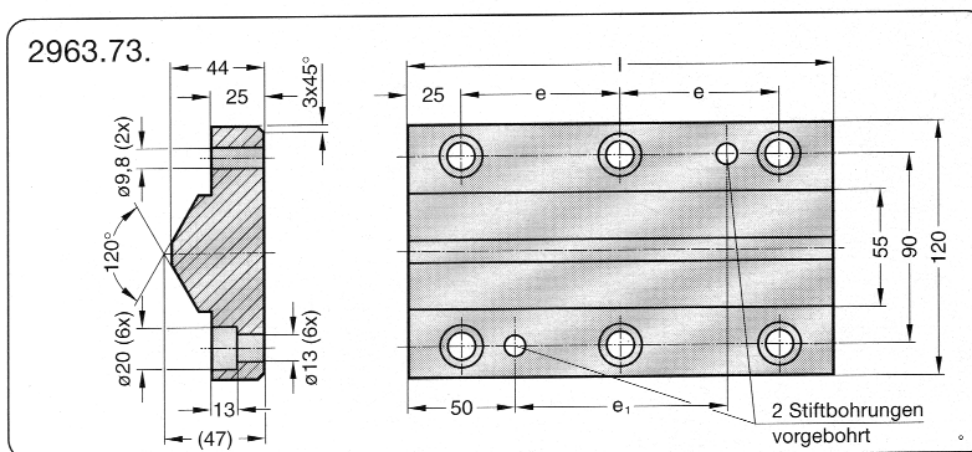

2963.73.

Bestell-Nr.	l	e	e <sub>1</sub>	Anzahl Schrauben
2963.73.120.044.0150	150	50	50	6
0200	200	75	100	6
0250	250	100	150	6
0300	300	125	200	6

**Bestell-Beispiel:**

Gleitstück = 2963.73.  
 Breite = 120 mm = 120.  
 Dicke = 44 mm = 044.  
 l = 150 mm = 0150  
 Bestell-Nummer = 2963.73.120.044.0150

**Werkstoff:**

Stahl  
 Gleitflächen oberflächengehärtet.

**Hinweis:**

Lieferung ohne Schrauben und Stifte.

**GLISSIÈRES EN ACIER**

**Art. 2963.81**

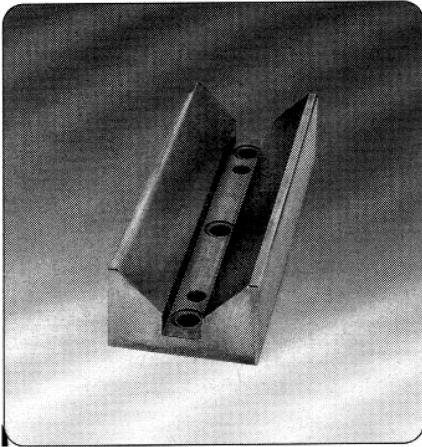

2963.81.

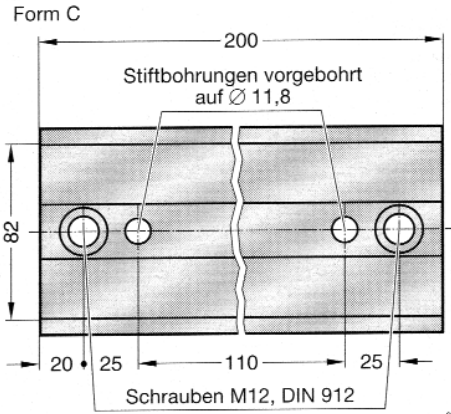
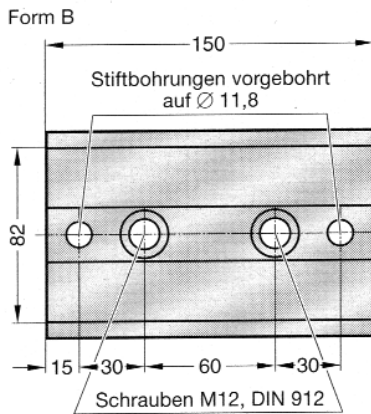
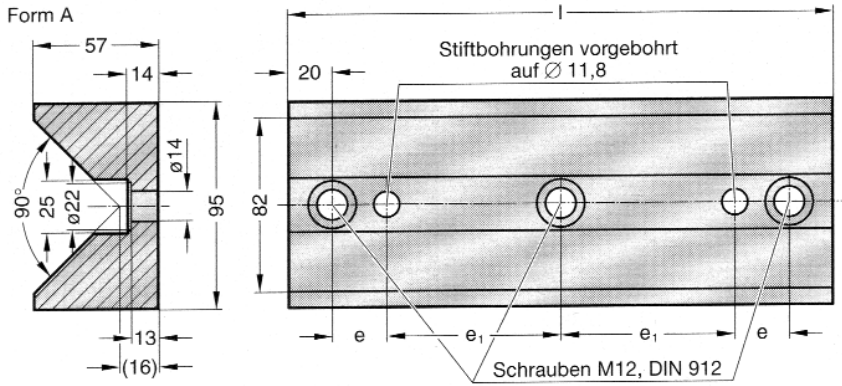

**Werkstoff:**  
 Stahl  
 Gleitflächen oberflächengehärtet.

**Hinweis:**  
 Lieferung ohne Schrauben und Stifte.

2963.81.

Bestell-Nr.	Form	l	e	e <sub>1</sub>	Anzahl Schrauben
2963.81.095.057.0150	B	150	30	-	2
0200	C	200	25	-	2
0250	A	250	25	80	3
0300	A	300	30	100	3

**Bestell-Beispiel:**

Prismenführung = 2963.81.  
 Breite = 95 mm = 095.  
 Dicke = 57 mm = 057.  
 l = 250 mm = 0250  
 Bestell-Nummer = 2963.81.095.057.0250

**PATINS**

**Art. 2963.80**

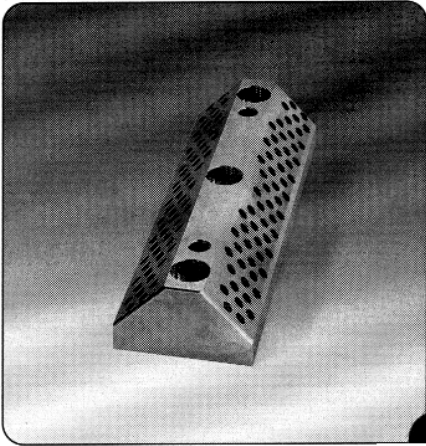
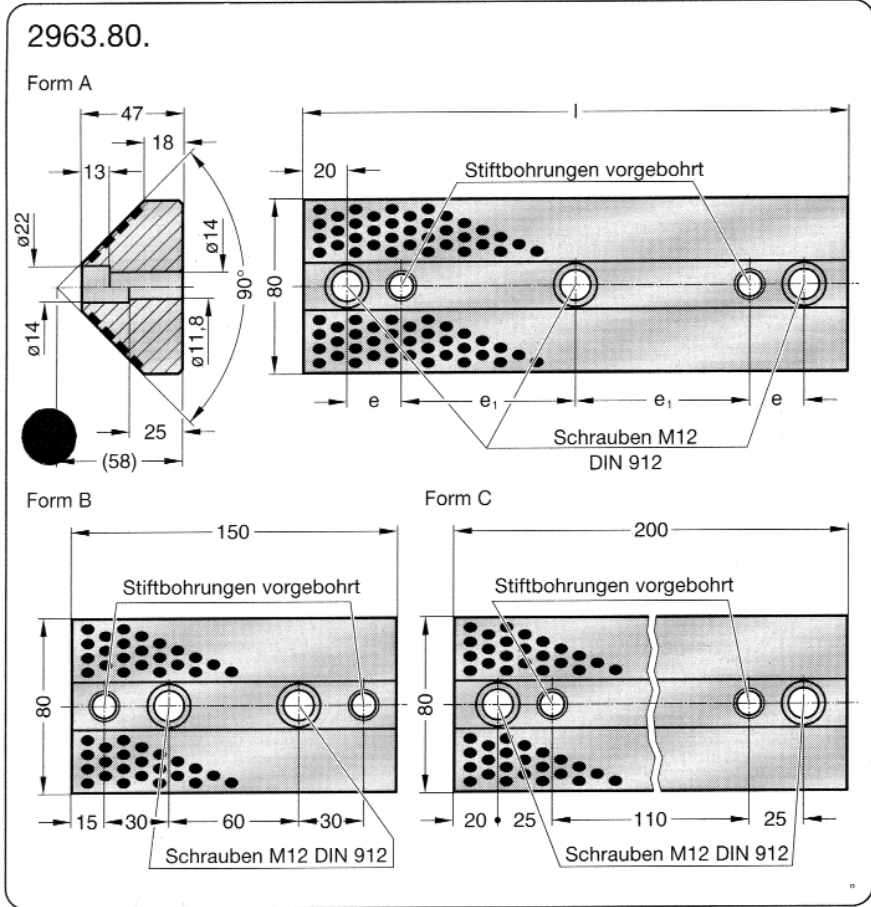

**Werkstoff:**

Bronze mit Festschmierstoff, wartungsarm.

**Hinweis:**

Lieferung ohne Schrauben und Stifte.

**2963.80.**

Bestell-Nr.	Form	l	e	e <sub>1</sub>	Anzahl Schrauben
2963.80.080.047.0150	B	150	30	-	2
0200	C	200	25	-	2
0250	A	250	25	80	3
0300	A	300	30	100	3

**Bestell-Beispiel:**

Gleitstück	=	2963.80.
Breite = 80 mm	=	080.
Dicke = 47 mm	=	047.
l = 250 mm	=	0250
Bestell-Nummer	=	2963.80.080.047.0250

**GLISSIÈRES**

**Art. 2965.81**

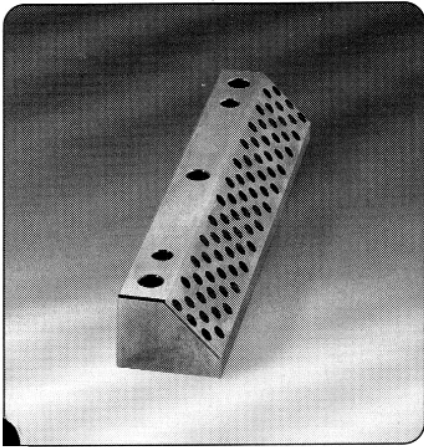

**2965.81.**

Form A

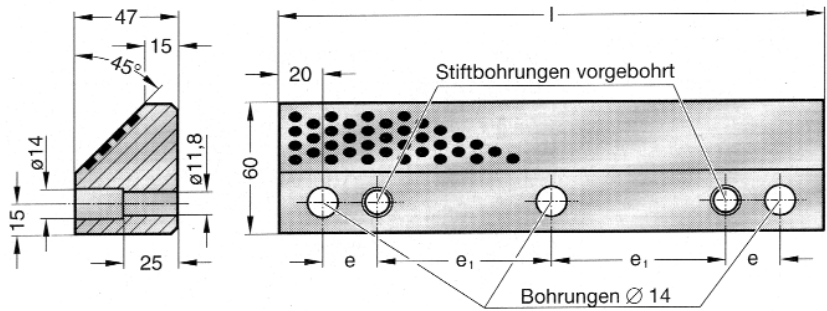

Form B

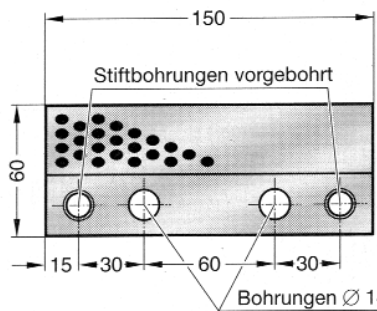

Form C

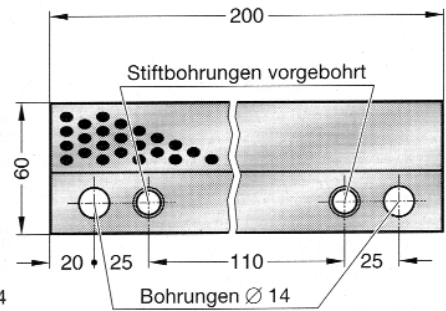

**Werkstoff:**

Bronze mit Festschmierstoff, wartungsarm.

**Hinweis:**

Einseiten-Prismen-Gleitstücke 2965.83. siehe gegenüberliegende Seite.  
Lieferung ohne Schrauben und Stifte.

**2965.81.**

Bestell-Nr.	Form	l	e	e <sub>1</sub>	Anzahl Schrauben
2965.81.060.047.0150	B	150	30	-	2
0200	C	200	25	-	2
0250	A	250	25	80	3
0300	A	300	30	100	3

**Bestell-Beispiel:**

Einseiten-Prismenführung = 2965.81.  
 Breite = 60 mm = 060.  
 Dicke = 47 mm = 047.  
 l = 250 mm = 0250  
 Bestell-Nummer = 2965.81.060.047.0250

**GLISSIÈRES EN ACIER**

Art. 2965.83

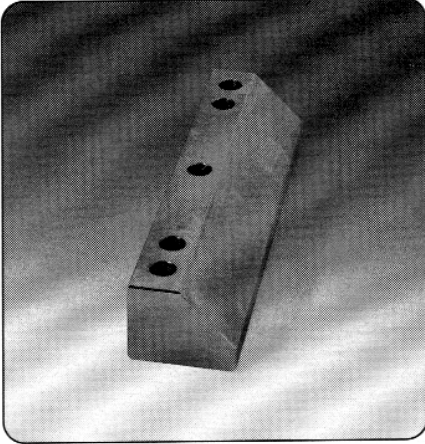
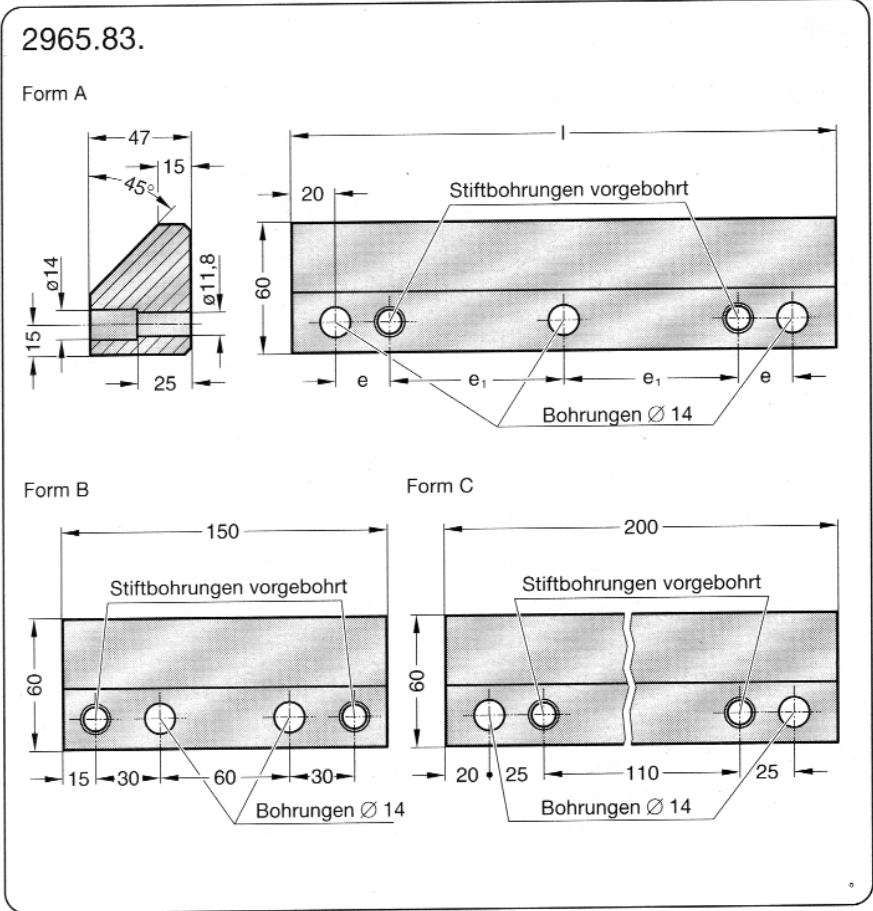

**Werkstoff:**  
 Stahl  
 Gleitflächen oberflächengehärtet.

**Hinweis:**  
 Einseiten-Prismenführungen 2965.81. siehe gegenüberliegende Seite  
 Lieferung ohne Schrauben und Stifte.

2965.83.

Bestell-Nr.	Form	l	e	e <sub>1</sub>	Anzahl Schrauben
2965.83.060.047.0150	B	150	30	-	2
0200	C	200	25	-	2
0250	A	250	25	80	3
0300	A	300	30	100	3

Blank area for notes or additional information.

**Bestell-Beispiel:**  
 Einseiten-Prismen-Gleitstücke = 2965.83.  
 Breite = 60 mm = 060.  
 Dicke = 47 mm = 047.  
 l = 250 mm = 0250  
 Bestell-Nummer = 2965.83.060.047.0250



**GLISSIÈRES**

**Art. 2965.80**

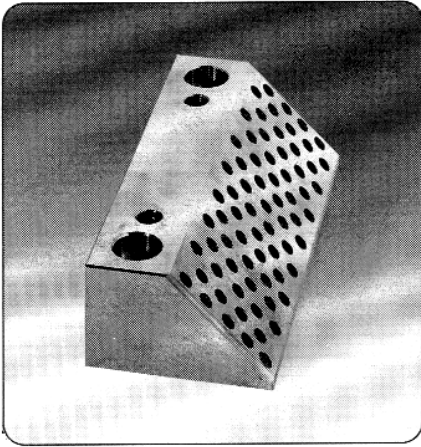

2965.80.

Form A

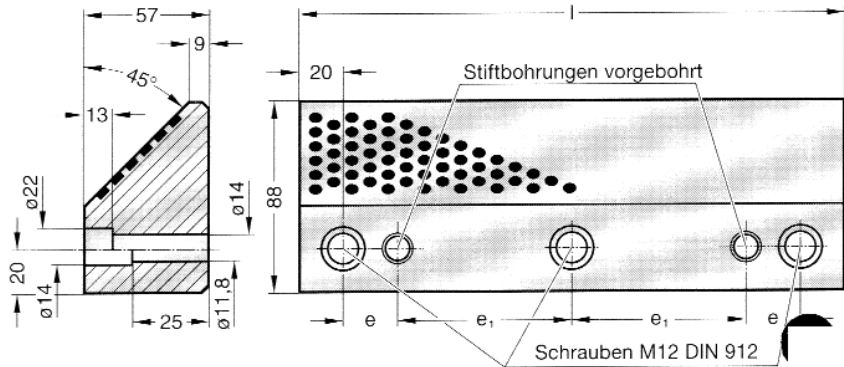

Form B

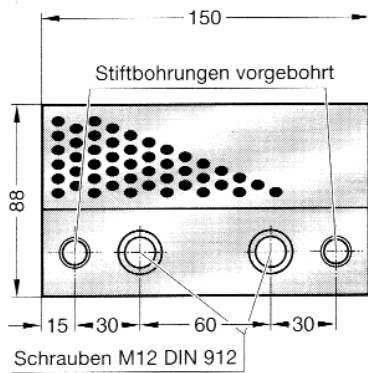

Form C

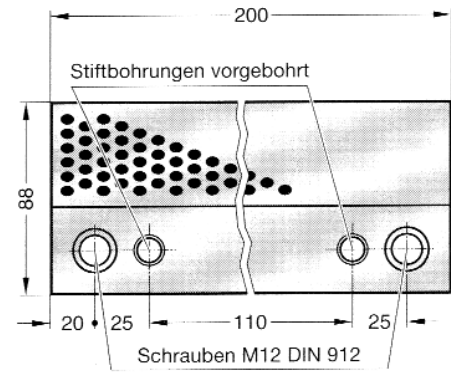

**Werkstoff:**

Bronze mit Festschmierstoff, wartungsarm.

**Hinweis:**

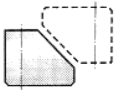

Einseiten-Prismen-Gleitstücke 2965.82. siehe gegenüberliegende Seite

Lieferung ohne Schrauben und Stifte.

2965.80.

Bestell-Nr.	Form	l	e	e <sub>1</sub>	Anzahl Schrauben
2965.80.088.057.0150	B	150	30	-	2
0200	C	200	25	-	2
0250	A	250	25	80	3
0300	A	300	30	100	3

**Bestell-Beispiel:**

Einseiten-Prismenführung = 2965.80.  
 Breite = 88 mm = 088.  
 Dicke = 57 mm = 057.  
 l = 250 mm = 0250  
 Bestell-Nummer = 2965.80.088.057.0250

**PATINS EN ACIER**

Art. 2965.82

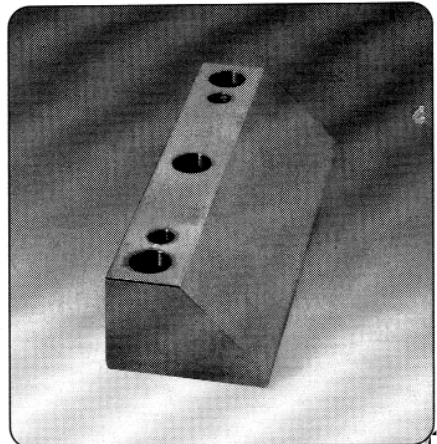
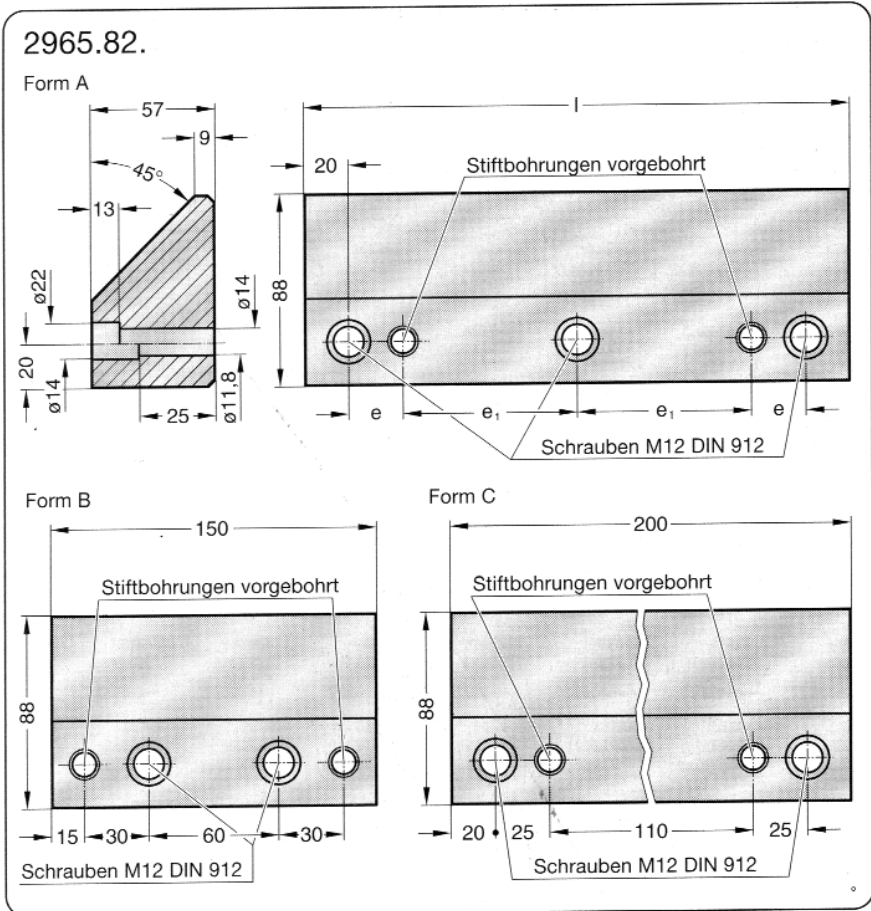

**Werkstoff:**

Stahl  
Gleitflächen oberflächengehärtet.

**Hinweis:**

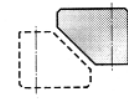

Einseiten-Prismenführungen 2965.80. siehe gegenüberliegende Seite

Lieferung ohne Schrauben und Stifte.

2965.82.

Bestell-Nr.	Form	l	e	e <sub>1</sub>	Anzahl Schrauben
2965.82.088.057.0150	B	150	30	-	2
0200	C	200	25	-	2
0250	A	250	25	80	3
0300	A	300	30	100	3

**Bestell-Beispiel:**

Einseiten-Prismen-Gleitstück = 2965.82.  
 Breite = 88 mm = 088.  
 Dicke = 57 mm = 057.  
 l = 250 mm = 0250  
 Bestell-Nummer = 2965.82.088.057.0250