

## BRIDE HORIZONTALE POUR MACHOIRE INTERCHANGEABLE

**H.23190**

**MATIERE ET EXECUTION :**

Ref. H.23190.0050 à 0055 = bride en acier traité, bruni.

 Ref. H.23190.0060 à 0065 = mâchoire en laiton,  
température d'utilisation jusqu'à 250°C.

 Ref. H.23190.0070 à 0075 = mâchoire en plastique,  
température d'utilisation jusqu'à 80° C.

**REMARQUE :** pour le bridage de pièces fragiles.  
Les mâchoires sont fixées par 2 vis à tête fraisée.

**BRIDE SEULE**

b1 + 0,5	l1	b2	b3	d1	d2	e1	e2	h1	l2	l3	l4	s	Ref.
5,5	40	12	6	M6	M2	8	15,5	8	6	3	4	3	H.23190.0050
7,0	50	16	9	M6	M2,5	10	22	10	8	4	5	4	H.23190.0051
9,0	63	20	11	M8	M3	12	29	12	10	5	6	4	H.23190.0052
11,0	80	25	14	M10	M4	15	36	16	13	6,5	8	6	H.23190.0053
14,0	100	32	16	M12	M5	18	44	20	16	8	10	8	H.23190.0054
18,0	160	50	30	M16	M8	30	13	30	28	14	16	12	H.23190.0055

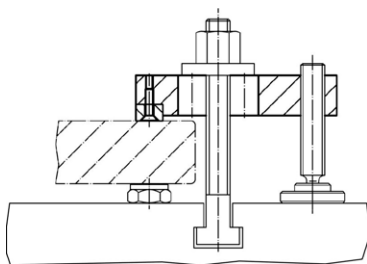
**MACHOIRE**

b1 + 0,5	b4	d2	h2	h3	l5	l6	SW	Ref.	
								laiton	plastic
5,5	6	M2	4	8	12	6	1,3	H.23190.0060	H.23190.0070
7,0	8	M2,5	6	10	16	9	1,5	H.23190.0061	H.23190.0071
9,0	10	M3	6	12	20	11	2,0	H.23190.0062	H.23190.0072
11,0	13	M4	9	16	25	14	2,5	H.23190.0063	H.23190.0073
14,0	16	M5	12	20	32	16	3,0	H.23190.0064	H.23190.0074
18,0	28	M8	16	30	50	30	5,0	H.23190.0065	H.23190.0075

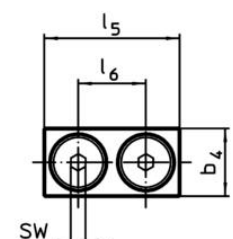
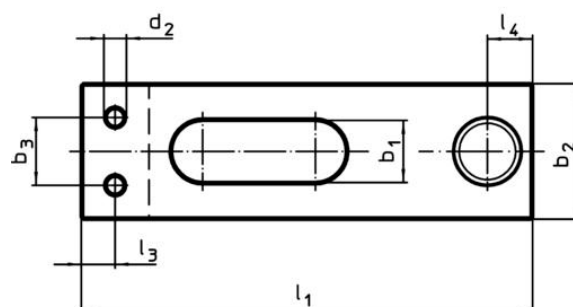
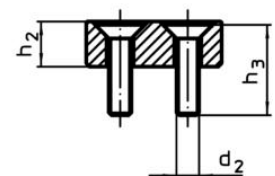
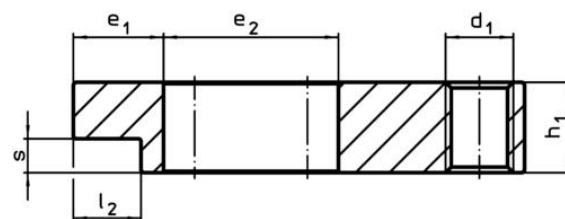

croquis 1

croquis 2

## BRIDE PLATE A BILLE PENDULAIRE TRONQUEE

H.23180

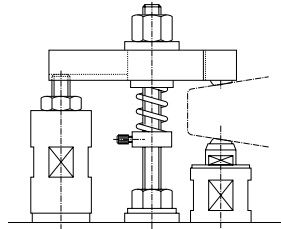

**MATIERE** : acier traité.

**EXECUTION** : bride brunie, la bille en acier est bloquée pour éviter le retournement.

**REMARQUE** : autres dim. suivant DIN 6314.

b1	l1	Ø d3	a3	h	l2	Ø bille	Ref.
6,6	50	5,5	2,5	1,6	5	8,5	H.23180.0007
9	60	7,2	3	2	6,5	10	H.23180.0009
11	80	8,6	3,5	2,7	7,5	12	H.23180.0011
13	125	10,5	4	3,5	10,5	16	H.23180.0014

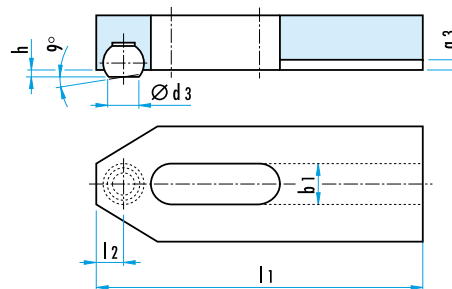

## BRIDE PLATE A NEZ

H.23180

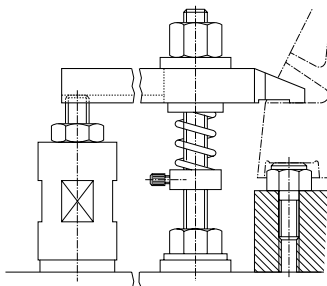

**MATIERE** : acier traité.

**EXECUTION** : bruni.

G = avec filet pour vis de réglage,

N = avec rainure.

b1	l1	a1	a2	a3	b2	b3	d	l2	l3	l4	l5	couple max Nm	Ref.	
													G	N
6,6	80	8	2,5	2,5	15	7,5	M6	17	23	13	34	5	H.23180.0107	.0207
9	100	12	4	3	20	9,5	M8	22	29	17	42	12	H.23180.0109	.0209
11	125	15	5	3,5	25	11,5	M10	28	36	21	52	30	H.23180.0111	.0211
13	150	20	7	4	30	13,5	M12	34	43	25	63	55	H.23180.0113	.0213
17	175	25	9	4,5	35	15,5	M16	40	52	29	70	80	H.23180.0117	.0217

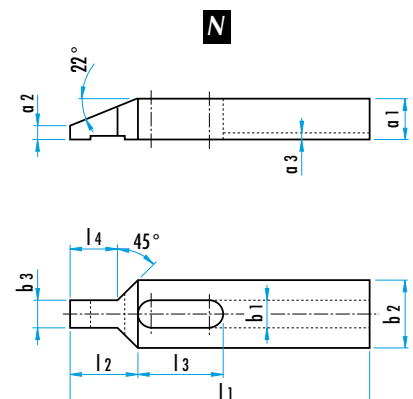
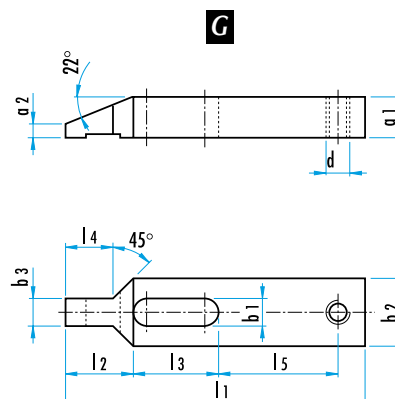

## BRIDE FERMEE A NEZ

H.2317



MATIERE : acier traité, peint.

REMARQUE :

La forme fermée de cette bride est intéressante pour des pièces tournantes.

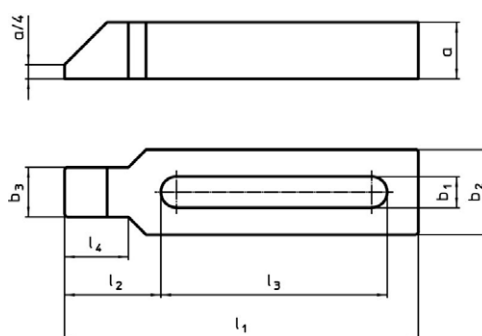
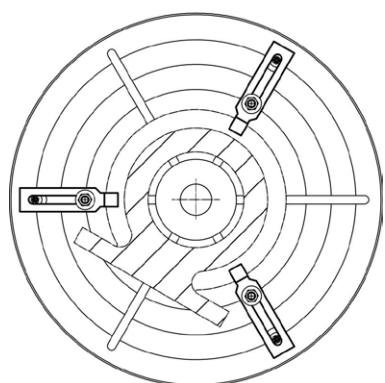

b1	l1	a	b2	b3	l2	l3	l4	pour vis	poids (kg)	Ref.
22	250	40	60	35	68	160	45	M20 / M22 / 3/4"	2,93	H.23170.0022
22	315	40	60	35	68	220	45	M20 / M22 / 3/4"	3,75	H.23170.0023
26	250	40	70	43	83	140	56	M24 / 1"	3,52	H.23170.0026
26	315	40	70	43	83	200	56	M24 / 1"	4,51	H.23170.0027
26	500	50	70	43	83	370	56	M24 / 1"	7,60	H.23170.0029
33	315	50	80	50	88	200	56	M30 / 1 <sup>1</sup> / <sub>4</sub> "	6,37	H.23170.0030
33	400	50	80	50	88	283	56	M30 1 <sup>1</sup> / <sub>4</sub> "	7,78	H.23170.0031

## BRIDE COUDEE DOUBLE

D6317

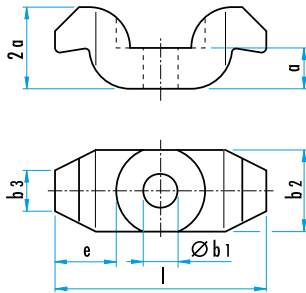

**MATIERE** : acier traité.  
**EXECUTION** : peint.

Ø b1	l	pour	a	b2	b3	e	poids (g)	Ref.
18	100	M12 / M18	20	40	20	26	620	D6317.18.100
25	140	M20 / M24	30	60	30	38	2040	D6317.25.140

## BRIDE COURTE

EPY.SP

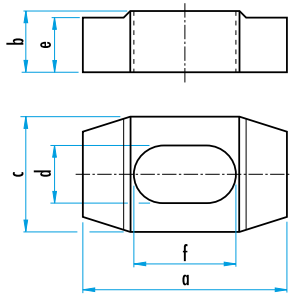

**MATIERE** : acier traité.  
**EXECUTION** : usiné.

d	a	Cotes (mm)				Ref.
		b	c	e	f	
13	56	16	28	11	26	EPY.SP.5003
17	60	18	38	16	30	EPY.SP.5001

## BRIDE ETAGEE

H.23160

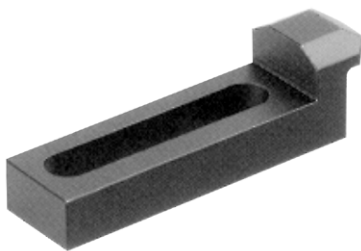

**MATIERE** : acier traité, bruni.

b1	l1	a	b2	b3	c	e1	e2	e3	h	h1	h2	pour vis	Ref.
6,6	55	8	15	8	5	11	15,5	36	16	11	2	M6	H.23160.0107
9	70	10	20	10	8	15	19,5	46	20	14	3	M8	H.23160.0109
11	90	13	25	12	10	19	26,5	58	25	18	4	M10	H.23160.0111
13	115	16	30	15	12	24	32,5	75	32	23	5	M12	H.23160.0113
17	145	20	40	20	14	29	38,5	99	40	28	6	M16	H.23160.0117

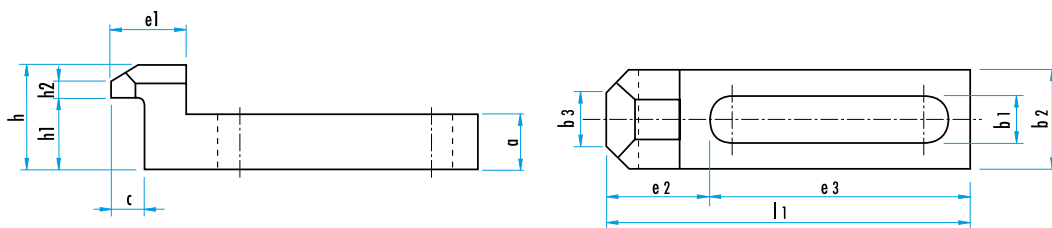

## BRIDE PLATE

H.23210

MATIERE : acier trempé

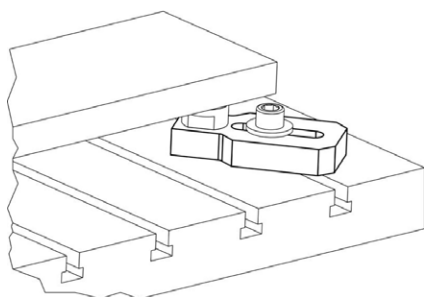
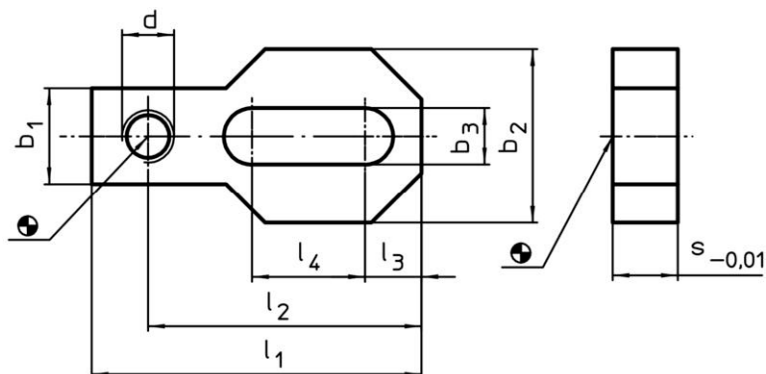

d	l1	l2	l3	l4	b1	b2	b3	s -0,01	poids (g)	Ref.
M20	180	150	30	80	60	90	21	30	2770	H.23210.0870
M24	220	188	35	100	70	100	25	30	3770	H.23210.0880