

## ZESKANTE MOER - M = 1,5 d1 DIN 6330 B

H.23070

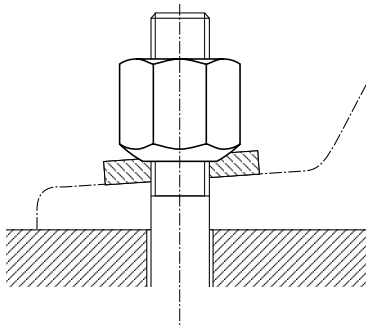

**MATERIAAL** : thermisch behandeld staal.

**UITVOERING** : kwaliteit 10 - zwRef.

B : met bolvormig draagvlak aan één uiteinde.

**OPMERKING** : het bolvormig draagvlak stemt overeen met het hol rondsel DIN 6319.

Door deze combinatie worden afwijkingen bij het positioneren automatisch opgevangen.

Ø d1	Ø d2	e	m	r	s	Ref.
M6	7	11,5	9	9	10	H.23070.0006
M8	9	15	12	11	13	H.23070.0008
M10	11,5	18,5	15	15	16	H.23070.0010
M12	14	20,8	18	17	18	H.23070.0012
M14	16	24,2	21	20	21	H.23070.0014
M16	18	27,7	24	22	24	H.23070.0016
M18	20	31,2	27	24,5	27	H.23070.0018
M20	22	34,6	30	27	30	H.23070.0020
M22	24	39,3	33	29	34	H.23070.0022
M24	26	41,6	36	32	36	H.23070.0024
M30	32	53,1	45	41	46	H.23070.0030
M36	38	63,5	54	50	55	H.23070.0036

**MATERIAAL** : RVS 1.4305



Ø d1	Ø d2	e	m	r	s	Ref.
M8	9	15	12	11	13	H.23070.0108
M10	11,5	18,5	15	15	17	H.23070.0110
M12	14	20,8	18	17	19	H.23070.0112
M16	18	27,7	24	22	24	H.23070.0116
M20	22	34,6	30	27	30	H.23070.0120

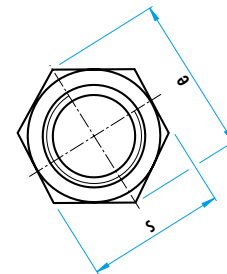
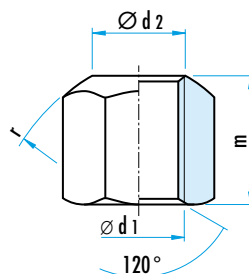

## ZESKANTE MOER MET KRAAG m = 1,5 d1 - DIN 6331

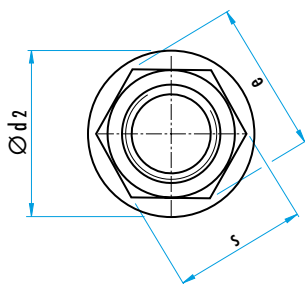
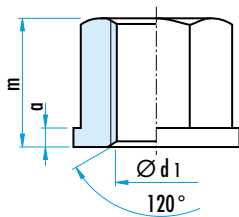
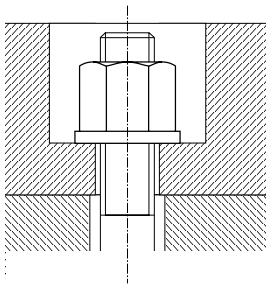
**H.23080**

**MATERIAAL** : thermisch behandeld staal.

**UITVOERING** : kwaliteit 10 - zwRef.

Op aanvraag : • M4 / 42 / 48,

• fijne schroefdraad,

• Engelse en VS maten : Ref. WWN.404

Ø d1	a	Ø d2	e	m	s	Ref.
M6	3,0	14	11,5	9	10	H.23080.0006
M8	3,5	18	15	12	13	H.23080.0008
M10	4	22	18,5	15	16	H.23080.0010
M12	4	25	20,8	18	18	H.23080.0012
M14	4,5	28	24,2	21	21	H.23080.0014
M16	5	31	27,7	24	24	H.23080.0016
M18	5,5	34	31,2	27	27	H.23080.0018
M20	6	37	34,6	30	30	H.23080.0020
M22	6	40	39,3	33	34	H.23080.0022
M24	6	45	41,6	36	36	H.23080.0024
M30	8	58	53,1	45	46	H.23080.0030
M36	10	68	63,5	54	55	H.23080.0036

**MATERIAAL** : RVS 1.4305.

Op aanvraag : M5 / 6 : Ref. WWN.805



Ø d1	a	Ø d2	e	m	s	Ref.
M8	3,5	18	15	12	13	H.23080.0108
M10	4	22	18,5	15	16	H.23080.0110
M12	4	25	20,8	18	18	H.23080.0112
M16	5	31	27,7	24	24	H.23080.0116
M20	6	37	34,6	30	30	H.23080.0120

RVS 1.4305 - AISI 303 (Ref. WWN.8905)

RVS 1.4401 - AISI 316 (Ref. WWN.805)

## ZESKANTE VERLENGDE MOER m = 3 d1 - DIN 6334

H.23090

**MATERIAAL** : thermisch behandeld staal.

**UITVOERING** : kwaliteit 10 - zwRef.

Op aanvraag : • RVS, (WWN.832 - M8 / 10 / 12).

• "inch" afmetingen ( WWN.635)

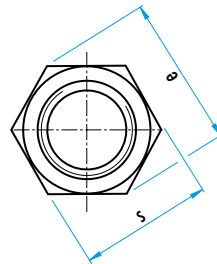
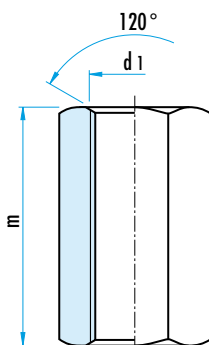
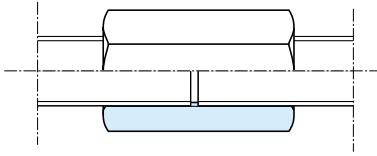

Ø d1	e	m	s	Ref.
M6	11,5	18	10	H.23090.0006
M8	15	24	13	H.23090.0008
M10	18,5	30	16	H.23090.0010
M12	20,8	36	18	H.23090.0012
M14	24,2	42	21	H.23090.0014
M16	27,7	48	24	H.23090.0016
M20	34,6	60	30	H.23090.0020
M24	41,6	72	36	H.23090.0024
M30	53,1	90	46	H.23090.0030
M36	63,5	108	55	H.23090.0036

## ZESKANTE MOER MET KOGELZITTING

H.23080

**MATERIAAL** : staal.

**UITVOERING** : thermisch behandeld en gebruind.

Op aanvraag : • M4 / 5 / 6,

• Engelse en VS maten : Ref. WWN.408



d1	d2	m	s	Ref.
M8	17	14	13	H.23080.0508
M10	21	17,5	16	H.23080.0510
M12	24	21,5	18	H.23080.0512
M16	30	28	24	H.23080.0516
M20	36	35	30	H.23080.0520
M24	44	42,5	36	H.23080.0524
M30	55	56	46	H.23080.0530

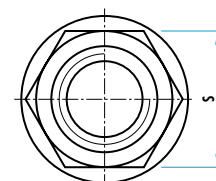
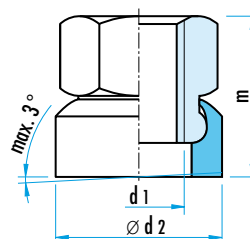
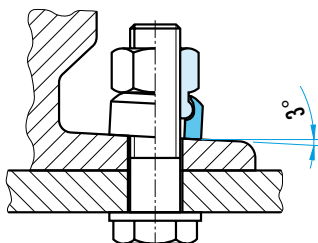

## ZESKANTE MOER MET INGEBOUWD RONDSEL

KWN.7242



**MATERIAAL** : thermisch behandeld staal, gebruind, zeskante moer en rondsel  
kwaliteit 10, steuning uit PA 6, blauw.

**OPMERKING** : compacte eenheid; het rondsel is door de steuning onverliesbaar  
en met de zeskante moer verbonden; plaatsbesparing in vergelijking met andere systemen  
zoals spanschijven, flenzen, speciale klauwen...

D	M	A	A1	A2	Ø D1	Ø D2	Ø D3	E	SW	Ref.
M8	15,5	7	3,5	6	17	18,6	8,5	15	13	KWN.7242.08
M10	19	8	4	7	21	22,7	10,5	18,5	17	KWN.7242.10
M12	22	8	4	7	24	25,7	12,5	20,8	19	KWN.7242.12
M16	29	10	5	9	30	32	16,5	27,7	24	KWN.7242.16
M20	36	12	6	11	36	38	20,5	34,6	30	KWN.7242.20
M24	42	12	6	11	44	46	24,5	41,6	36	KWN.7242.24

