

SPANEENHEID MET NOK

K.0010 - K.0011



MATERIAAL : excenter uit thermisch behandeld staal 34 Cr Mo 4, gebruind, spanplaat uit staal Ck 35, gebruind.

UITVOERING : Ref. K.0010 : met spannen op het uiteinde, Ref. K.0011 : met spannen in het midden.

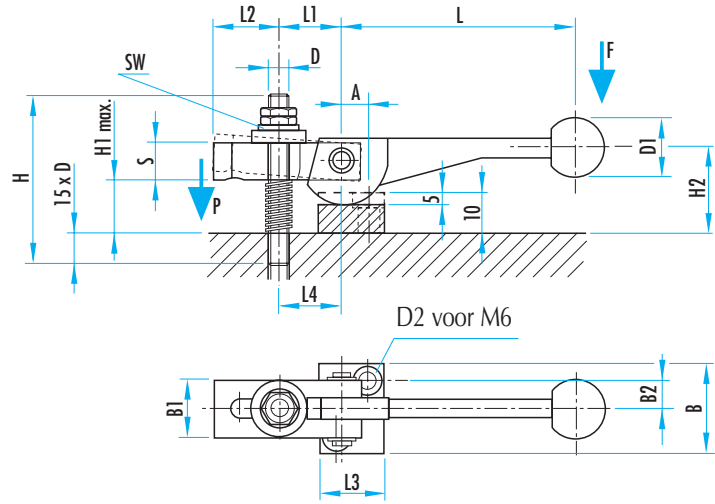
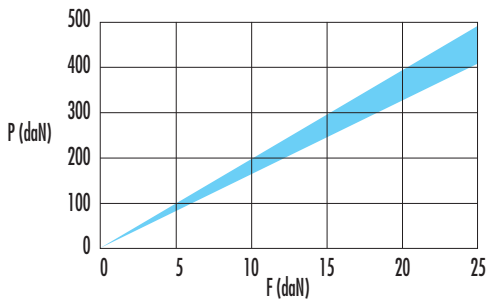

K.0010

L	L1	L2	L3	L4	B	B1	B2	S	H	H1max.	H2	D	D1	D2	A	SW	Ref.
100	27	28	28	27	38	25	12	16	70	25	34	M8	25	7	14	13	K.0010.08
120	34	36	32	35	41	32	13,5	20	80	24	40	M10	32	7	16	17	K.0010.10
138,5	43	45	37	45	43	40	14,5	25	100	31	48	M12	32	7	19	19	K.0010.12

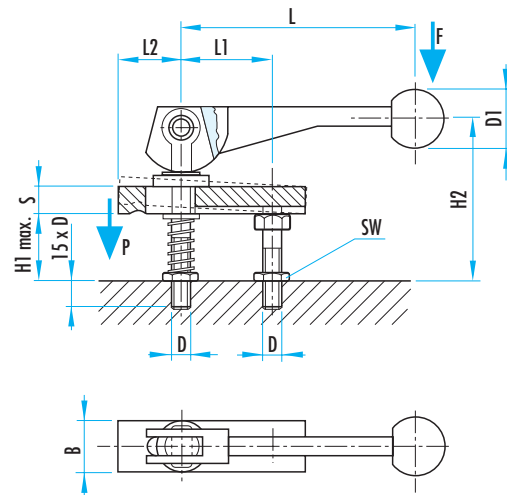
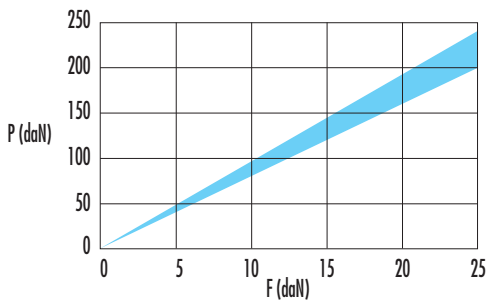
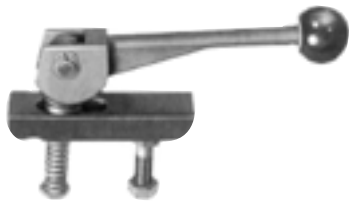

K.0011

L	L1	L2	B	S	H1max.	H2	D	D1	SW	Ref.
100	39	37	20	12	28	74	M8	25	13	K.0011.08
120	49	46	25	16	39	92	M10	32	17	K.0011.10
138,5	61	58	32	25	49	120	M12	32	19	K.0011.12