

## PENDELSCHOTEL

**H.22590**

"Staal"

**MATERIAAL EN UITVOERING :**

Ref. H.22590.00... : voet en kogelelement uit staal, gebruid..

Ref. H.22590.01... : voet uit witte thermoplast (POM) en kogelelement uit RVS 1.4305.

Ref. H.22590.02... : voet en kogelelement uit RVS 1.4305.

**OPMERKING :**

Wordt gebruikt als voet of drukstuk.

Gebruikstemperatuur voor thermoplast uitvoering : max. 80°C.

| d1  | d2 | ~ h1 | h2  | t    | SW | Statische last max. (kN) |     | Gewicht (g) | Ref.         |              |
|-----|----|------|-----|------|----|--------------------------|-----|-------------|--------------|--------------|
|     |    |      |     |      |    | Staal                    | RVS |             | Staal        | RVS          |
| M6  | 20 | 14   | 2,5 | 5,0  | 10 | 10                       | 8   | 15          | H.22590.0006 | H.22590.0206 |
| M8  | 25 | 18   | 4,0 | 7,0  | 13 | 18                       | 14  | 33          | H.22590.0008 | H.22590.0208 |
| M10 | 32 | 22   | 5,0 | 9,0  | 17 | 20                       | 16  | 66          | H.22590.0010 | H.22590.0210 |
| M12 | 40 | 26   | 6,0 | 11,0 | 19 | 35                       | 28  | 112         | H.22590.0012 | H.22590.0212 |
| M16 | 50 | 32   | 7,0 | 13,5 | 24 | 45                       | 36  | 220         | H.22590.0016 | H.22590.0216 |
| M20 | 60 | 42   | 8,0 | 17,0 | 30 | 55                       | 44  | 413         | H.22590.0020 | H.22590.0220 |
| M24 | 60 | 45   | 9,5 | 19,0 | 36 | 65                       | 52  | 462         | H.22590.0024 | H.22590.0224 |



| d1  | d2 | ~ h1 | h2  | t    | SW | Statische last max. (kN) | Gewicht (g) | Ref. "POM"   |
|-----|----|------|-----|------|----|--------------------------|-------------|--------------|
| M6  | 20 | 14   | 2,5 | 5,0  | 10 | 4                        | 6           | H.22590.0106 |
| M8  | 25 | 18   | 4,0 | 7,0  | 13 | 7                        | 13          | H.22590.0108 |
| M10 | 32 | 22   | 5,0 | 9,0  | 17 | 10                       | 26          | H.22590.0110 |
| M12 | 40 | 26   | 6,0 | 11,0 | 19 | 18                       | 40          | H.22590.0112 |
| M16 | 50 | 32   | 7,0 | 13,5 | 24 | 20                       | 75          | H.22590.0116 |
| M20 | 60 | 42   | 8,0 | 17,0 | 30 | 22                       | 150         | H.22590.0120 |
| M24 | 60 | 45   | 9,5 | 19,0 | 36 | 25                       | 184         | H.22590.0124 |

"RVS"



"POM"

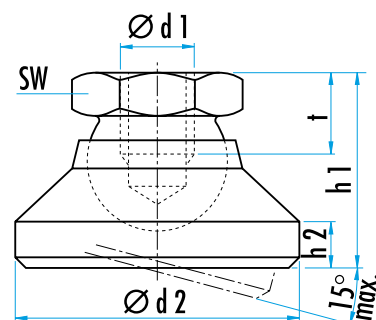

## SCHARNIERVOET

**K.0304**

**MATERIAAL EN UITVOERING :**

Kogel uit gehard staal, lichaam uit gebruid staal.

**OPMERKING :**

Gebruik slechts voor drukbelasting.

Op aanvraag : duimmaten.

| D   | D1 | H    | H1  | H2  | SW | max. kracht (daN) | gewicht (g) | Ref.      |
|-----|----|------|-----|-----|----|-------------------|-------------|-----------|
| M5  | 13 | 16,5 | 6,5 | 4   | 10 | 162               | 12          | K.0304.05 |
| M6  | 13 | 16,5 | 8,5 | 4   | 10 | 233               | 11          | K.0304.06 |
| M8  | 16 | 21   | 9   | 4   | 13 | 415               | 23          | K.0304.08 |
| M10 | 19 | 23   | 10  | 4   | 17 | 648               | 35          | K.0304.10 |
| M12 | 22 | 25,5 | 12  | 4,7 | 19 | 832               | 52          | K.0304.12 |
| M16 | 25 | 29,5 | 14  | 5   | 24 | 1394              | 74          | K.0304.16 |
| M20 | 32 | 36   | 18  | 8,5 | 30 | 2100              | 138         | K.0304.20 |

