

AFNEEMBARE POSITIONEERSTIFT

Art. WVN.507/509



Art. WVN.507

MATERIAAL : decolleteerstaal.

UITVOERING : gehard, geslepen en gebruid. Art. WVN.507 : zonder dwarsstift, Art. WVN.509 : met dwarsstift.

Met kraag voor ketting, zie hieronder.

Op aanvraag : duim afmetingen 1/8" tot 1/2".

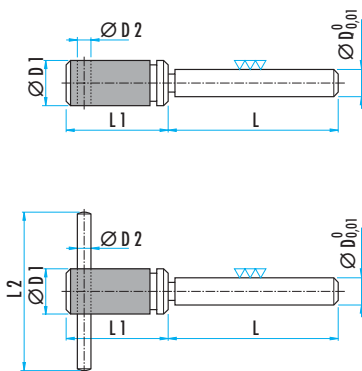

Art. WVN.509

ØD	L	ØD1	ØD2	L1	L2	g	ketting	Art. WVN.507	Art. WVN.509
3	20	10	5	32	45	20	510-201	2003.20	2003.20
	40					2003.40		2003.40	
4	20	10	5	32	45	20	510-201	2004.20	2004.20
	40					2004.40		2004.40	
5	35	10	5	32	45	25	510-201	201.35	201.35
	50					201.50		201.50	
6	35	13	5	40	65	50	510-202	202.35	202.35
	75					202.75		202.75	
8	35	13	6	40	70	50	510-202	203.35	203.35
	75					203.75		203.75	
10	50	16	6	40	70	90	510-203	204.50	204.50
	100					204.100		204.100	
12	75	20	6	45	70	165	510-204	205.75	205.75
	125					205.125		205.125	

KETTING MET RING

Art. WVN.510.

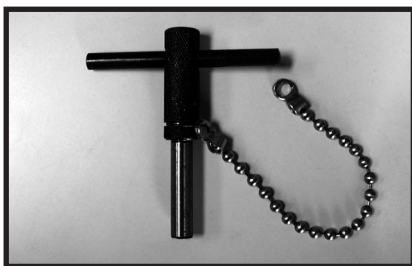

MATERIAAL EN UITVOERING : ring uit gehard bandstaal; kogelketting uit messingkogels. Gebruik met positioneerstift Ø D 8,5 tot 17,5, Art. WVN.507/509 (zie hierboven).

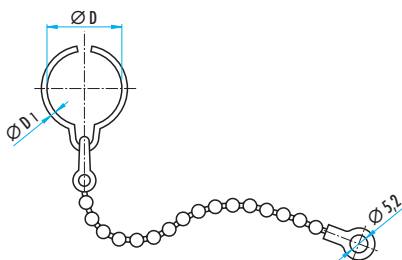

ØD	L	ØD1	g	Art. WVN.510...
8,5	150	0,9	8	201.150
	300		14	201.300
	500		22	201.500
11,5	150	1,2	8	202.150
	300		14	202.300
	500		22	202.500
14,5	150	1,6	8	203.150
	300		14	203.300
	500		22	203.500
17,5	150	1,6	9	204.150
	300		15	204.300
	500		22	204.500

ØD	L	ØD1	g	Art. WDS.510...
20,5	150	2	9	205.150
	300		16	205.300
	500		22	205.500
23,5	150	2	9	206.150
	300		16	206.300
	500		22	206.500
29,5	150	2,6	13	207.150
	300		18	207.300
	500		26	207.500
35,5	150	2,6	13	208.150
	300		19	208.300
	500		29	208.500