

SPIEAS ISO 14 - DIN 5463

FCC.AS / ASX



MATERIAAL EN UITVOERING :

Staal C 40 of RVS 1.4301 (AISI 304)

Lengte : 1.000 mm.

Combineerbaar met spiebus Ref. FCC.BB



Ø D	Ø d	c	Z	Sectie mm ²	Sm. 45°	r	Ref.	
							STAAL	RVS
14	11	3	6	121,9	0,2	0,2	FCC.AS.11.14	FCC.ASX.11.14
16	13	3,5	6	164,1	0,2	0,2	FCC.AS.13.16	FCC.ASX.13.16
20	16	4	6	243,4	0,2	0,2	FCC.AS.16.20	FCC.ASX.16.20
22	18	5	6	312,4	0,2	0,2	FCC.AS.18.22	-
25	21	5	6	399,8	0,2	0,2	FCC.AS.21.25	FCC.ASX.21.25
28	23	6	6	505,2	0,3	0,2	FCC.AS.23.28	-
32	26	6	6	638,6	0,3	0,3	FCC.AS.26.32	FCC.ASX.26.32
38	32	6	8	947,8	0,3	0,3	FCC.AS.32.38	FCC.ASX.32.38
42	36	7	8	1185,3	0,3	0,3	FCC.AS.36.42	-
48	42	8	8	1576,7	0,3	0,3	FCC.AS.42.48	-
54	46	9	8	1949	0,5	0,5	FCC.AS.46.54	-

Z = aantal spiebanen

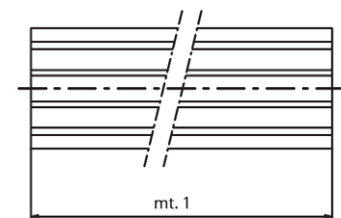
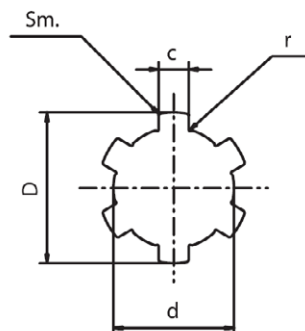

SPIEAS OP MAAT

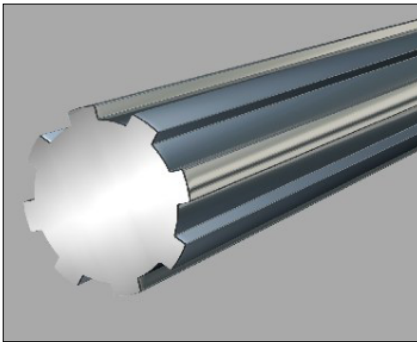
D5463.KW

MATERIAAL EN UITVOERING :

Staal C 45 (genitreerd op aanvraag tot een lengte van 700 mm)

Lengte naar keuze – max. 6.000 mm.

Combineerbaar met :

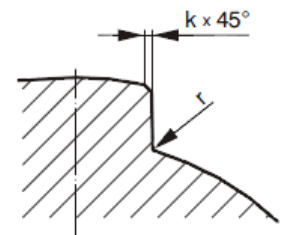
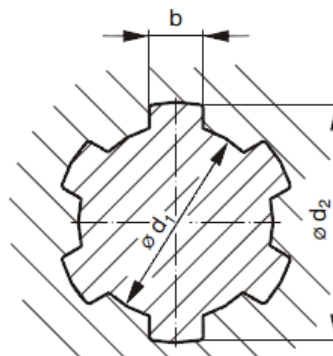
- spiebus Ref. D5463.KN...
- flensspiebus Ref. D5463.KF...
- klemring Ref. D5463.KR...



Ø d	Ø D	Z	c	r	Sm. 45°	Sectie mm²	Ref. (1m)	
							STAAL	RVS
11	14	6	3	0,2	0,2	121,9	D5463.KW.11.14	D5463.KW.11.14.R
13	16	6	3,5	0,2	0,2	164,1	D5463.KW.13.16	D5463.KW.13.16.R
16	20	6	4	0,2	0,2	243,4	D5463.KW.16.20	D5463.KW.16.20.R
18	22	6	5	0,2	0,2	312,4	D5463.KW.18.22	-
21	25	6	5	0,2	0,2	399,8	D5463.KW.21.25	D5463.KW.21.25.R
23	28	6	6	0,2	0,3	505,2	D5463.KW.23.28	-
26	32	6	6	0,3	0,3	638,6	D5463.KW.26.32	D5463.KW.26.32.R
28	34	6	7	0,3	0,3	741,4	D5463.KW.28.34	-
32	38	8	6	0,3	0,3	947,8	D5463.KW.32.38	-
36	42	8	7	0,3	0,3	1185,3	D5463.KW.36.42	-
42	48	8	8	0,3	0,3	1576,7	D5463.KW.42.48	-
46	54	8	9	0,5	0,5	1949	D5463.KW.46.54	D5463.KW.46.54

Z = aantal spiebanen

EENVOUDIGE SPIEBUS ISO 14 - DIN 5463

FCC.BB / BBX

MATERIAAL EN UITVOERING :

Staal 9 SMnPb36 of RVS 1.4301 (AISI 304)

Voor radiale en axiale bewegingen.

Combineerbaar met spieas Ref. FCC.SS...



Ø d	Ø D	c	Z	Ø h8	L	Ref.	
						STAAL	RVS
11	14	3	6	18.75	30	FCC.BB.11.14	FCC.BBX.11.14
13	16	3,5	6	21.75	40	FCC.BB.13.16	FCC.BBX13.16
13	16	3,5	6	24.75	FCC.BB.13.16.D	-	
16	20	4	6	27.75	40	FCC.BB.16.20	FCC.BBX.16.20
18	22	5	6	31.75	40	FCC.BB.18.22	-
21	25	5	6	35.75	45	FCC.BB.21.25	FCC.BBX.21.25
23	28	6	6	39.70	45	FCC.BB.23.28	-
26	32	6	6	44.70	45	FCC.BB.26.32	FCC.BBX.26.32
32	38	6	8	49.70	50	FCC.BB.32.38	FCC.BBX.32.38
36	42	7	8	59.70	70	FCC.BB.36.42	-
42	48	8	8	69.70	80	FCC.BB.42.48	-
46	54	9	8	81.70	90	FCC.BB.46.54	-

Z = aantal spiebanen

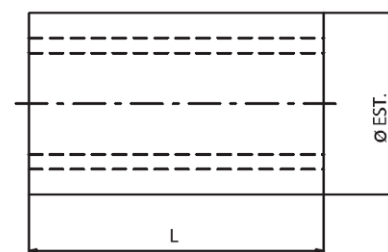
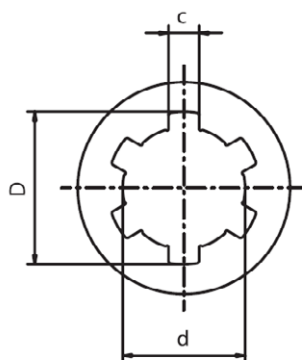
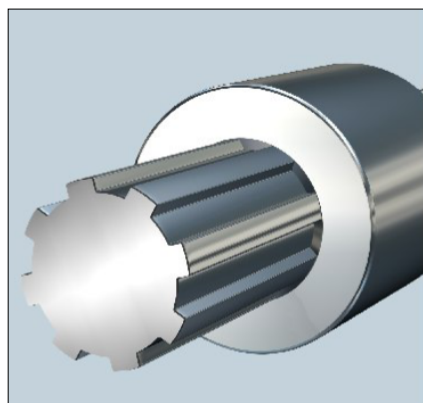

SPIEBUS HOGE WEERSTAND ISO 14 - DIN 5463

D5463.KN



MATERIAAL EN UITVOERING :

Ref. D5463.KNS... = staal C 45 (genitreerd op aanvraag)

Ref. D5463.KNB... = brons Bz 12.

Voor radiale en axiale bewegingen.

Op aanvraag : 52 / 56 / 62 / 72 / 82 mm.

Combineerbaar met spieas Ref. D5463.KW...

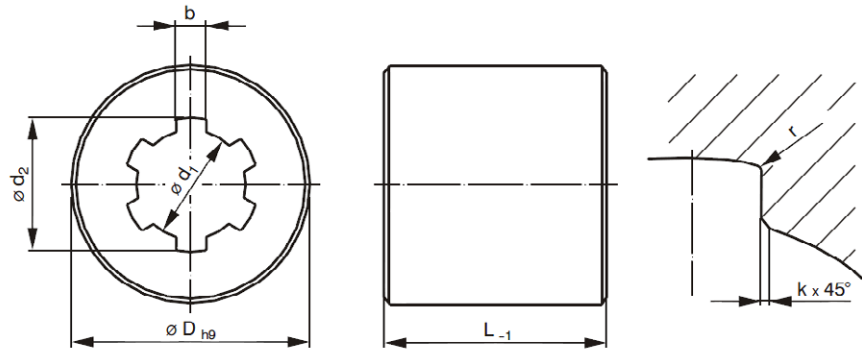

Ø d1	Ø d2	c	Z	Ø D	L	Ref.	
						STAAL	BRONS
11	14	3	6	28	22	D5463.KNS.11.14	D5463.KNB.11.14
13	16	3,5	6	32	26	D5463.KNS.13.16	D5463.KNB.13.16
16	20	4	6	35	32	D5463.KNS.16.20	D5463.KNB.16.20
18	22	5	6	40	36	D5463.KNS.18.22	D5463.KNB.18.22
21	25	5	6	45	42	D5463.KNS.21.25	D5463.KNB.21.25
23	28	6	6	50	46	D5463.KNS.23.28	D5463.KNB.23.28
26	32	6	6	55	52	D5463.KNS.26.32	D5463.KNB.26.32
28	34	7	6	60	56	D5463.KNS.28.34	D5463.KNB.28.34
32	38	6	8	65	64	D5463.KNS.32.38	D5463.KNB.32.38
36	42	7	8	70	72	D5463.KNS.36.42	D5463.KNB.36.42
42	48	8	8	75	80	D5463.KNS.42.48	D5463.KNB.42.48
46	54	9	8	80	90	D5463.KNS.46.54	D5463.KNB.46.54

Z = aantal spiebanen

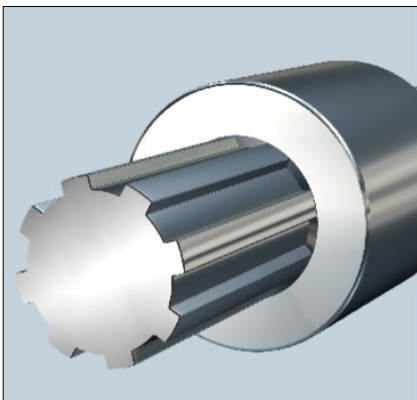

FLENSSPIEBUS ISO 14 - DIN 5463

D5463.KF

MATERIAAL EN UITVOERING :

Ref. D5463.KFS... = staal C 45 (genitreerd op aanvraag)

Ref. D5463.KFB... = brons Bz 12

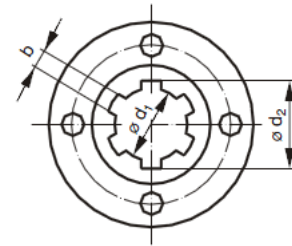
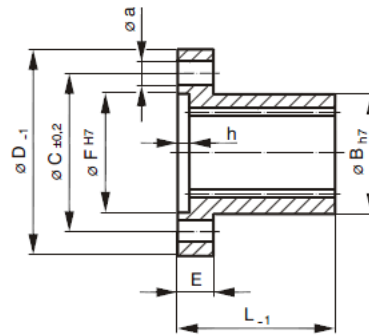

Ø d1	Ø d2	n	b	D	B	C	L	E	F	3	a	Ref.	
												STAAL	BRONS
11	14	6	3	38	20	28	30	8	18	3	4,3	D5463.KFS.11.14	D5463.KFB.11.14
13	16	6	3,5	43	24	32	30	8	20	3	4,3	D5463.KFS.13.16	D5463.KFB.13.16
16	20	6	4	52	28	38	35	9	26	3	5,3	D5463.KFS.16.20	D5463.KFB.16.20
18	22	6	5	54	30	40	40	9	28	3	5,3	D5463.KFS.18.22	D5463.KFB.18.22
21	25	6	5	62	34	48	50	10	35	3,5	6,4	D5463.KFS.21.25	D5463.KFB.21.25
23	28	6	6	64	36	50	55	10	35	3,5	6,4	D5463.KFS.23.28	D5463.KFB.23.28
26	32	6	6	69	42	56	60	10	40	3,5	6,4	D5463.KFS.26.32	D5463.KFB.26.32
28	34	6	7	78	46	60	60	14	45	4	8,4	D5463.KFS.28.34	D5463.KFB.28.34
32	38	8	6	82	50	65	70	14	45	4	8,4	D5463.KFS.32.38	D5463.KFB.32.38
36	42	8	7	90	54	70	80	16	55	4	10,5	D5463.KFS.36.42	D5463.KFB.36.42
42	48	8	8	95	60	75	90	16	60	4	10,5	D5463.KFS.42.48	D5463.KFB.42.48
46	54	8	9	100	65	80	100	16	65	4	10,5	D5463.KFS.46.54	D5463.KFB.46.54

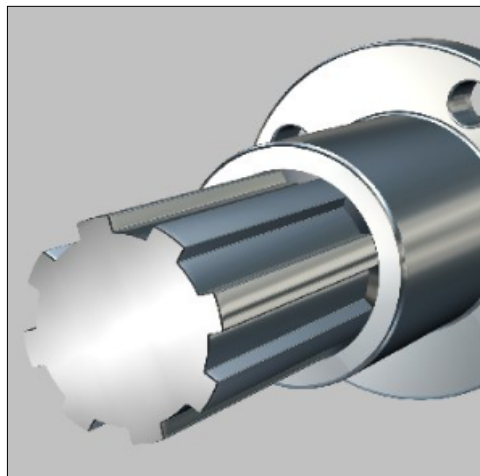

KLEMRING ISO 14 - DIN 5463

D5463.KR

MATERIAAL EN UITVOERING :

Ref. D5463.KRS... = staal C 45 (genitreerd op aanvraag)

Ref. D5463.KRB... = brons Bz 12

Boringen a1 et a2 voor schroef DIN 912 en rondsels DIN 6797.

Zie ontbrekende maten hierboven.

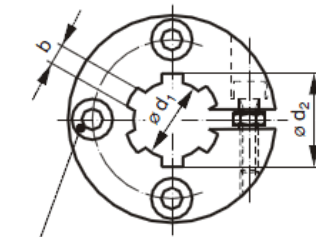
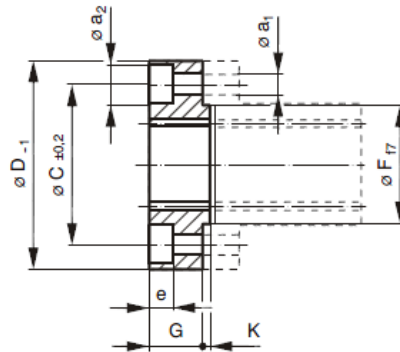

Pour vis à tête cylindrique ISO 4762 (DIN 912)

Ø D (-1)	Ø C (+/-0,2)	Ø F ±7	G	k	e	Ø a1	Ø a2	Ref.	
								STAAL	BRONS
38	28	18	11	2	5	4,3	8	D5463.KRS.11.14	D5463.KRB.11.14
45	32	20	12	2	5	4,3	8	D5463.KRS.13.16	D5463.KRB.13.16
52	38	26	14	2	6	5,3	10	D5463.KRS.16.20	D5463.KRB.16.20
54	40	28	14	2	6	5,3	10	D5463.KRS.18.22	D5463.KRB.18.22
62	48	35	14	3	7	6,4	11	D5463.KRS.21.25	D5463.KRB.21.25
65	50	35	14	3	7	6,4	11	D5463.KRS.23.28	D5463.KRB.23.28
70	56	40	15	3	7	6,4	11	D5463.KRS.26.32	D5463.KRB.26.32
78	60	45	20	3	9	8,4	15	D5463.KRS.28.34	D5463.KRB.28.34
82	65	45	20	3	9	8,4	15	D5463.KRS.32.38	D5463.KRB.32.38
90	70	55	22	3	11	10,5	18	D5463.KRS.36.42	D5463.KRB.36.42
95	75	60	22	3	11	10,5	18	D5463.KRS.42.48	D5463.KRB.42.48
100	80	65	24	3	11	10,5	18	D5463.KRS.46.54	D5463.KRB.46.54

