

**SCHOKDEMPER "MEGA-LINE"  
0,1 - 0,15 - 0,2**

W.E / W.S / W.P

M8 x 1  
M10 x 1  
M12 x 1



**Technische kenmerken :**

Ref. : **W.E** : regelbaar, lineair type.

Ref. : **W.S** : zelf instelbaar, lineair type.

Ref. : **W.P** : zelf instelbaar, progressief type.

Met ingebouwde eindkoersaanslag – maximale veiligheid.

**Gebruikstemperatuur :** - 20° tot + 90°C

**Massieve cilinder :** max. + 400% van de energie,  
max. 50% kostenbesparing per Nm.

**Eigen gewicht :** maat 0,1 : 10 g,  
maat 0,15 : 20 g,  
maat 0,2 : 36 g.

**Impactsnelheid :** Ref. : **W.E** : 0,2 tot 3,5 m/s.

Ref. : **W.S** : 0,2 tot 5,0 m/s.

Ref. : **W.P** : 0,2 tot 5,0 m/s.

**Veersterkte :** maat 0,1 : 2,5 N/min. – 6 N/max.  
maat 0,15 : 3,6 N/min. – 8 N/max.  
maat 0,2 : 3,5 N/min. – 7 N/max.

**Max. spankoppel :** maat 0,1 : 2 Nm,  
maat 0,15 : 6 Nm,  
maat 0,2 : 10 Nm.

**Materiaal :** lichaam uit gebruid staal, zuigerstang  
uit geharde RVS, genitreed met een  
aluminium-titaanlaag.

**Opties :**

lichaam	aanslagkap	moer
GW	Ref.	Ref.
M8 x 1	<b>W.14011</b>	<b>W.14012</b>
M10 x 1	<b>W.15011</b>	<b>W.15012</b>
M12 x 1	<b>W.17011</b>	<b>W.17012</b>

## SCHOKDEMPER "MEGA-LINE" 0,1 - 0,15 - 0,2

W.E / W.S / W.P

M8 x 1  
M10 x 1  
M12 x 1

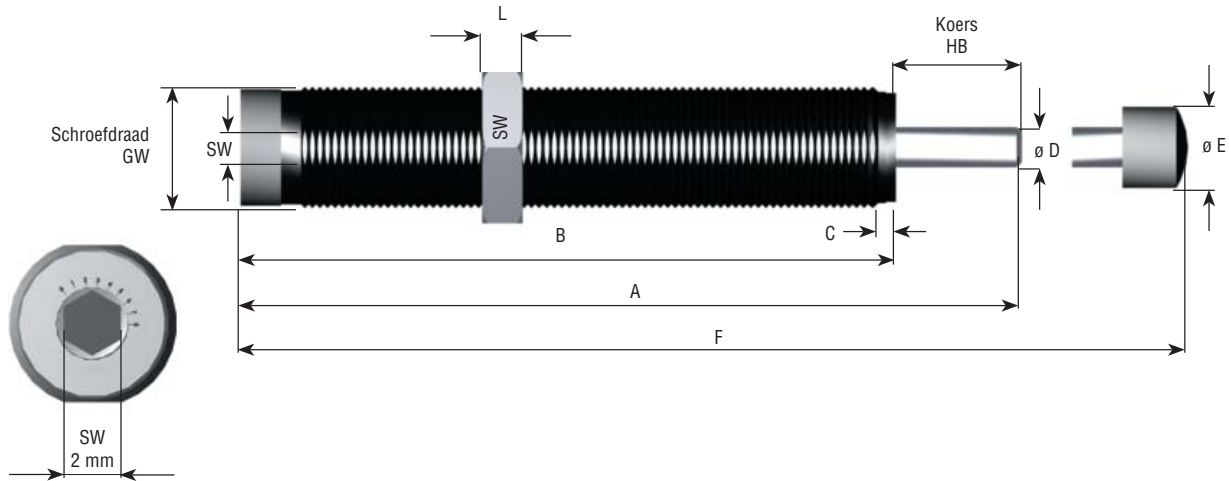

### AFMETINGEN

Ref.	Maat mm	GW mm	A mm	B mm	C mm	ø D mm	ø E mm	F mm	L mm	SW
W.S.204. ...	0,1	M 8 x 1	51	44	2,5	2,5	6	57	3	11
W.P.404. ...	0,1	M 8 x 1	51	44	2,5	2,5	6	57	3	11
W.E.305. ...	0,15	M 10 x 1	59,5	49,5	2,5	3	6	65,5	3	13
W.S.205. ...	0,15	M 10 x 1	59,5	49,5	2,5	3	6	65,5	3	13
W.P.405. ...	0,15	M 10 x 1	59,5	49,5	2,5	3	6	65,5	3	13
W.E.306. ...	0,2	M 12 x 1	77	65	2,5	4	10	83	4	14
W.S.206. ...	0,2	M 12 x 1	77	65	2,5	4	10	83	4	14
W.P.406. ...	0,2	M 12 x 1	77	65	2,5	4	10	83	4	14

### VERMOGEN

	Energie opname				Effectieve massa (kg)			
	HB mm	Constant load*	Emergency**		10 (soft) min.- max.	20 (medium) min.- max.	30 (hard) min.- max.	40 (very hard) min.- max.
		Nm/HB (max.)	Nm/HB (max.)	Nm/h (max.)				
W.S.204.10 / 20 / 30	7	4	6	14.400	0,65 - 2,0	1,3 - 5,5	1,7 - 50	-
W.P.404.10 / 20 / 30	7	4	6	14.400	0,3 - 0,9	0,65 - 2,0	1,8 - 8	-
W.E.305.10	10	15	22,5	24.000	1,0 - 500	-	-	-
W.S.205.10 / 20 / 30 / 40	10	15	22,5	24.000	1,6 - 7,5	6,1 - 71	61 - 252	232 - 750
W.P.405.10 / 20 / 30	10	15	22,5	24.000	1,0 - 2,2	2,0 - 7,5	6,1 - 71	-
W.E.306.10	12	22	33	35.200	9 - 800	-	-	-
W.S.206.10 / 20 / 30 / 40	12	22	33	35.200	2,0 - 11	10 - 107	104 - 360	343 - 1100
W.P.406.10 / 20 / 30	12	22	33	35.200	1,5 - 2,8	2 - 21	17 - 92	-

\*Constante belasting/\*\*Belasting bij noodgeval

### BESTELVOORBEELD

Ref. : W.P.404 - effectieve massa : 1,8 - 8 kg = Ref. : W.P.404.30

**SCHOKDEMPER "MEGA-LINE"  
0,1 - 0,15 - 0,2**

W.E / W.S / W.P

M8 x 1  
M10 x 1  
M12 x 1

**AANSLAGBUS**

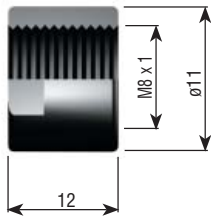

Ref. : W.14018

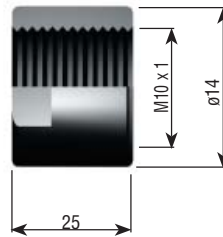

Ref. : W.15018

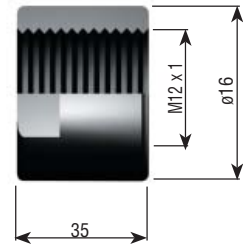

Ref. : W.17018

**RECHTHOEKIGE FLENS**

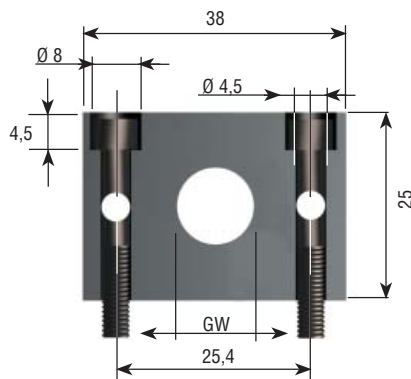

Breedte T = 12 mm

GW = M10 x 1 : Ref. : W.15013

M12 x 1 : Ref. : W.17013

**AK 1 VOOR RADIALE BELASTINGEN 3 TOT 20°**

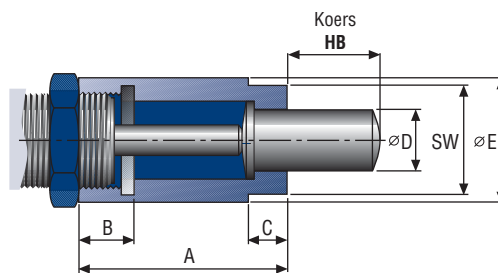

Ref.		A	B	C	ø D	ø E	SW
W.S.20519	M 10 x 1	20,5	7,0	5	7	14	13
W.S.20619	M 12 x 1	23,0	7,0	5	9	15	14

## SCHOKDEMPER "MEGA-LINE" 0,25 - 0,35 - 0,5 - 1,0

W.E / W.S / W.P



M14 x 1 / 1,5  
M16 x 1 / 1,5  
M20 x 1 / 1,5  
M24 x 1,5  
M25 x 1,5  
M27 x 3



### Technische kenmerken :

Ref. : W.E : regelbaar, lineair type.

Ref. : W.S : zelf instelbaar, lineair type.

Ref. : W.P : zelf instelbaar, progressief type.

Met ingebouwde eindkoersaanslag – maximale veiligheid.

**Gebruikstemperatuur :** - 20° tot + 90°C.

**Massieve cilinder :** max. + 400% van de energie,  
max. 50% kostenbesparing per Nm.

**Eigen gewicht :** maat 0,25 : 0,05 kg,  
maat 0,35 : 0,07 kg,  
maat 0,5 : 0,14 kg,  
maat 1,0 : 0,29 kg,  
maat 1,0 x 40 : 0,39 kg.

**Impactsnelheid :** Ref. : W.E : 0,08 tot 6,0 m/s.

Ref. : W.S : 0,08 tot 6,0 m/s.

Ref. : W.P : 0,30 tot 8,0 m/s.

**Veersterkte :** maat 0,25/ 0,35 : 13 N/min. – 23 N/max.,  
maat 0,5 : 12 N/min. – 23 N/max.,  
maat 1,0 : 15 N/min. – 31 N/max.,  
maat 1,0 x 40 : 11 N/min. – 20 N/max.

**Max. spankoppel :** maat 0,25/ 0,35 : 20 Nm,  
maat 0,5 : 25 Nm,  
maat 1,0/1,0 x 40 : 30 Nm.

**Materiaal :** lichaam uit gebruid staal, zuigerstang  
uit geharde RVS, genitreerd,  
met een aluminium-titaanlaag.  
Met genitreerde geleidingsbus.  
*Op aanvraag in RVS.*

### Opties :

lichaam GW	aanslagkap Ref.	moer Ref.
M14 x 1	W.21011	W.21052
M14 x 1,5	W.21011.L	W.21052.L
M16 x 1	W.21011	W.22152
M16 x 1,5	W.21011.L	W.22152.L
M20 x 1	W.21111	W.21152
M20 x 1,5	W.21111.L	W.21152.L
M24 x 1,5	W.21211	W.21232
M25 x 1,5	W.21211.T	W.21232.T
M27 x 3	W.21211.R	W.21232.R

### Op aanvraag :

M15 x 1	M25 x 2
M20 x 1,25	M26 x 1,5
M22 x 1,5	M27 x 1,5
M24 x 1,25	M27 x 2

**SCHOKDEMPER "MEGA-LINE"  
0,25 - 0,35 - 0,5 - 1,0**

W.E / W.S / W.P

M14 x 1 / 1,5  
M16 x 1 / 1,5  
M20 x 1 / 1,5  
M24 x 1,5  
M25 x 1,5  
M27 x 3

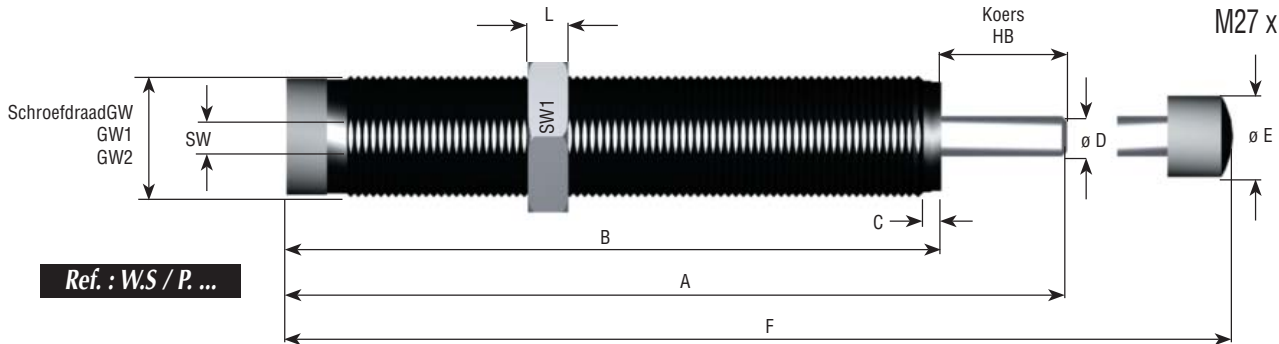

Ref. : W.S / P ...

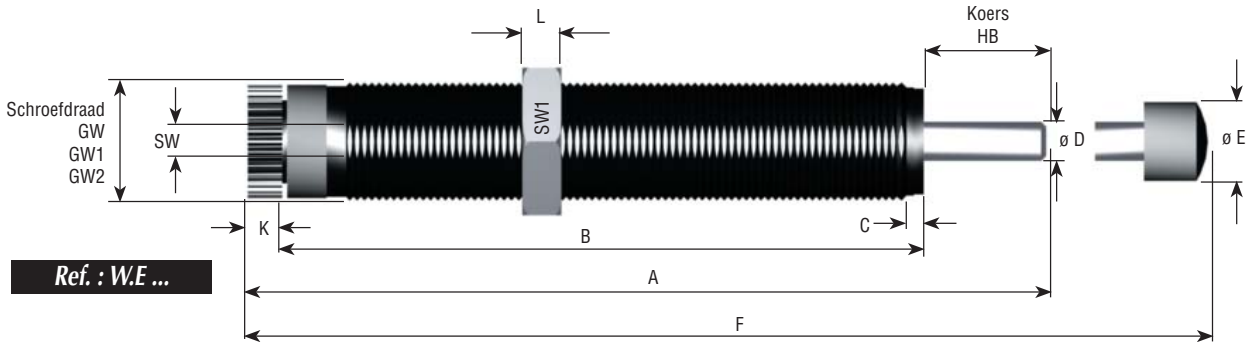

Ref. : W.E ...

**AFMETINGEN**

voor Ref.	Maat	GW	GW1	GW2 mm	A mm	B mm	C mm	ø D mm	ø E mm	F mm	K mm	L mm	SW mm	SW1
W.E	0,25	M14 x 1	M14 x 1,5	-	95	77	2,5	4	10	104	3,5	5	13	17
W.S	0,25	M14 x 1	M14 x 1,5	-	91	77	2,5	4	10	100	-	5	13	17
W.P	0,25	M14 x 1	M14 x 1,5	-	91	77	2,5	4	10	100	-	5	13	17
W.E	0,35	M16 x 1	M16 x 1,5	-	91	77	2,5	4	10	104	3,5	6	14	24
W.E	0,5 x 19	M20 x 1	M20 x 1,5	-	113	88	2,5	6	12	123	6	6	18	24
W.S	0,5 x 19	M20 x 1	M20 x 1,5	-	107	88	2,5	6	12	117	-	6	18	24
W.P	0,5 x 19	M20 x 1	M20 x 1,5	-	107	88	2,5	6	12	117	-	6	18	24
W.E	1,0	M24 x 1,5	M25 x 1,5	M27 x 3	141	108	3,5	8	16	154	8	8	23	30
W.S	1,0	M24 x 1,5	M25 x 1,5	M27 x 3	133	108	3,5	8	16	146	-	8	23	30
W.P	1,0	M24 x 1,5	M25 x 1,5	M27 x 3	133	108	3,5	8	16	146	-	8	23	30
W.E	1,0 x 40	M24 x 1,5	M25 x 1,5	M27 x 3	178	130	3,5	8	16	191	8	8	23	30
W.S	1,0 x 40	M24 x 1,5	M25 x 1,5	M27 x 3	170	130	3,5	8	16	183	-	8	23	30
W.P	1,0 x 40	M24 x 1,5	M25 x 1,5	M27 x 3	170	130	3,5	8	16	183	-	8	23	30

**SCHOKDEMPER "MEGA-LINE"  
0,25 - 0,35 - 0,5 - 1,0**

W.E / W.S / W.P

M14 x 1 / 1,5  
M16 x 1 / 1,5  
M20 x 1 / 1,5  
M24 x 1,5  
M25 x 1,5  
M27 x 3

**VERMOGEN**

Voor Ref.	Maat	HB mm	Energie opname			Effectieve massa (kg)				
			Constant load* Nm/HB (max.)	Emergency** Nm/HB (max.)	Nm/h (max.)	00 (very soft) min.- max.	10 (soft) min.- max.	20 (medium) min.- max.	30 (hard) min.- max.	40 (very hard) min.- max.
W.E	0,25	14	30	48	50.000	-	1,6 - 1.500	-	-	-
W.S	0,25	14	30	48	50.000	0,9 - 8	3,5 - 17	9,9 - 76	62 - 252	250 - 950
W.P	0,25	14	30	48	50.000	-	0,8 - 3,7	3 - 26	21 - 165	-
W.E	0,35	14	35	50	52.500	-	6,5 - 1750	-	-	-
W.E	0,5 x 19	19	100	160	76.500	-	9 - 4.500	-	-	-
W.S	0,5 x 19	19	100	160	76.500	2,6 - 10,6	10 - 86	40 - 209	170 - 800	680 - 4.050
W.P	0,5 x 19	19	100	160	76.500	-	2,6 - 12,5	10 - 89	69 - 555	-
W.E	1,0	25	220	352	105.600	-	22 - 11.000	-	-	-
W.S	1,0	25	220	352	105.600	6 - 29	24 - 120	70 - 460	440 - 2.050	1760 - 10.800
W.P	1,0	25	220	352	105.600	-	6 - 27,5	21 - 195	150 - 1200	-
W.E	1,0 x 40	40	390	624	175.500	-	38 - 18.000	-	-	-
W.S	1,0 x 40	40	390	624	175.500	15 - 103	44 - 216	135 - 962	780 - 3.600	3100 - 19.500
W.P	1,0 x 40	40	390	624	175.500	-	10 - 48	39 - 340	270 - 2150	-

\*Constate belasting/\*\*Belasting bij noodgeval

Maat	Standaard schroefdraad		S Schroefdraad optie		S Schroefdraad optie	
	GW	Ref.	GW1	Art.	GW2	Ref.
0,25	M 14 x 1	W.E.310.xx	M 14 x 1,5	W.E.310.xx.L	-	-
0,25	M 14 x 1	W.S.210.xx	M 14 x 1,5	W.S.210.xx.L	-	-
0,25	M 14 x 1	W.P.410.xx	M 14 x 1,5	W.P.410.xx.L	-	-
0,35	M 16 x 1	W.E.315.xx	M 16 x 1,5	W.E.315.xx.L	-	-
0,5 x 19	M 20 x 1	W.E.321.xx	M 20 x 1,5	W.E.321.xx.L	-	-
0,5 x 19	M 20 x 1	W.S.211.xx	M 20 x 1,5	W.S.211.xx.L	-	-
0,5 x 19	M 20 x 1	W.P.411.xx	M 20 x 1,5	W.P.411.xx.L	-	-
1,0	M 24 x 1,5	W.E.330.xx	M 25 x 1,5	W.E.330.xx.T	M 27 x 3	W.E.330.xx.R
1,0	M 24 x 1,5	W.S.212.xx	M 25 x 1,5	W.S.212.xx.T	M 27 x 3	W.S.212.xx.R
1,0	M 24 x 1,5	W.P.412.xx	M 25 x 1,5	W.P.412.xx.T	M 27 x 3	W.P.412.xx.R
1,0 x 40	M 24 x 1,5	W.E.331.xx	M 25 x 1,5	W.E.331.xx.T	M 27 x 3	W.E.331.xx.R
1,0 x 40	M 24 x 1,5	W.S.214.xx	M 25 x 1,5	W.S.214.xx.T	M 27 x 3	W.S.214.xx.R
1,0 x 40	M 24 x 1,5	W.P.414.xx	M 25 x 1,5	W.P.414.xx.T	M 27 x 3	W.P.414.xx.R

**BESTELVOORBEELD**

Ref. : W.S.214 - effectieve massa : 44 - 216 kg - M25 x 1,5 : Ref. : W.S.214.10.T

**SCHOKDEMPER "MEGA-LINE"  
0,25 - 0,35 - 0,5 - 1,0**

W.E / W.S / W.P

M14 x 1 / 1,5 – M16 x 1 / 1,5 – M20 x 1 / 1,5  
M24 x 1,5 – M25 x 1,5 – M27 x 3

**RECHTHOEKIGE FLENS**

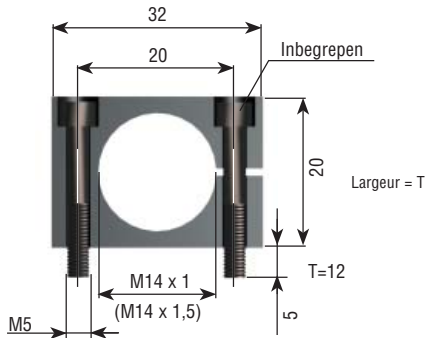

Ref. : W.S.21053  
(Ref. : W.S.21053.L)

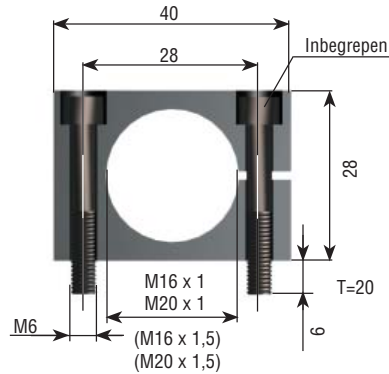

Ref. : W.S.22153  
Ref. : W.S.21153  
(Ref. : W.S.22153.L)  
(Ref. : W.S.21153.L)

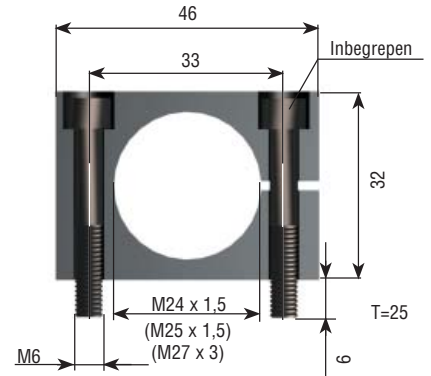

Ref. : W.S.21233  
(Ref. : W.S.21233.T)  
(Ref. : W.S.21233.R)

**AANSLAGBUS**

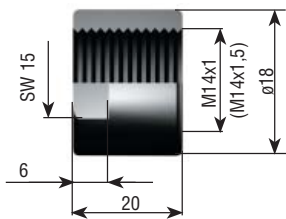

Ref. : W.21058  
(Ref. : W.21058.L)

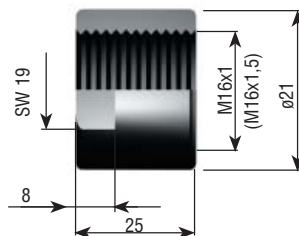

Ref. : W.22158  
(Ref. : W.22158.L)

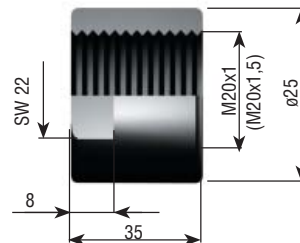

Ref. : W.21158  
(Ref. : W.21158.L)

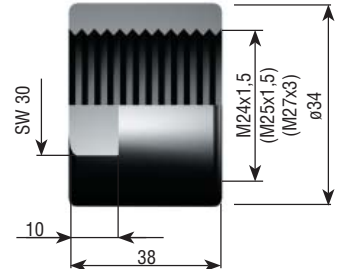

Ref. : W.21238  
(Ref. : W.21238.T)  
(Ref. : W.21238.R)

**AK 1 VOOR RADIALE BELASTINGEN (3 TOT 20°)**

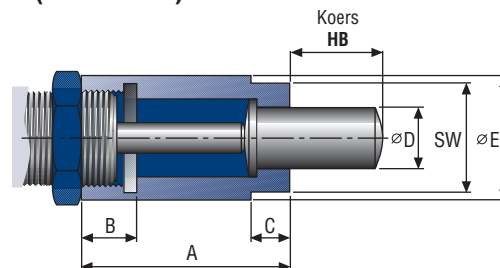

Art.	GW	GW1	A	B	C	ø D	ø E	SW
W.S.21019	M14 x 1	M14 x 1,5	32,0	10,0	6	9	18	15
W.S.22119	M16 x 1	M16 x 1,5	33,0	10,0	5	12	20	17
W.S.21119	M20 x 1	M20 x 1,5	42,0	16,0	8	12	24	22
W.S.21219	M24 x 1,5	M25 x 1,5 / M27 x 3	53,5	14,5	10	16	29	27

## SCHOKDEMPER "MEGA-LINE" 1,25

W.E / W.S / W.P

M32 x 1,5

M33 x 1,5



### Technische kenmerken :

Ref. : **W.E** : regelbaar, lineair type.

Ref. : **W.S** : zelf instelbaar, lineair type.

Ref. : **W.P** : zelf instelbaar, progressief type.

**Gebruikstemperatuur** : -20° tot +80°C

**Uitvoering** : Robuust lichaam zonder circlips.  
De helicoïdale vorm van het binnenlichaam laat een betere oliecirculatie toe zodat de energie dus ook op een efficiëntere manier zal oplossen :

- max. + 300% van de energie,
- max. 50% kostenbesparing per Nm.

Instelling aan de achterkant (binnenzeskant) met regelmogelijkheden zonder werktuigen d.m.v. een regelschroef vooraan.

Met afgeplatte vlakken voor een gemakkelijke montage. Met ingebouwde eindaanslag – maximale veiligheid.

**Eigen gewicht** : koers HB = 25 mm : 0,45 kg

koers HB = 50 mm : 0,55 kg

**Impactsnelheid** : Ref. : **W.E** : 0,02 tot 6,0 m/s.

Ref. : **W.S** : 0,10 tot 6,0 m/s.

Ref. : **W.P** : 0,40 tot 8,0 m/s.

**Veersterkte** : koers HB = 25 mm : 30 N/min. – 50 N/max.

koers HB = 50 mm : 23 N/min. – 50 N/max.

**Spankoppel** : max. leverbaar : 40 Nm

**Materiaal** : lichaam uit gebruid staal, zuigerstang uit geharde RVS, genitreerd met een aluminium-titaanlaag.

Met genitreerde geleidingsbus.

### Opties :

lichaam	aanslagkap	moer
GW	Ref.	Ref.
M32 x 1,5	<b>W.S.23011</b>	<b>W.S.23012</b>
M33 x 1,5	<b>W.S.23011.H</b>	<b>W.S.23012.H</b>

### Op aanvraag :

M30 x 1,5	M36 x 1,5
M30 x 2	M37 x 1,5



**SCHOKDEMPER "MEGA-LINE"  
1,25**

W.E / W.S / W.P

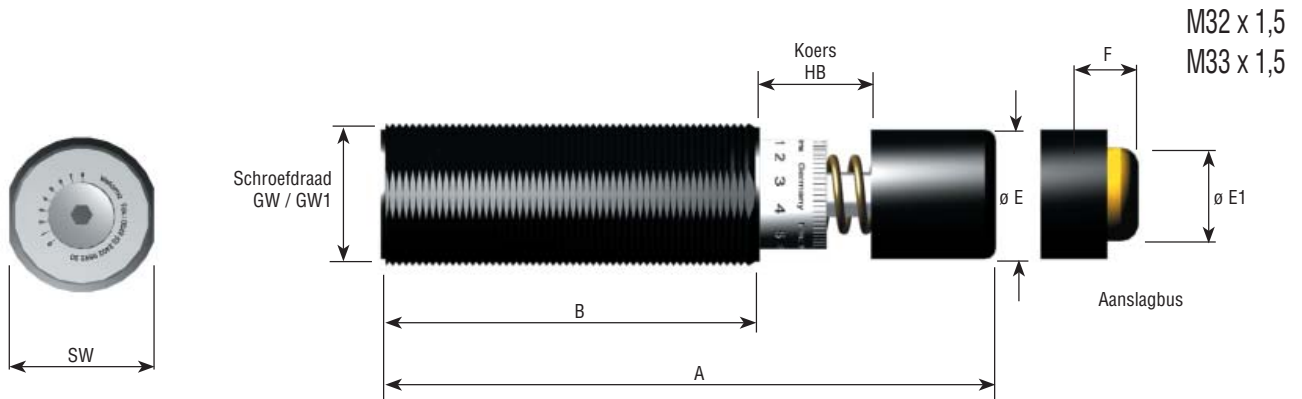

**AFMETINGEN**

F (\*) om de totale lengte van de schokdemper met aanslagkap te bekomen maakt men de som van de maten A + F.

Voor Ref.	Maat	GW	GW1	A mm	B mm	Ø E mm	Ø E1 mm	F(*) mm	SW mm
W.E	1,25 x 1	M32 x 1,5	M33 x 1,5	138	85	29	21	16	30
W.S	1,25 x 1	M32 x 1,5	M33 x 1,5	138	85	29	21	16	30
W.P	1,25 x 1	M32 x 1,5	M33 x 1,5	138	85	29	21	16	30
W.E	1,25 x 2	M32 x 1,5	M33 x 1,5	188	110	29	21	16	30
W.S	1,25 x 2	M32 x 1,5	M33 x 1,5	188	110	29	21	16	30
W.P	1,25 x 2	M32 x 1,5	M33 x 1,5	188	110	29	21	16	30

**VERMOGEN**

Voor Ref.	Maat	HB	Energie opname				Effectieve massa (kg)					
			Constant load* Nm/HB (max.)	Emergency** Nm/HB (max.)	Nm/h (max.)	External tank*** Nm/h	00 (very soft)		20 (medium)		30 (hard)	40 (very hard)
							min.- max.	min.- max.	min.- max.	min.- max.	min.- max.	
W.E	1,25 x 1	25	300	480	120.000	240.000	10 - 100	60 - 2.950	600 - 89.000	-	-	
W.S	1,25 x 1	25	300	480	120.000	240.000	7 - 32	28 - 130	80 - 590	440 - 2.050	2.000 - 12.500	
W.P	1,25 x 1	25	300	480	120.000	240.000	-	7 - 35	30 - 260	207 - 1.650	-	
W.E	1,25 x 2	50	500	800	150.000	300.000	15 - 160	100 - 4.000	800 - 120.000	-	-	
W.S	1,25 x 2	50	500	800	150.000	300.000	13 - 60	56 - 240	160 - 1.200	1.000 - 4.200	4.000 - 25.000	
W.P	1,25 x 2	50	500	800	150.000	300.000	-	7 - 35	30 - 260	207 - 1.650	-	

\*Constante belasting/\*\*Belasting bij noodgeval/\*\*uitwendig reservoir

Maat	Standaard schroefdraad GW		S Schroefdraad optie GW1	
	GW	Ref.	GW1	Ref.
1,25 x 1	M32 x 1,5	W.E.340.xx	M33 x 1,5	W.E.340.xx.H
1,25 x 1	M32 x 1,5	W.S.230.xx	M33 x 1,5	W.S.230.xx.H
1,25 x 1	M32 x 1,5	W.P.430.xx	M33 x 1,5	W.P.430.xx.H
1,25 x 2	M32 x 1,5	W.E.341.xx	M33 x 1,5	W.E.341.xx.H
1,25 x 2	M32 x 1,5	W.S.231.xx	M33 x 1,5	W.S.231.xx.H
1,25 x 2	M32 x 1,5	W.P.431.xx	M33 x 1,5	W.P.431.xx.H

**BESTELVOORBEELD**

Ref. : W.P.430 - effectieve massa : 30 - 260 kg - M32 x 1,5 : Ref. : W.P.430.20

**SCHOKDEMPER "MEGA-LINE"  
1,25**

W.E / W.S / W.P

M32 x 1,5

M33 x 1,5

**MOER**

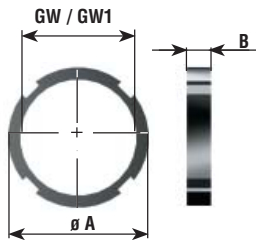

**VIERKANTE FLENS**

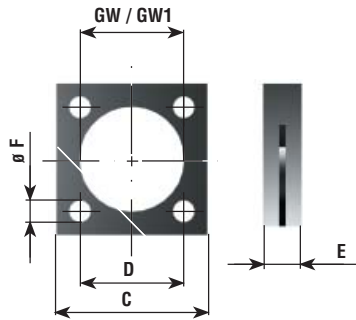

**AANSLAGBUS**

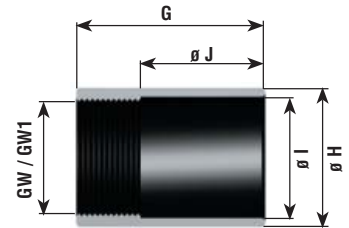

GW	GW1	ø A mm	B mm	C mm	D mm	E mm	ø F mm	G mm	ø H mm	ø I mm	ø J mm
M32 x 1,5	M33 x 1,5	38	6,5	44	32	12	6,6	60	38	33	35

**BESCHERMINGSBALG "MEGA-LINE"**



**Opties**

Schroefdraad	Moer	Vierkante flens	Aanslagbus	Beschermingsbalg
M32 x 1,5	W.S.23012	W.S.23014	W.S.23018	W.S.23117
M33 x 1,5	W.S.23012.H	W.S.23014.H	W.S.23018.H	W.S.23117

**SCHOKDEMPER "MEGA-LINE"  
1,25**

W.E / W.S / W.P

**BEVESTIGINGSVOET**

M32 x 1,5  
M33 x 1,5

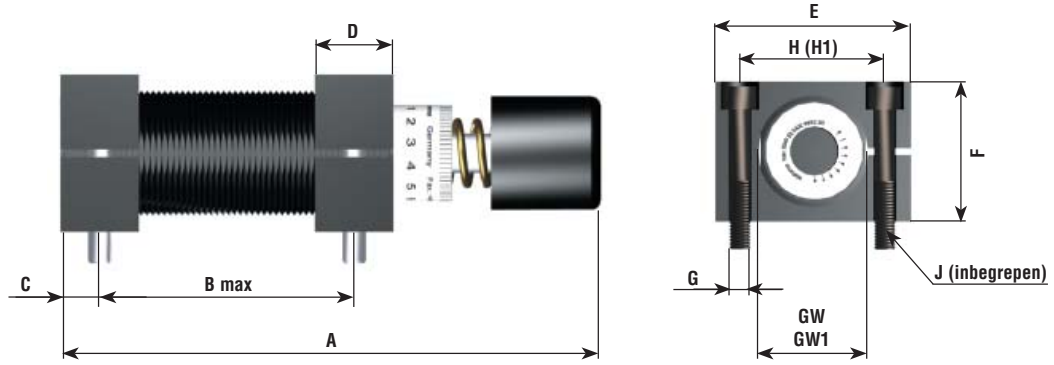

GW	Ref.
M32 x 1,5	W.S.23015
M33 x 1,5	W.S.23015.H

**AFMETINGEN**

	GW	GW1 (*)	A	B max	C	D	E	F	ø G	H	H1(*)	I	J
			mm	mm	mm	mm	mm	mm	mm	mm	mm	mm	mm
1,25 x 1	M32 x 1,5	M33 x 1,5	138	65	10	20	56	40	6,6	41	42	8	M6x40
1,25 x 2	M32 x 1,5	M33 x 1,5	188	90	10	20	56	40	6,6	41	42	8	M6x40

(\*) : GW1 - H1

**GELEDE BEVESTIGING (zonder veer)**

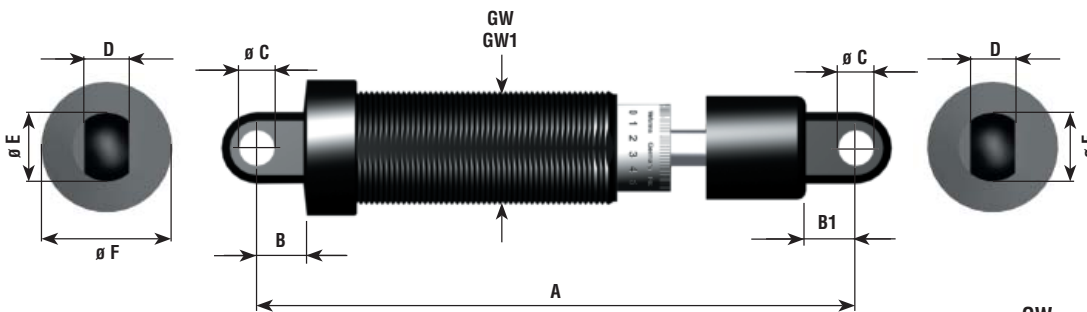

GW	Ref.
M32 x 1,5	W.S.23016
M33 x 1,5	W.S.23016.H

**AFMETINGEN**

	GW	GW1	A max	B	B1	ø C	D	ø E	ø F	G	H	I	J	ø K	L	M	N	ø O	P
			mm	mm	mm	mm	mm	mm	mm	mm	mm	mm	mm	mm	mm	mm	mm	mm	mm
1,25 x 1	M32 x 1,5	M33 x 1,5	170	14	14	10	13	20	38	45	32	14	34	6,5	22	13	5	10	20
1,25 x 2	M32 x 1,5	M33 x 1,5	220	14	14	10	13	20	38	45	32	14	34	6,5	22	13	5	10	20



Ref. : W.S.23016.1

Zwenkflenzen N

**SCHOKDEMPER "MEGA-LINE"  
1,50**

W.E / W.S / W.P

M45 x 2  
M45 x 1,5  
M42 x 1,5



**Technische kenmerken :**

Ref. : **W.E** : regelbaar, lineair type.  
Ref. : **W.S** : zelf instelbaar, lineair type.  
Ref. : **W.P** : zelf instelbaar, progressief type.

**Gebruikstemperatuur :** -20° tot +80°C

**Uitvoering :** Robuust lichaam zonder circlips.  
De helicoïdale vorm van het binnenlichaam laat een betere oliecirculatie toe zodat de energie dus ook op een efficiëntere manier zal oplossen :

- max. + 300% van de energie,
  - max. 50% kostenbesparing per Nm.
- Instelling aan de achterkant (binnenzeskant) met regelmogelijkheden zonder werktuigen d.m.v. een regelschroef vooraan.

Met afgeplatte vlakken voor een gemakkelijkere montage. Met ingebouwde eindaanslag – maximale veiligheid.

**Eigen gewicht :** koers HB = 25 mm : 0,95 kg  
koers HB = 50 mm : 1,10 kg  
koers HB = 75 mm : 1,20 kg

**Impactsnelheid :** Ref. : **W.E** : 0,02 tot 6,0 m/s.  
Ref. : **W.S** : 0,10 tot 6,0 m/s.  
Ref. : **W.P** : 0,40 tot 8,0 m/s.

**Veersterkte :** koers HB = 25 mm : 50 N/min. – 70 N/max.  
koers HB = 50 mm : 35 N/min. – 70 N/max.  
koers HB = 75 mm : 35 N/min. – 80 N/max.

**Spankoppel :** max. leverbaar : 40 Nm  
**Materiaal :** lichaam uit gebruid staal, zuigerstang uit geharde RVS, genitreerd met een aluminium-titaanlaag.

Met genitreerde geleidingsbus.  
*Op aanvraag in RVS.*

**Opties :**

lichaam GW	aanslagkap Ref.	moer Ref.
M45 x 2	<b>W.S.24011</b>	<b>W.S.24012</b>
M45 x 1,5	<b>W.S.24011.L</b>	<b>W.S.24012.L</b>
M42 x 1,5	<b>W.S.24011.K</b>	<b>W.S.24012.K</b>

**Op aanvraag :**

M42 x 1,5	1 3/4" - 12 UNF
M42 x 2	1 1/4" - 12 UNF
M42 x 3	

**SCHOKDEMPER "MEGA-LINE"  
1,50**

W.E / W.S / W.P

M45 x 2  
M45 x 1,5  
M42 x 1,5

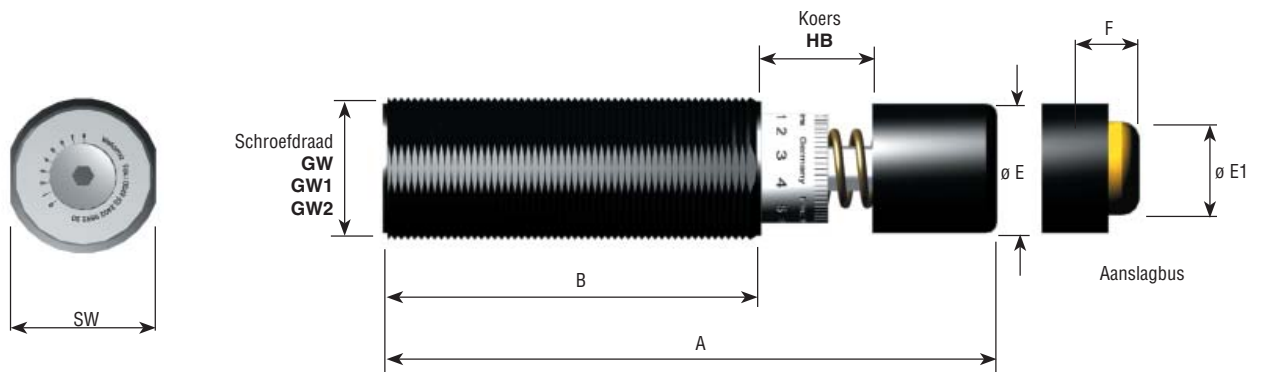

**AFMETINGEN**

Voor Ref.	Maat	GW	GW1	GW2	A mm	B mm	ø E mm	ø E1 mm	F(*) mm	SW mm
W.E	1,5 x 1	M45 x 2	M45 x 1,5	M42 x 1,5	146	89	39,6	31	25	41
W.S	1,5 x 1	M45 x 2	M45 x 1,5	M42 x 1,5	146	89	39,6	31	25	41
W.P	1,5 x 1	M45 x 2	M45 x 1,5	M42 x 1,5	146	89	39,6	31	25	41
W.E	1,5 x 2	M45 x 2	M45 x 1,5	M42 x 1,5	196	114	39,6	31	25	41
W.S	1,5 x 2	M45 x 2	M45 x 1,5	M42 x 1,5	196	114	39,6	31	25	41
W.P	1,5 x 2	M45 x 2	M45 x 1,5	M42 x 1,5	196	114	39,6	31	25	41
W.E	1,5 x 3	M45 x 2	M45 x 1,5	M42 x 1,5	246	139	39,6	31	25	41
W.S	1,5 x 3	M45 x 2	M45 x 1,5	M42 x 1,5	246	139	39,6	31	25	41
W.P	1,5 x 3	M45 x 2	M45 x 1,5	M42 x 1,5	246	139	39,6	31	25	41

F(\*) : om de totale lengte van de schokdemper met aanslagkap te bekomen maakt men de som van de maten A + F.

**SCHOKDEMPER "MEGA-LINE"  
1,50**

W.E / W.S / W.P

M45 x 2  
M45 x 1,5  
M42 x 1,5

**VERMOGEN**

Voor Ref.	HB		Energie opname				Effectieve massa (kg)				
			Constant load* Nm/HB (max.)	Emergency** Nm/HB (max.)	External tank*** Nm/h (max.)		00 (very soft) min.- max.	10 (soft) min.- max.	20 (medium) min.- max.	30 (hard) min.- max.	40 (very hard) min.- max.
W.E	1,5 x 1	25	870	1.400	261.000	450.000	30 - 250	150 - 21.000	6.200 - 240.000	-	-
W.S	1,5 x 1	25	870	1.400	261.000	450.000	24 - 114	98 - 480	280 - 2.100	1.740 - 8.200	6.960 - 43.500
W.P	1,5 x 1	25	870	1.400	261.000	450.000	-	24 - 108	85 - 770	600 - 4.800	-
W.E	1,5 x 2	50	1350	2.160	340.000	544.000	45 - 430	300 - 26.000	10.800 - 330.000	-	-
W.S	1,5 x 2	50	1350	2.160	340.000	544.000	35 - 170	160 - 680	440 - 2900	2.700 - 12.700	10.800 - 67.500
W.P	1,5 x 2	50	1350	2.160	340.000	544.000	-	37 - 160	130 - 1200	940 - 7500	-
W.E	1,5 x 3	75	2100	3.360	420.000	670.000	70 - 670	450 - 27.600	16.800 - 500.000	-	-
W.S	1,5 x 3	75	2100	3.360	420.000	670.000	40 - 270	240 - 1.100	670 - 5.000	4.200 - 19.500	16.800 - 105.000
W.P	1,5 x 3	75	2100	3.360	420.000	670.000	-	58 - 260	200 - 1.850	1.450 - 11.600	-

\*Constate belasting/\*\*Belasting bij noodgeval/\*\*\*uitwendig reservoir

Maat	Standaard schroefdraad		S Schroefdraad optie		S Schroefdraad optie	
	GW	Art.	GW1	Ref.	GW2	Ref.
1,5 x 1	M45 x 2	W.E.350.xx	M45 x 1,5	W.E.350.xx.L	M42 x 1,5	W.E.350.xx.K
1,5 x 1	M45 x 2	W.S.240.xx	M45 x 1,5	W.S.240.xx.L	M42 x 1,5	W.S.240.xx.K
1,5 x 1	M45 x 2	W.P.440.xx	M45 x 1,5	W.P.440.xx.L	M42 x 1,5	W.P.440.xx.K
1,5 x 2	M45 x 2	W.E.351.xx	M45 x 1,5	W.E.351.xx.L	M42 x 1,5	W.E.351.xx.K
1,5 x 2	M45 x 2	W.S.241.xx	M45 x 1,5	W.S.241.xx.L	M42 x 1,5	W.S.241.xx.K
1,5 x 2	M45 x 2	W.P.441.xx	M45 x 1,5	W.P.441.xx.L	M42 x 1,5	W.P.441.xx.K
1,5 x 3	M45 x 2	W.E.352.xx	M45 x 1,5	W.E.352.xx.L	M42 x 1,5	W.E.352.xx.K
1,5 x 3	M45 x 2	W.S.242.xx	M45 x 1,5	W.S.242.xx.L	M42 x 1,5	W.S.242.xx.K
1,5 x 3	M45 x 2	W.P.442.xx	M45 x 1,5	W.P.442.xx.L	M42 x 1,5	W.P.442.xx.K

**BESTELVOORBEELD**

Ref. : W.S.240 - effectieve massa : 1740 - 8200 kg - M42 x 1,5 : Ref. : W.S.240.30.K

**SCHOKDEMPER "MEGA-LINE"  
1,50**

W.E / W.S / W.P

M45 x 2  
M45 x 1,5  
M42 x 1,5

**MOER**

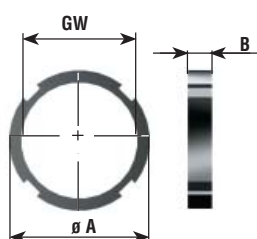

**VIERKANTE FLENS**

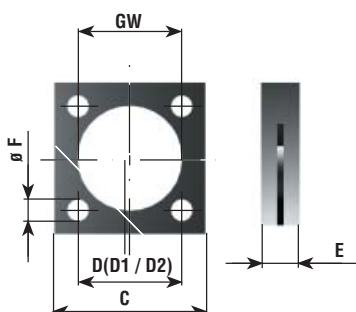

**AANSLAGBUS**

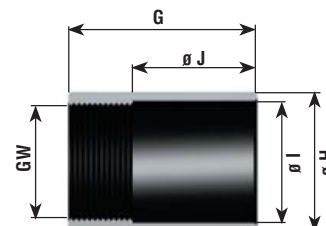

GW	ø A mm	B mm	C mm	D mm	D1 mm	D2 mm	E mm	ø F mm	G mm	ø H mm	ø I mm	ø J mm
M45 x 2	54	8	56	43	42	42	15	9	65	54	47	35

**BESCHERMINGSBALG "MEGA-LINE"**



**AFMETINGEN**

GW	ø E mm
1,5 x 1	60
1,5 x 2	80
1,5 x 3	80

**Opties**

Schroefdraad	Moer	Vierkante flens	Aanslagbus	Beschermingsbalg
M45 x 2	W.S.24012	W.S.24014	W.S.24018	W.S.24117
M45 x 1,5	W.S.24012.L	W.S.24014.L	W.S.24018.L	W.S.24117
M42 x 1,5	W.S.24012.K	W.S.24014.K	W.S.24018.K	W.S.24117

**SCHOKDEMPER "MEGA-LINE"  
1,50**

W.E / W.S / W.P

**BEVESTIGINGSVOET**

M45 x 2  
M45 x 1,5  
M42 x 1,5

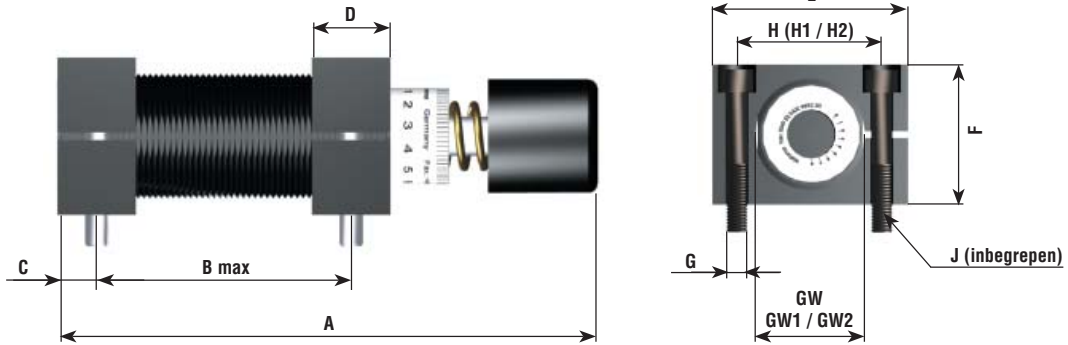

**AFMETINGEN**

GW	Ref.
M45 x 2	W.S.24015
M45 x 1,5	W.S.24015.L
M42 x 1,5	W.S.24015.K

Maat	GW	GW1	GW2	A	B max	C	D	E	F	ø G	H(*)	H1(*)	H2(*)	I	J
				mm	mm	mm	mm	mm	mm	mm	mm	mm	mm	mm	mm
1,5 x 1	M45 x 2	M45 x 1,5	M42 x 1,5	146	64	12,5	25	80	56	9	58	60	60	16	M8 x 50
1,5 x 2	M45 x 2	M45 x 1,5	M42 x 1,5	196	89	12,5	25	80	56	9	58	60	60	16	M8 x 50
1,5 x 3	M45 x 2	M45 x 1,5	M42 x 1,5	246	114	12,5	25	80	56	9	58	60	06	16	M8 x 50

(\*) : GW - H / GW1 - H1 / GW2 - H2

**GELEDE BEVESTIGING (zonder veer)**

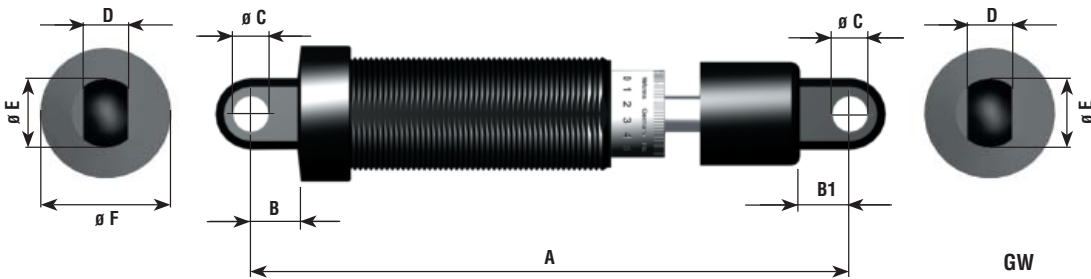

**AFMETINGEN**

GW	Ref.
M45 x 2	W.S.24016
M45 x 1,5	W.S.24016.L
M42 x 1,5	W.S.24016.K

Maat	GW	A max	B	B1	ø C	D	ø E	ø F	G	H	I	J	ø K	L	M	N	ø O	P
		mm	mm	mm	mm	mm	mm	mm	mm	mm	mm	mm	mm	mm	mm	mm	mm	mm
1,5 x 1	au choix	200	28	18	16	20	28	53	65	46	21	45	9	27	15	6	16	29
1,5 x 2	au choix	250	28	18	16	20	28	53	65	46	21	45	9	27	15	6	16	29
1,5 x 3	au choix	300	28	18	16	20	28	53	65	46	21	45	9	27	15	6	16	29



Ref. : W.S.24016.1

Zwenkflenzen



**SCHOKDEMPER "MEGA-LINE"  
2,0**

W.E / W.S / W.P

M62 x 2  
M64 x 2



**Technische kenmerken :**

Ref. : **W.E** : regelbaar, lineair type.  
Ref. : **W.S** : zelf instelbaar, lineair type.  
Ref. : **W.P** : zelf instelbaar, progressief type.

**Gebruikstemperatuur :** -20° tot +80°C

**Uitvoering :** Robuust lichaam zonder circlips.  
De helicoidale vorm van het binnenlichaam laat een betere oliecirculatie toe zodat de energie dus ook op een efficiëntere manier zal oplossen :

- max. + 300% van de energie,
- max. 50% kostenbesparing per Nm.

Instelling aan de achterkant (binnenzeskant) met regelmogelijkheden zonder werktuigen d.m.v. een regelschroef vooraan. Met afge-

montage. Met platte vlakken voor een gemakkelijkere ingebouwde eindaanslag – maximale veiligheid.

**Opties :**

lichaam	aanslagkap	moer
GW	Ref.	Ref.
M62 x 2	<b>W.S.25011</b>	<b>W.S.25012</b>
M64 x 2	<b>W.S.25011.L</b>	<b>W.S.25012.L</b>

**Eigen gewicht :** koers HB = 25 mm : 2,0 kg,

koers HB = 50 mm : 3,0 kg,  
koers HB = 100 mm : 3,9 kg,  
koers HB = 150 mm : 4,8 kg,

**Impactsnelheid :** Ref. : **W.E** : 0,02 tot 6,0 m/s.  
Ref. : **W.S** : 0,10 tot 6,0 m/s.  
Ref. : **W.P** : 0,40 tot 8,0 m/s.

**Veersterkte :** koers HB = 25 mm : 50 N/min. – 130 N/max.  
koers HB = 50 mm : 40 N/min. – 130 N/max.  
koers HB = 100 mm : 45 N/min. – 130 N/max.  
koers HB = 150 mm : 35 N/min. – 100 N/max.

**Spankoppel :** max. leverbaar : 40 Nm

**Materiaal :** lichaam uit gebruid staal, zuigerstang uit geharde RVS, genitreed met een aluminium-titaanlaag. Met genitreeerde geleidingsbus.

**Op aanvraag :**

2 1/2" - 12 UNF

**SCHOKDEMPER "MEGA-LINE"  
2,0**

W.E / W.S / W.P

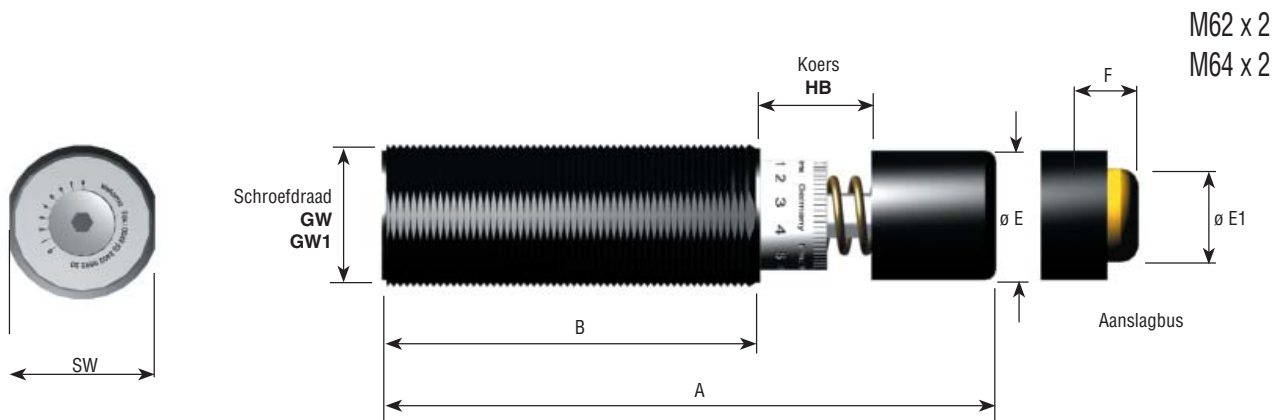

**AFMETINGEN**

Voor Ref.	Maat	GW	GW1	A mm	B mm	ø E mm	ø E1 mm	F(*) mm	SW mm
W.E	2,0 x 1	M62 x 2	M64 x 2	186	104	59,6	45	25	60
W.S	2,0 x 1	M62 x 2	M64 x 2	186	104	59,6	45	25	60
W.P	2,0 x 1	M62 x 2	M64 x 2	186	104	59,6	45	25	60
W.E	2,0 x 2	M62 x 2	M64 x 2	236	129	59,6	45	25	60
W.S	2,0 x 2	M62 x 2	M64 x 2	236	129	59,6	45	25	60
W.P	2,0 x 2	M62 x 2	M64 x 2	236	129	59,6	45	25	60
W.E	2,0 x 4	M62 x 2	M64 x 2	336	179	59,6	45	25	60
W.S	2,0 x 4	M62 x 2	M64 x 2	336	179	59,6	45	25	60
W.P	2,0 x 4	M62 x 2	M64 x 2	336	179	59,6	45	25	60
W.E	2,0 x 6	M62 x 2	M64 x 2	453	246	59,6	45	25	60
W.S	2,0 x 6	M62 x 2	M64 x 2	453	246	59,6	45	25	60
W.P	2,0 x 6	M62 x 2	M64 x 2	453	246	59,6	45	25	60

F(\*) : om de totale lengte van de schokdemper met aanslagkap te bekomen maakt men de som van de maten A + F.

**SCHOKDEMPER "MEGA-LINE"  
2,0**

W.E / W.S / W.P

M62 x 2

M64 x 2

**VERMOGEN**

Voor Ref.	Maat	HB	Energie opname				Effectieve massa (kg)				
			Constant load*	Emergency**	External tank***		00 (very soft)	10 (soft)	20 (medium)	30 (hard)	40 (very hard)
			Nm/HB (max.)	Nm/HB (max.)	Nm/h (max.)	Nm/h	min.- max.	min.- max.	min.- max.	min.- max.	min.- max.
W.E	2,0 x 1	25	1.500	2.400	150.000	240.000	60 - 480	300 - 41.150	12.000 - 470.000	-	-
W.S	2,0 x 1	25	1.500	2.400	150.000	240.000	31 - 197	170 - 830	480 - 3.700	3.000 - 14.100	12.000 - 75.000
W.P	2,0 x 1	25	1.500	2.400	150.000	240.000	-	31 - 187	150 - 1.330	1.030 - 8.300	-
W.E	2,0 x 2	50	2.500	4.000	250.000	400.000	80 - 800	500 - 63.700	14.000 - 600.000	-	-
W.S	2,0 x 2	50	2.500	4.000	250.000	400.000	52 - 330	280 - 1.385	800 - 6.150	5.000 - 23.500	20.000 - 125.000
W.P	2,0 x 2	50	2.500	4.000	250.000	400.000	-	52 - 310	250 - 2.200	1.730 - 13.800	-
W.E	2,0 x 4	100	5.000	8.000	350.000	525.000	160 - 1.600	1.000 - 62.500	40.000 - 1.000.000	-	-
W.S	2,0 x 4	100	5.000	8.000	350.000	525.000	104 - 650	565 - 2.770	1.600 - 12.350	10.000 - 47.200	40.000 - 250.000
W.P	2,0 x 4	100	5.000	8.000	350.000	525.000	-	100 - 625	490 - 4.400	3.460 - 27.700	-
W.E	2,0 x 6	150	8.000	12.800	400.000	650.000	250 - 2.400	1.250 - 105.000	64.000 - 1.000.000	-	-
W.S	2,0 x 6	150	8.000	12.800	400.000	650.000	160 - 1.050	905 - 4.430	2.560 - 1.9750	16.000 - 75.500	64.000 - 400.000
W.P	2,0 x 6	150	8.000	12.800	400.000	650.000	-	160 - 1.000	790 - 7.100	5.530 - 44.000	-

\*Constante belasting/\*\*Belasting bij noodgeval/\*\*uitwendig reservoir

Maat	Standaard schroefdraad		Schoefdraad optie	
	GW	Ref.	GW1	Ref.
2,0 x 1	M62 x 2	W.E.365.xx	M64 x 2	W.E.365.xx.L
2,0 x 1	M62 x 2	W.S.255.xx	M64 x 2	W.S.255.xx.L
2,0 x 1	M62 x 2	W.P.455.xx	M64 x 2	W.P.455.xx.L
2,0 x 2	M62 x 2	W.E.360.xx	M64 x 2	W.E.360.xx.L
2,0 x 2	M62 x 2	W.S.250.xx	M64 x 2	W.S.250.xx.L
2,0 x 2	M62 x 2	W.P.450.xx	M64 x 2	W.P.450.xx.L
2,0 x 4	M62 x 2	W.E.361.xx	M64 x 2	W.E.361.xx.L
2,0 x 4	M62 x 2	W.S.251.xx	M64 x 2	W.S.251.xx.L
2,0 x 4	M62 x 2	W.P.451.xx	M64 x 2	W.P.451.xx.L
2,0 x 6	M62 x 2	W.E.362.xx	M64 x 2	W.E.362.xx.L
2,0 x 6	M62 x 2	W.S.252.xx	M64 x 2	W.S.252.xx.L
2,0 x 6	M62 x 2	W.P.452.xx	M64 x 2	W.P.452.xx.L

**BESTELVOORBEELD**

Ref. : W.E.361 - effectieve massa : 1000 - 62.500 kg - M62 x 2 : Ref. : W.E.361.10

## SCHOKDEMPER "MEGA-LINE" 2,0

Ref. : W.E / W.S / W.P

M62 x 2

M64 x 2

### MOER

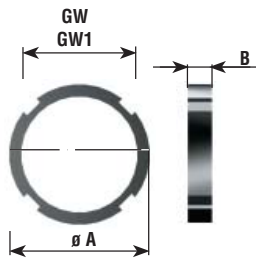

### VIERKANTE FLENS

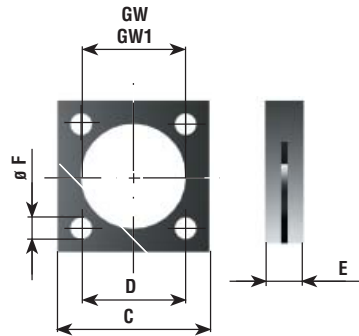

### AANSLAGBUS

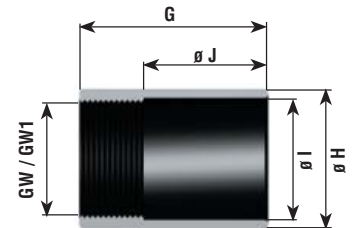

GW	GW1(*)	Ø A mm	B mm	C mm	D mm	D1(*) mm	E mm	Ø F mm	G mm	Ø H mm	Ø I mm	Ø J mm
M62 x 2	M64 x 2	74	10	80	60	58	20	11	100	74	65	60

(\*) : GW1 - D1

### BESCHERMINGSBALG "MEGA-LINE"



### Opties

Schroefdraad	Moer	Vierkante flens	Aanslagbus	Beschermingsbalg
M62 x 2	W.S.25012	W.S.25014	W.S.25018	W.S.25117
M64 x 2	W.S.25012.L	W.S.25014.L	W.S.25018.L	W.S.25117

**SCHOKDEMPER "MEGA-LINE"  
2,0**

Ref. : W.E / W.S / W.P

**BEVESTIGINGSVOET**

M62 x 2  
M64 x 2

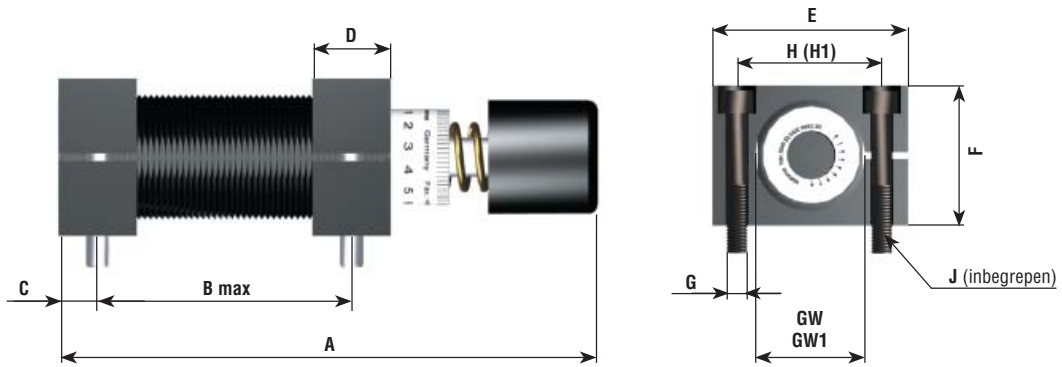

**AFMETINGEN**

Maat	GW	GW1(*)	A	B max	C	D	E	F	ø G	H	H1(*)	I	J	mm
2,0 x 1	M62 x 2	M64 x 2	186	79	12,5	25	100	80	11	76	78	12		M10 x 80
2,0 x 2	M62 x 2	M64 x 2	236	104	12,5	25	100	80	11	76	78	12		M10 x 80
2,0 x 4	M62 x 2	M64 x 2	336	154	12,5	25	100	80	11	76	78	12		M10 x 80
2,0 x 6	M62 x 2	M64 x 2	453	221	12,5	25	100	80	11	76	78	12		M10 x 80

GW	Art.
M62 x 2	W.S.25015
M64 x 2	W.S.25015.L

(\*) : GW1 - H1

**GELEDE BEVESTIGING (zonder veer)**

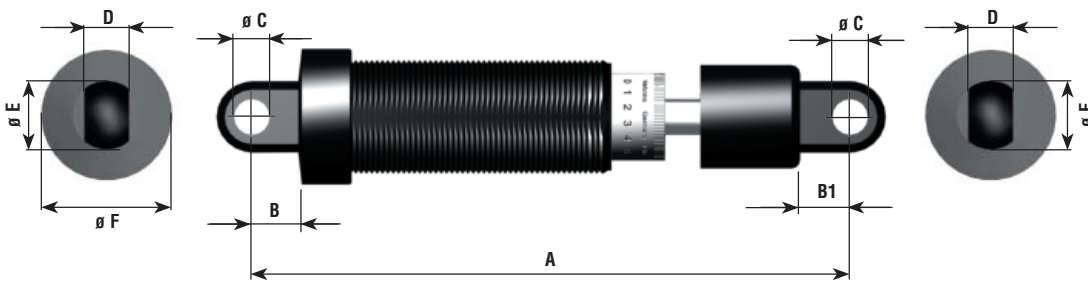

**AFMETINGEN**

GW	GW1	A max	B	B1	ø C	D	ø E	ø F	G	H	I	J	ø K	L	M	N	ø O	P	
2,0 x 1	M62 x 2	M64 x 2	272	35	35	20	24	40	74	95	72	25	65	11	36	22	10	20	42
2,0 x 2	M62 x 2	M64 x 2	322	35	35	20	24	40	74	95	72	25	65	11	36	22	10	20	42
2,0 x 4	M62 x 2	M64 x 2	422	35	35	20	24	40	74	95	72	25	65	11	36	22	10	20	42
2,0 x 6	M62 x 2	M64 x 2	539	35	35	20	24	40	74	95	72	25	65	11	36	22	10	20	42

GW	Ref.
M62 x 2	W.S.25016
M64 x 2	W.S.25016.L

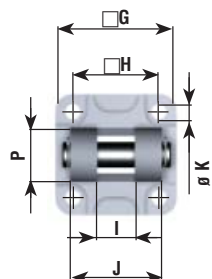

Ref. : W.S.25016.1

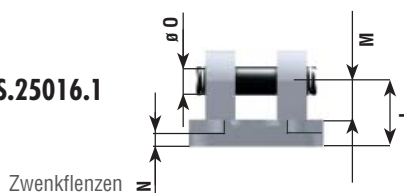

Zwenkflenzen