

SPANHENDEL UIT STAAL OF RVS

H.24430.0 / GWN.212



MATERIAAL EN UITVOERING :

Ref. H.2443 : decolleteerstaal, fijn gedraaid en gepolijst

Ref. GWN.212 : uit RVS 1.4305, mat gezandstraald, bol DIN 319 uit zwarte duroplast.

- vorm E : met binnenschroefdraad - Ø d2,
- vorm F : met gladde boring - Ø d3.

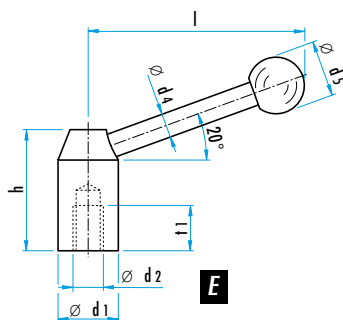

VORM E

Ø d1	Ø d2	Ø d4	Ø d5	h	l	t1	Ref.	
							staal	RVS
20	M 8	8	20	33	67	15	H.24430.0022	-
22	M 8	8	20	37	70	15	-	H.24430.0230
22	M10	8	20	37	82	15	H.24430.0032	-
25	M10	10	25	42	96	15	-	H.24430.0236
25	M12	10	25	42	96	18	H.24430.0038	-
28	M12	12	30	47	110	18	H.24430.0042	H.24430.0242
32	M16	12	32	52	124	23	H.24430.0048	H.24430.0248
36	M16	14	35	58	138	24	H.24430.0052	-
40	M20	16	40	64	152	27	H.24430.0058	-
45	M20	16	40	71	170	30	H.24430.0062	-

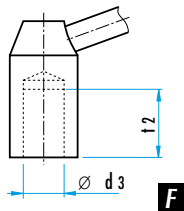

VORM F

Ø d1	Ø d3	Ø d4	Ø d5	h	l	t2	Ref. staal
20	10	8	20	33	67	16	H.24430.0020
22	10	8	20	37	82	18	H.24430.0030
25	12	10	25	42	96	21	H.24430.0035
28	12	12	30	47	110	22	H.24430.0040
32	16	12	32	52	124	25	H.24430.0045
36	16	14	35	58	138	26	H.24430.0050
40	20	16	40	64	152	29	H.24430.0055

