

**BOLGREEP UIT STAAL
DIN 6337**

Art. D6337.



MATERIAAL EN UITVOERING : staal, gedraaid en gepolijst, bol DIN 319 uit zwarte duroplast.

- vorm K : met rechte handgreep en boring H7,
- vorm M : met rechte handgreep en binnenschroefdraad,
- vorm L : met schuine handgreep en boring H7,
- vorm N : met schuine handgreep en binnenschroefdraad.

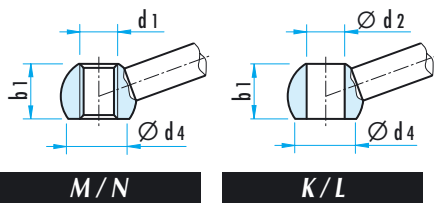

l1	M/N Ø d1	K/L Ø d2 h7	a	b1	b2	Ø d3	Ø d4	Ø d5	Ø d6	h	l2
63	M8	8	5	12	11,5	16	12,5	20	8	33	60
80	M10	10	6	14,5	14	20	16	20	9	40	76
100	M12	12	7,5	18,5	17,5	25	20	25	11	50	95
125	M16	16	10	24	23	32	25	32	15	63	119
160	M20	20	12,5	30	28,5	40	31	40	18	80	152

BESTELVOORBEELD :

Art. D6337, l1 = 80, vorm K,
= Art. D6337.080.K
Art. D6337, l1 = 125, vorm N,
= Art. D6337.125.N

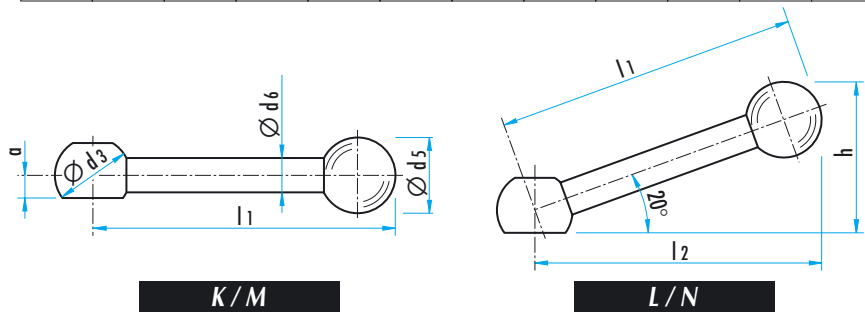

BEDIENINGSHENDEL UIT STAAL

Art. GWN.223/211



MATERIAAL EN UITVOERING : staal, gedraaid en gepolijst, bol DIN 319 uit zwart duroplast, met boring H7 : Art. GWN.223.xx.B.xx
Op aanvraag : vierkant gat, rond gat met spiegeluif.

HOGE BEDIENINGSHENDEL : Art. GWN.223

Ø d1	Ø d2 H7	Ø d3	Ø d4	h1	h2	h3	l	Art.
25	8	6	16	14	5	35	45	GWN.223.25.
32	10	8	20	18	6,5	48	62	GWN.223.32.
40	12	10	30	22	8,5	77	95	GWN.223.40.
52	16	14	40	28	11	96	136	GWN.223.52.

LAGE BEDIENINGSHENDEL : Art. GWN.211

Ø d1	Ø d2 H7	Ø d3	Ø d4	h1	h2	h3	l	Art.
50	12	8	20	17	5	45	82	GWN.211.50.
55	14	10	25	18	5	52	96	GWN.211.55.
65	16	12	30	20	5	60	110	GWN.211.65.
80	20	14	35	24	6	74	138	GWN.211.80.

