

"HEAVY DUTY" MATRIJSGASVEER

2488.13



Dit nieuwe gasverenreeks wordt ontworpen om aan de actuele grotere eisen in de dieptrek-matrijzen te beantwoorden.

Het gaat om een combinatie van de "standaard" gasveren 2480.12 / 13 en de "POWER LINE" gasveren.

Ze verbinden de kracht van de "POWER LINE" modellen met de afmetingen en de koersen van de "standaard" modellen (ISO - VDI - CNOMO).

Ze zijn voorzien met de volgende veiligheidsfuncties :

- beveiliging tegen een te hoge terugkeersnelheid
- beveiliging tegen interne overdruk
- beveiliging tegen koersoverschrijding.

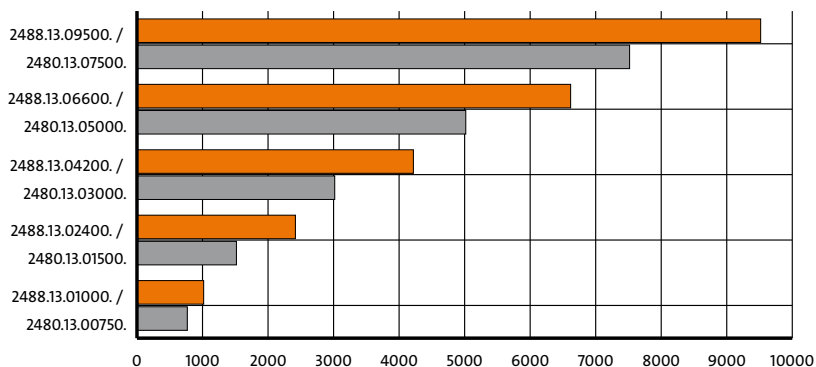

"HEAVY DUTY" MATRIJSGASVEER

2488.13.01000

2488.13.01000.

Initial spring force at 150 bar = 1000 daN

Order No	Stroke max.	l_{min}	l
2488.13.01000.013	13	108	121
025	25	120	145
038	38	133	171
050	50	145	195
063	63	158	221
075	75	170	245
080	80	175	255
100	100	195	295
125	125	220	345
150	150	245	395
160	160	255	415
175	175	270	445
200	200	295	495
250	250	345	595
300	300	395	695

2488.13.01000.

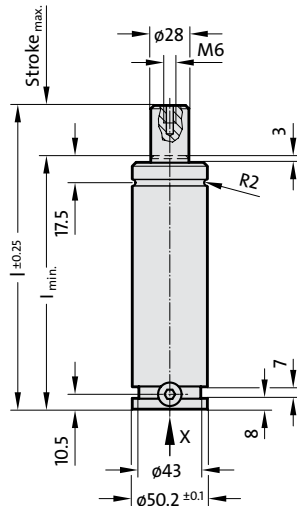

Note:

Order No for spare parts kit:
2488.13.01000

Pressure medium: Nitrogen N₂
 Max. filling pressure: 150 bar
 Min. filling pressure: 25 bar
 Working temperature: 0°C to +80°C
 Temperature related force increase: ±0.3%/°C
 Max. recommended extensions per minute: approx. 15 to 100 (at 20°C)
 Max. piston speed: 1.6 m/s

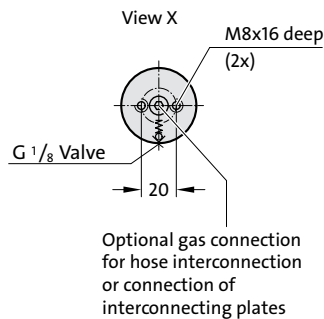

2488.13.01000.

Initial spring force versus charge pressure

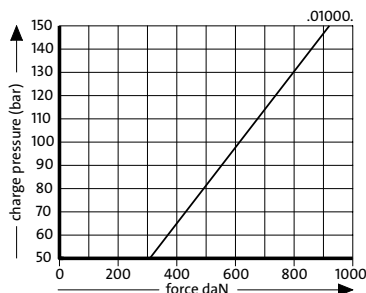

2488.13.01000.

Spring force Diagram displacement versus stroke rise

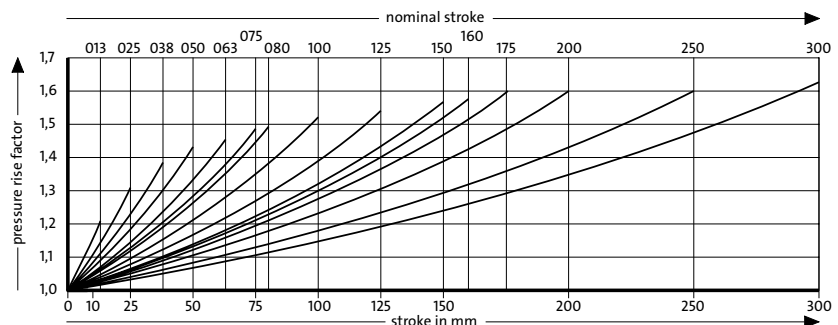

"HEAVY DUTY" MATRIJSGASVEER

2488.13.01000

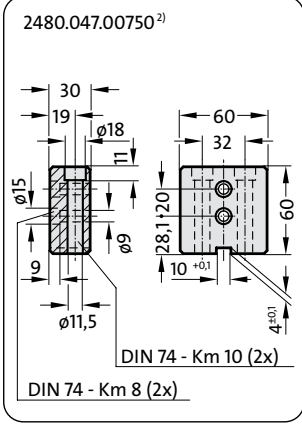
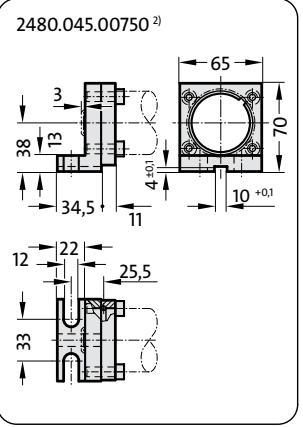
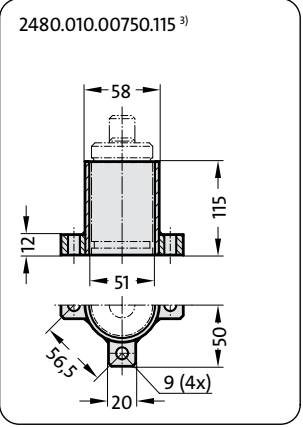
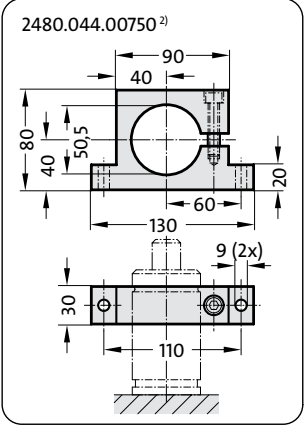
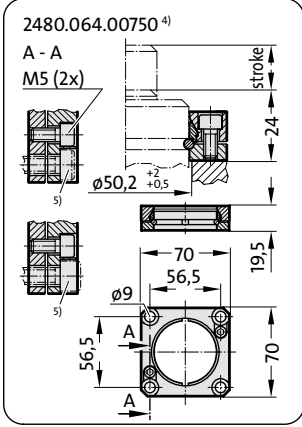
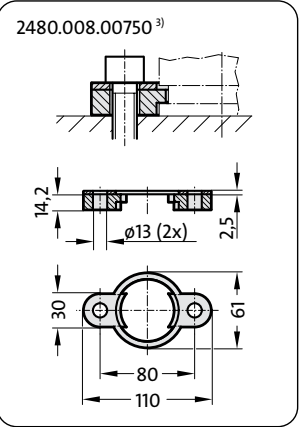
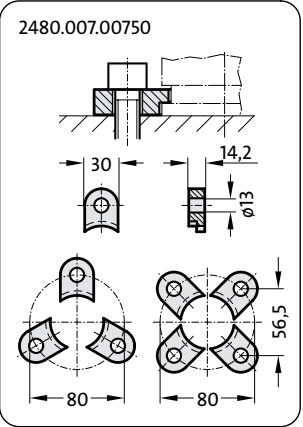
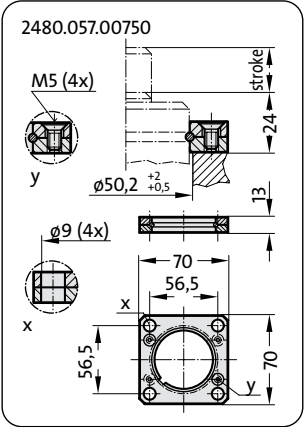
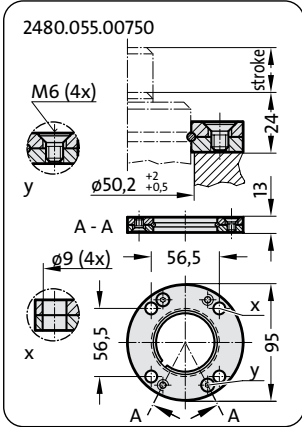
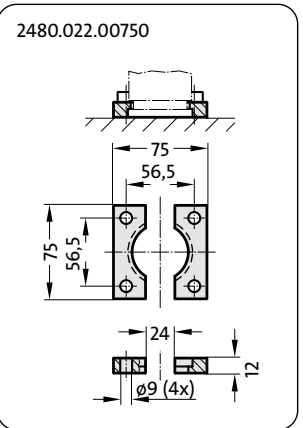
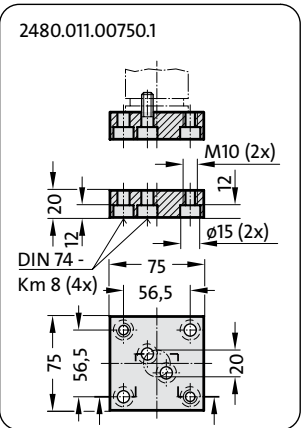
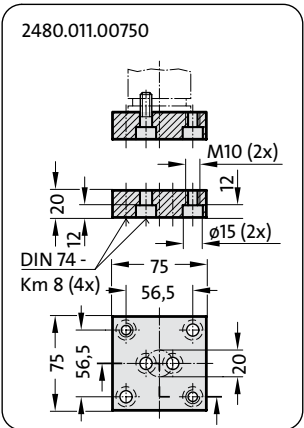
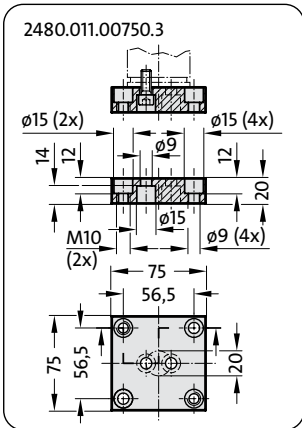

Notes:

- ²⁾ Attention:
The spring force must be absorbed by the stop surface.
- ³⁾ Not for use with composite connection.
- ⁴⁾ Square collar flange, non-rotating, fixing for composite connection.
- ⁵⁾ Machine screws with hexagonal socket (compact head recommended).

"HEAVY DUTY" MATRIJSGASVEER

2488.13.02400

2488.13.02400.

Initial spring force at 150 bar = 2400 daN

Order No	Stroke		l
	max.	l _{min}	
2488.13.02400.025	25	135	160
038	38	148	186
050	50	160	210
063	63	173	236
075	75	185	260
080	80	190	270
100	100	210	310
125	125	235	360
150	150	260	410
160	160	270	430
175	175	285	460
200	200	310	510
250	250	360	610
300	300	410	710

Note:

Order No for spare parts kit:
2488.13.02400

Pressure medium: Nitrogen N₂
 Max. filling pressure: 150 bar
 Min. filling pressure: 25 bar
 Working temperature: 0°C to +80°C
 Temperature related force increase: ±0.3%/°C
 Max. recommended extensions per minute: approx. 15 to 100 (at 20°C)
 Max. piston speed: 1.6 m/s

2488.13.02400.

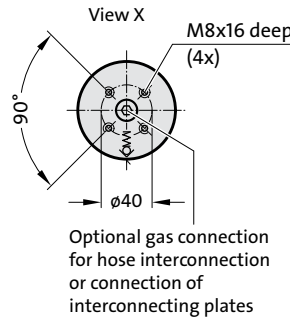
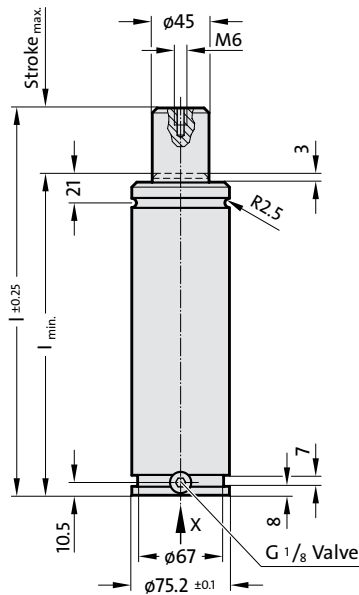

2488.13.02400.

Initial spring force versus charge pressure

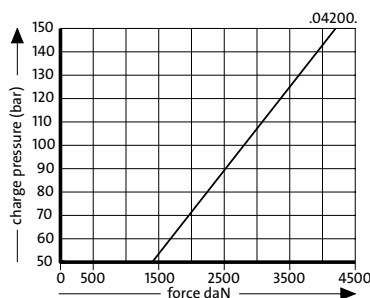

2488.13.02400.

Spring force Diagram displacement versus stroke rise

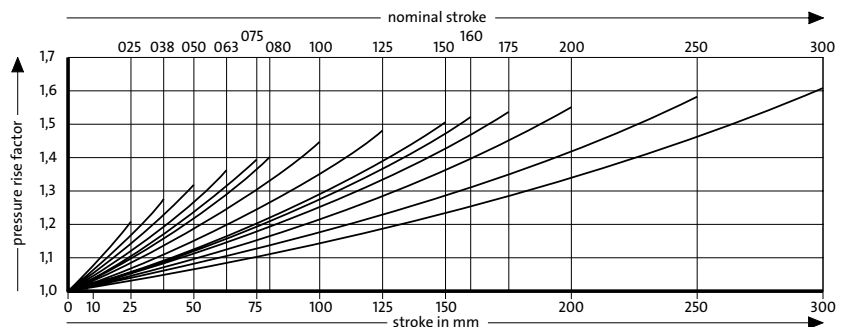

"HEAVY DUTY" MATRIJSGASVEER

2488.13.02400

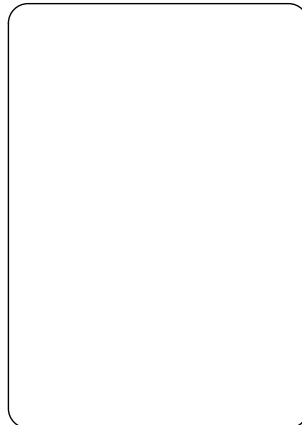
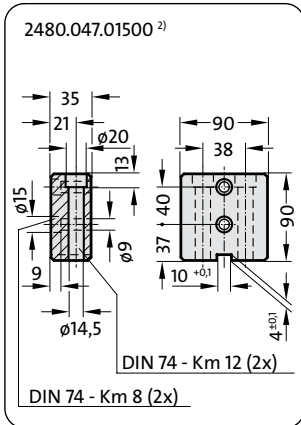
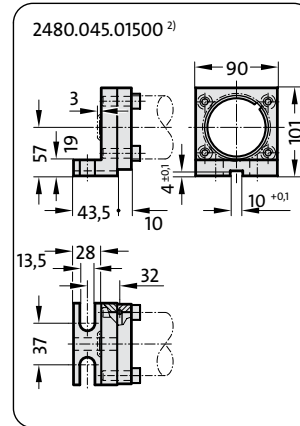
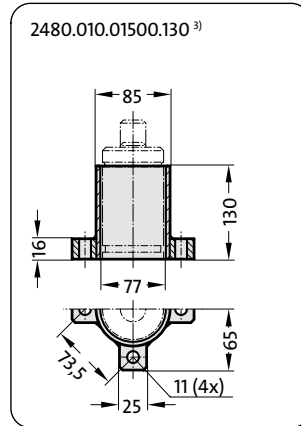
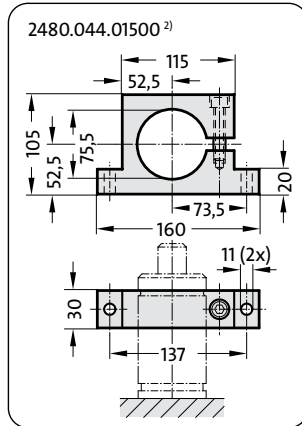
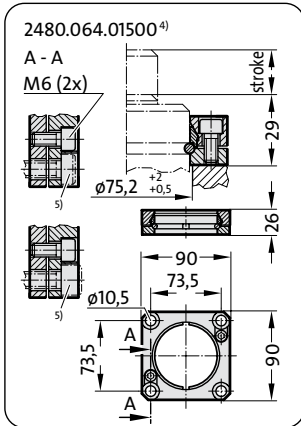
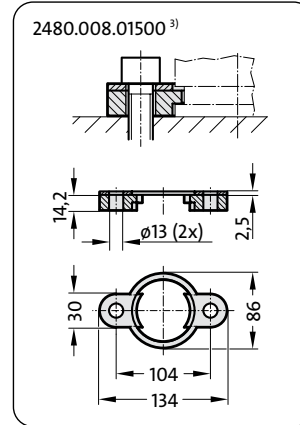
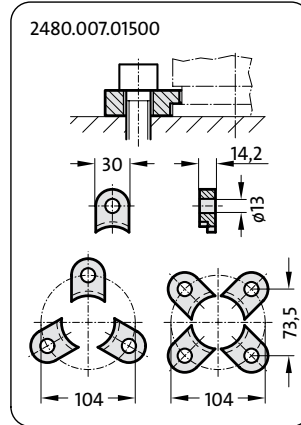
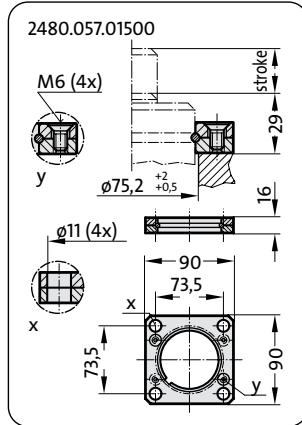
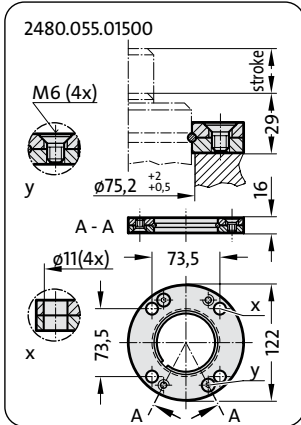
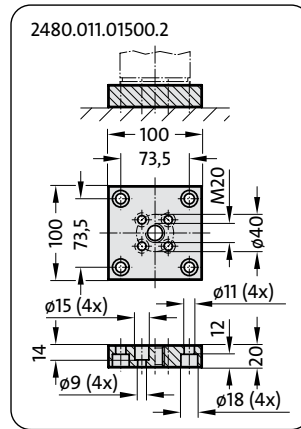
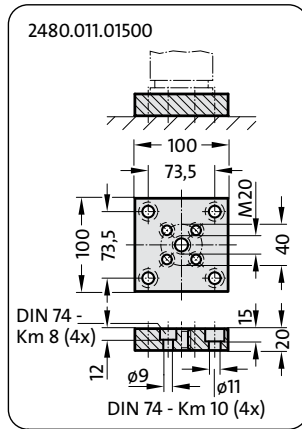
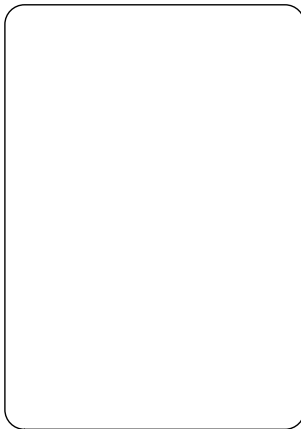

Notes:

- 2) Attention: The spring force must be absorbed by the stop surface.
- 3) Not for use with composite connection.
- 4) Square collar flange, non-rotating, fixing for composite connection.
- 5) Machine screws with hexagonal socket (compact head recommended).

"HEAVY DUTY" MATRIJSGASVEER

2488.13.04200

2488.13.04200.

Initial spring force at 150 bar = 4200 daN

Order No	Stroke max.	l_{min}	l
2488.13.04200.025	25	145	170
038	38	158	196
050	50	170	220
063	63	183	246
075	75	195	270
080	80	200	280
100	100	220	320
125	125	245	370
150	150	270	420
160	160	280	440
175	175	295	470
200	200	320	520
250	250	370	620
300	300	420	720

Note:

Order No for spare parts kit:
2488.13.04200

Pressure medium: Nitrogen N₂
 Max. filling pressure: 150 bar
 Min. filling pressure: 25 bar
 Working temperature: 0°C to +80°C
 Temperature related force increase: ±0.3%/°C
 Max. recommended extensions per minute: approx. 15 to 100 (at 20°C)
 Max. piston speed: 1.6 m/s

2488.13.04200.

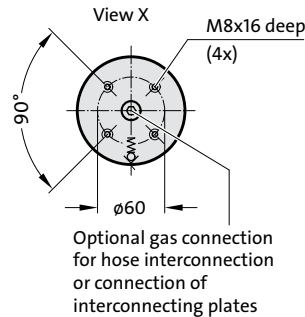
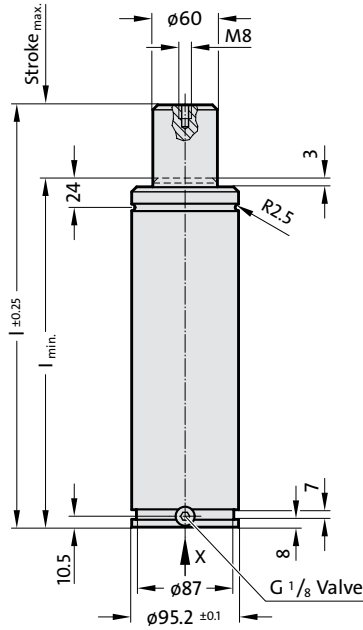

2488.13.04200.

Initial spring force versus charge pressure

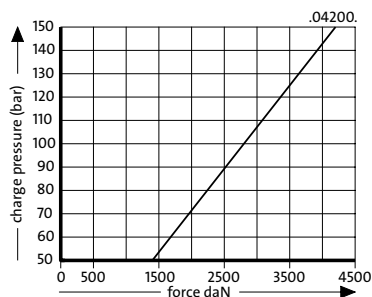

2488.13.04200.

Spring force Diagram displacement versus stroke rise

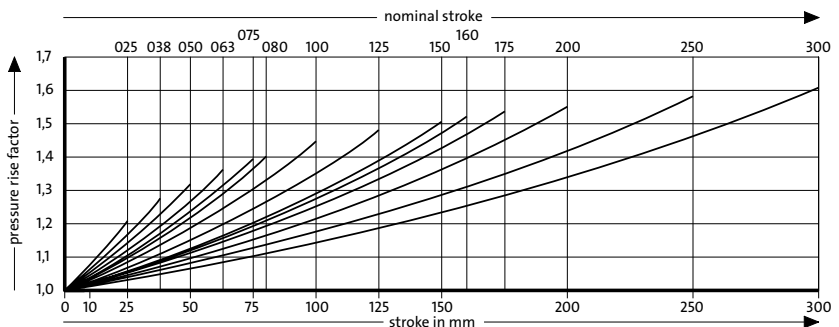

"HEAVY DUTY" MATRIJSGASVEER

2488.13.04200

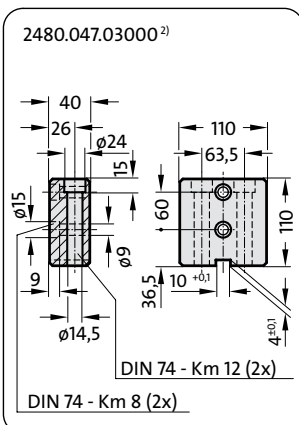
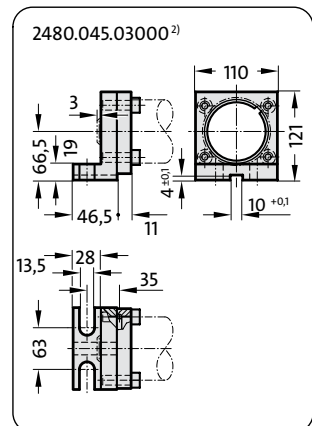
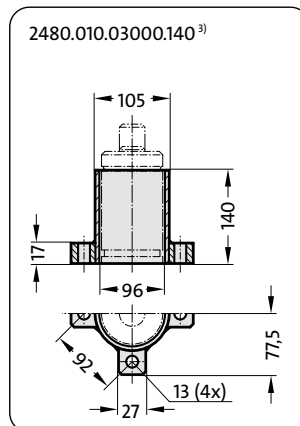
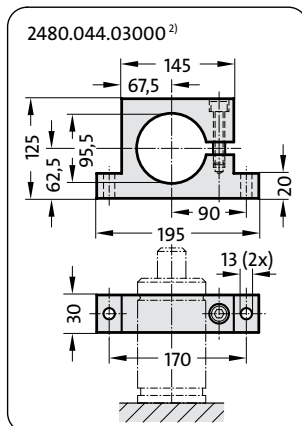
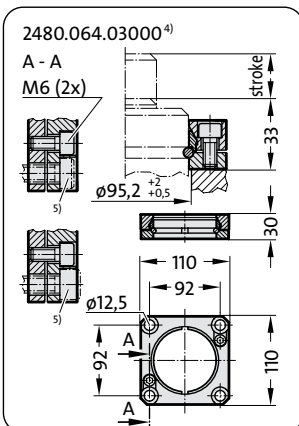
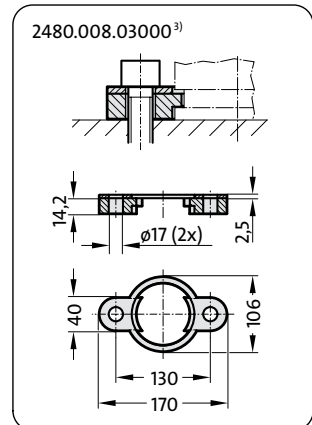
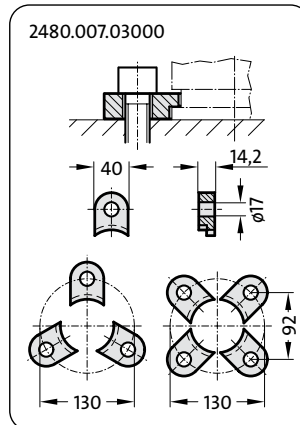
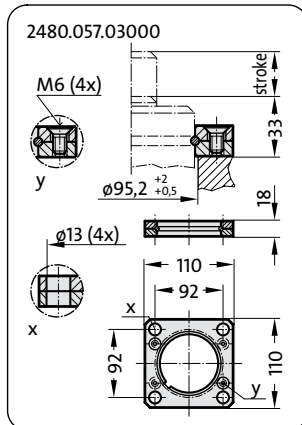
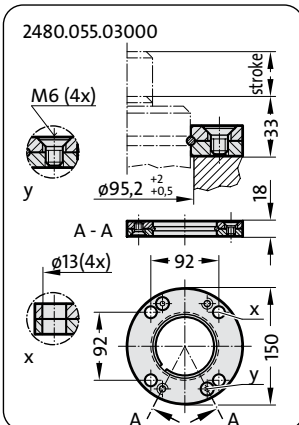
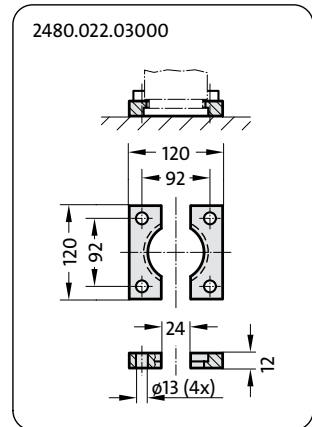
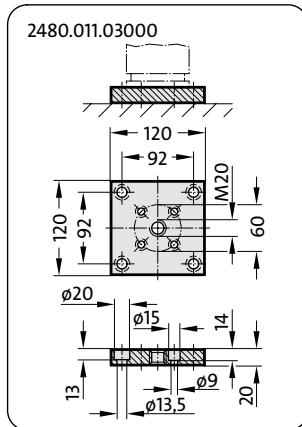
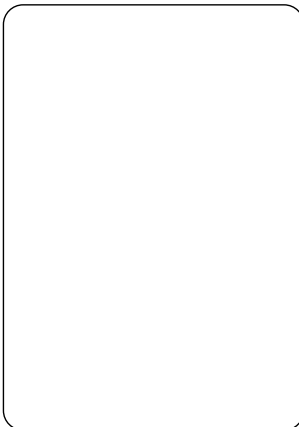

Notes:

- ²⁾ Attention: The spring force must be absorbed by the stop surface.
- ³⁾ Not for use with composite connection.
- ⁴⁾ Square collar flange, non-rotating, fixing for composite connection.
- ⁵⁾ Machine screws with hexagonal socket (compact head recommended).

"HEAVY DUTY" MATRIJSGASVEER

2488.13.06600

2488.13.06600.

Initial spring force at 150 bar = 6600 daN

Order No	Stroke max.	l_{min}	l
2488.13.06600.025	25	165	190
038	38	178	216
050	50	190	240
063	63	203	266
075	75	215	290
080	80	220	300
100	100	240	340
125	125	265	390
150	150	290	440
160	160	300	460
175	175	315	490
200	200	340	540
250	250	390	640
300	300	440	740

2488.13.06600.

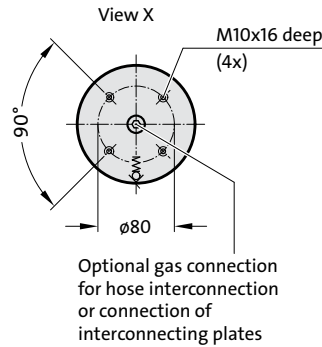
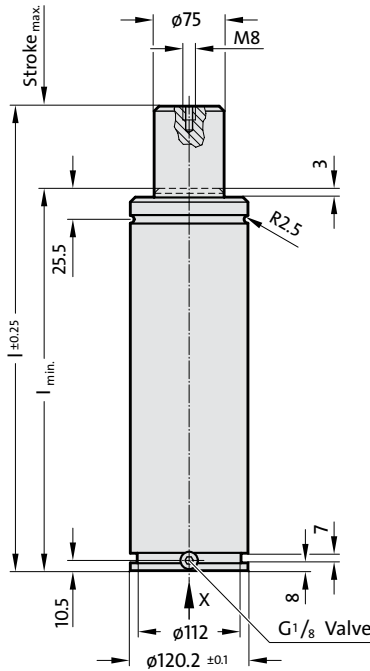

Note:

Order No for spare parts kit:
2488.13.06600

Pressure medium: Nitrogen N₂
 Max. filling pressure: 150 bar
 Min. filling pressure: 25 bar
 Working temperature: 0°C to +80°C
 Temperature related force increase: ±0.3%/°C
 Max. recommended extensions per minute: approx. 15 to 100 (at 20°C)
 Max. piston speed: 1.6 m/s

2488.13.06600.

Initial spring force versus charge pressure

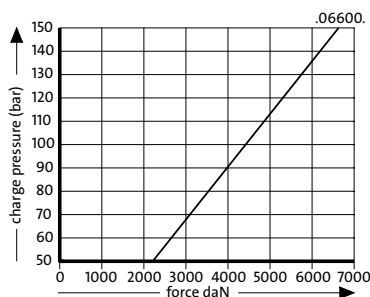

2488.13.06600.

Spring force Diagram displacement versus stroke rise

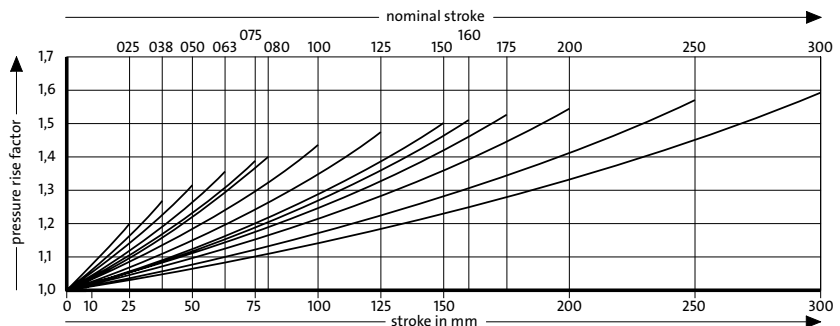

"HEAVY DUTY" MATRIJSGASVEER

2488.13.06600

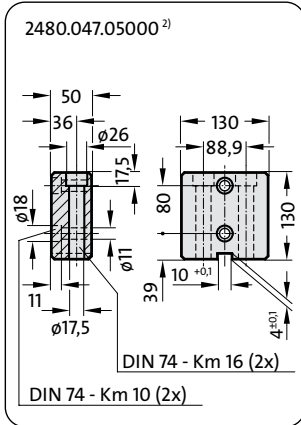
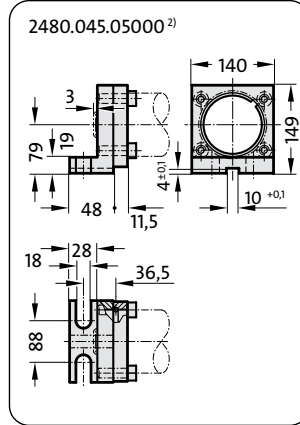
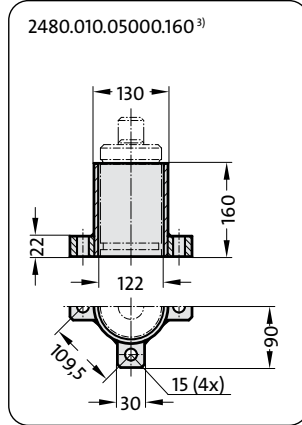
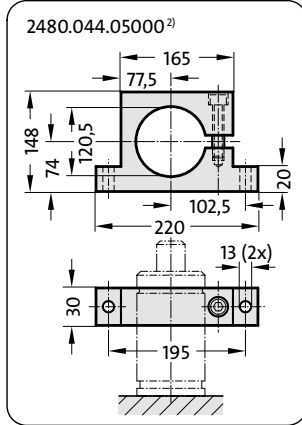
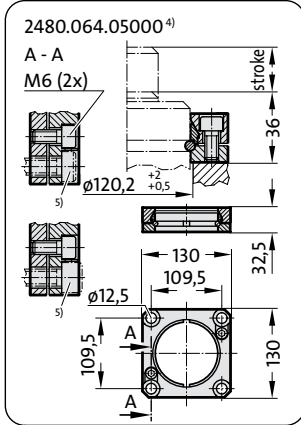
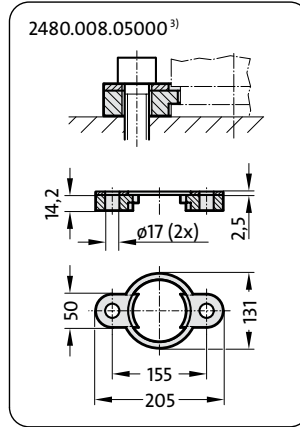
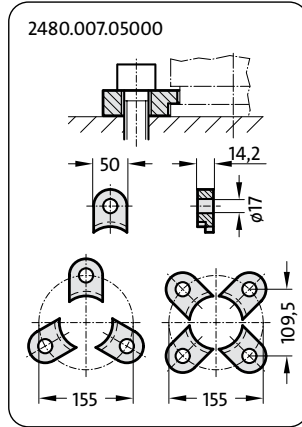
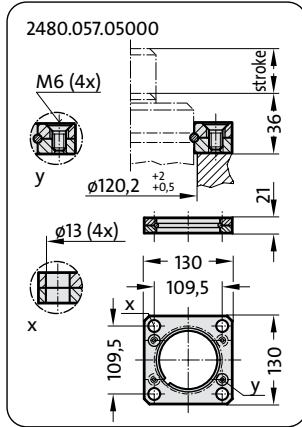
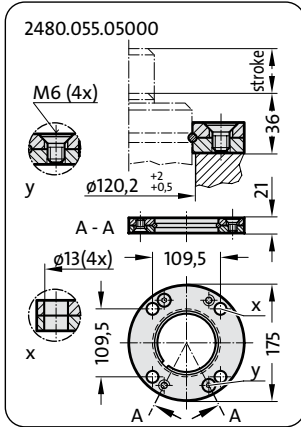
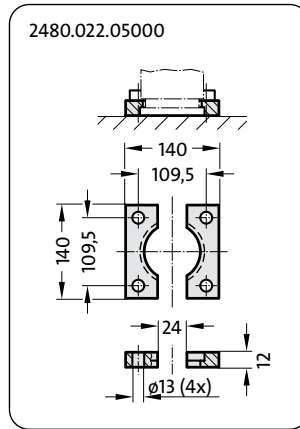
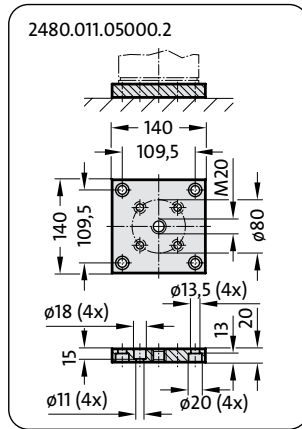
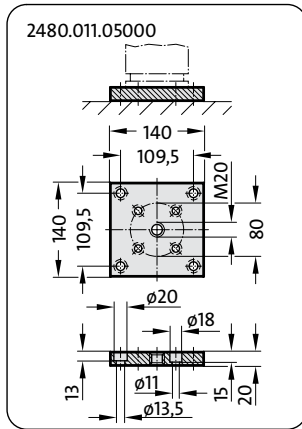

Notes:

- ²⁾ Attention:
The spring force must be absorbed by the stop surface.
- ³⁾ Not for use with composite connection.
- ⁴⁾ Square collar flange, non-rotating, fixing for composite connection.
- ⁵⁾ Machine screws with hexagonal socket (compact head recommended).

"HEAVY DUTY" MATRIJSGASVEER

2488.13.09500

2488.13.09500.

Initial spring force at 150 bar = 9500 daN

Order No	Stroke		
	max.	l_{min}	l
2488.13.09500.025	25	180	205
038	38	193	231
050	50	205	255
063	63	218	281
075	75	230	305
080	80	235	315
100	100	255	355
125	125	280	405
150	150	305	455
160	160	315	475
175	175	330	505
200	200	355	555
250	250	405	655
300	300	455	755

Note:

Order No for spare parts kit:
2488.13.09500

Pressure medium: Nitrogen N₂
 Max. filling pressure: 150 bar
 Min. filling pressure: 25 bar
 Working temperature: 0°C to +80°C
 Temperature related force increase: ±0.3%/°C
 Max. recommended extensions per minute: approx. 15 to 100 (at 20°C)
 Max. piston speed: 1.6 m/s

2488.13.09500.

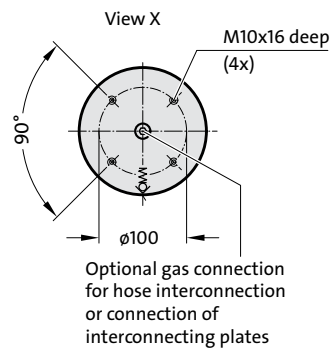
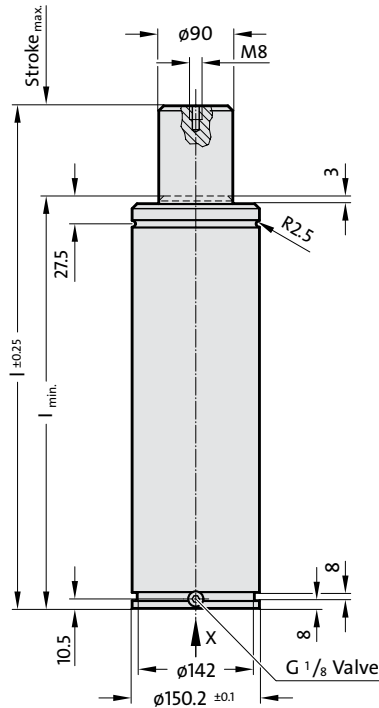

2488.13.09500.

Initial spring force versus charge pressure

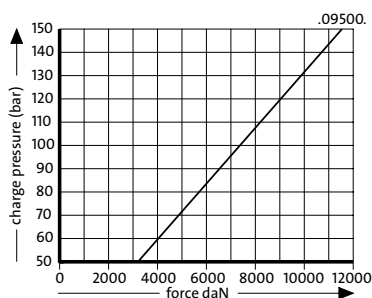

2488.13.09500.

Spring force Diagram displacement versus stroke rise

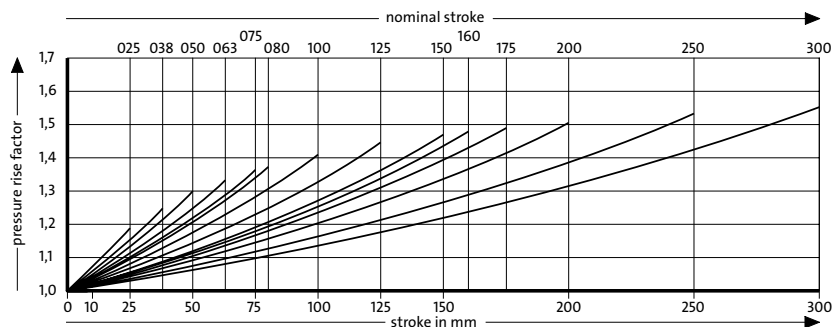

"HEAVY DUTY" MATRIJSGASVEER

2488.13.09500

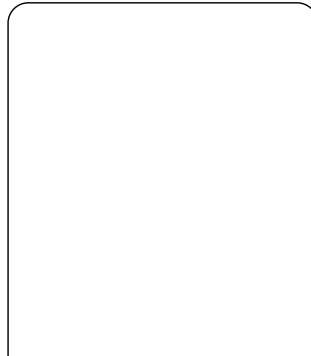
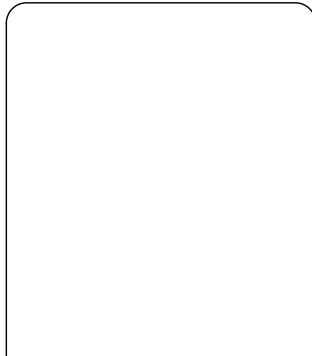
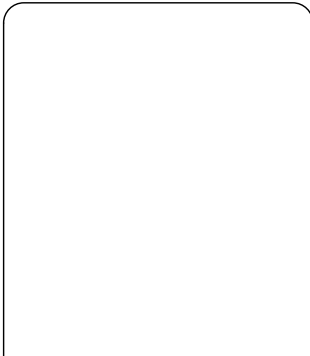
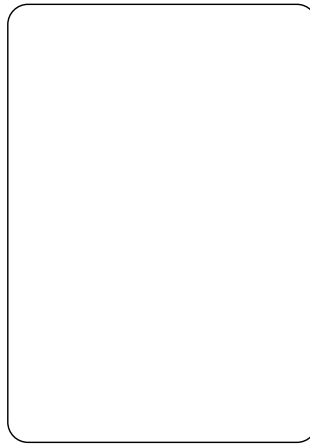
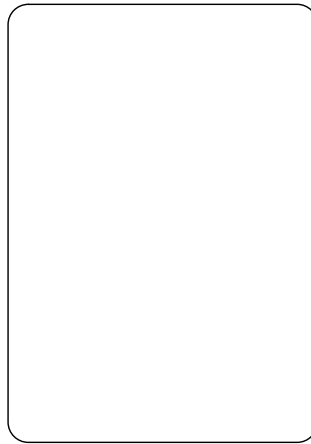
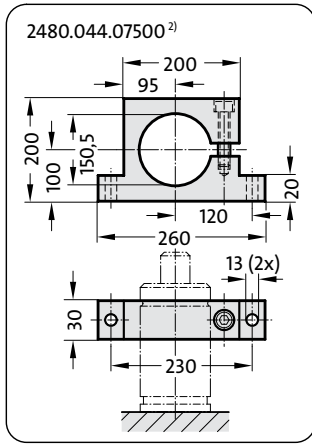
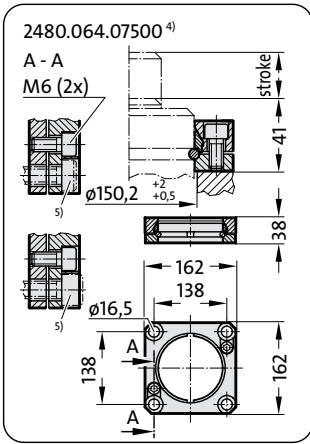
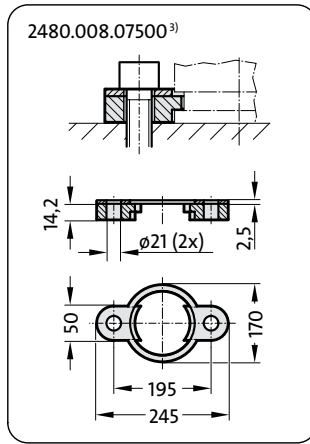
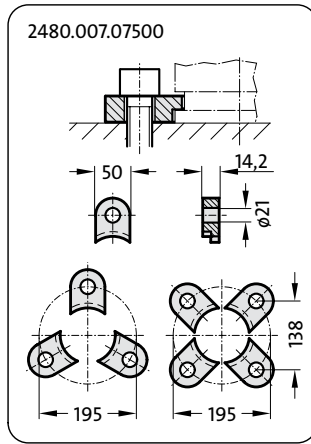
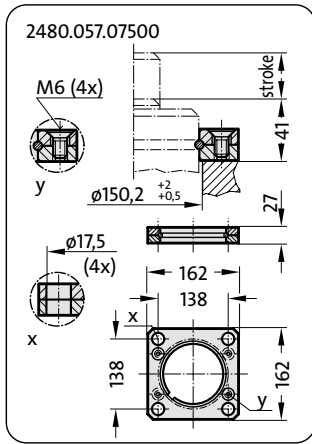
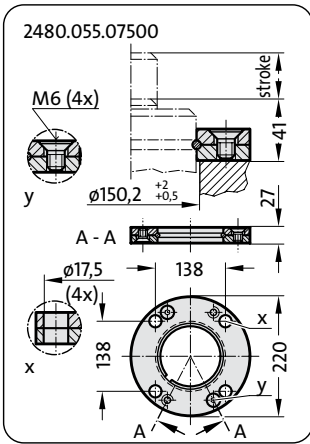
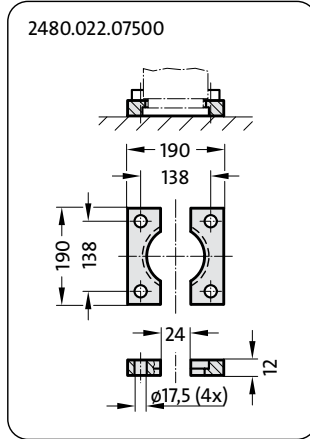
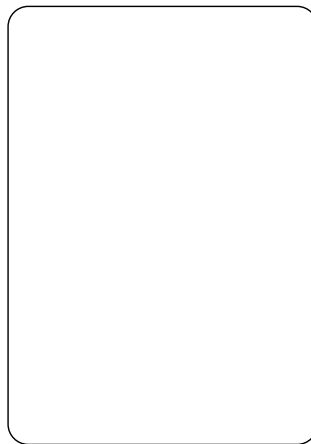
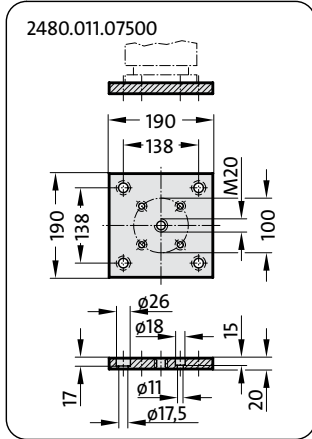
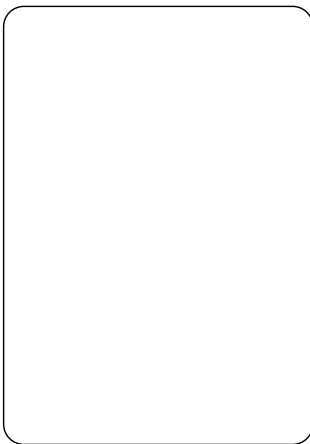

Notes:

- 2) Attention:
The spring force must be absorbed by the stop surface.
- 3) Not for use with composite connection.
- 4) Square collar flange, non-rotating, fixing for composite connection.
- 5) Machine screws with hexagonal socket (compact head recommended).