

**OPSPANTAP
ISO 10242 - DIN 9859**

Art. 211.11 / 12 / 13

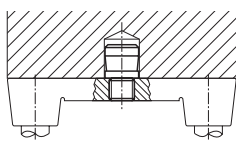

Art. 211.12

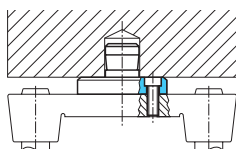

Art. 211.14

De meeste persen zijn uitgerust met een boring in de drukstang volgens DIN 810.
De kleine en middelgrote werktuigen worden met opspantappen volgens DIN 9859 op de pers bevestigd.

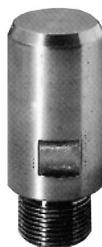

Art. 211.11



Art. 211.12



Art. 211.13

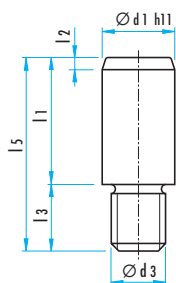

Art. 211.11

d1	d3	l1	l2	l3	l5	Art.
20	M16 x 1,5	40	3	18	58	211.11.20.016
25	M16 x 1,5	45	4	23	68	211.11.25.016
25	M20 x 1,5	45	4	23	68	211.11.25.020
32	M20 x 1,5	56	4	23	79	211.11.32.020
32	M24 x 1,5	56	4	23	79	211.11.32.024
40	M24 x 1,5	70	5	23	93	211.11.40.024
40	M30 x 2	70	5	23	93	211.11.40.030
50	M30 x 2	80	6	28	108	211.11.50.030
65	M42 x 3	100	8	28	128	211.11.65.042

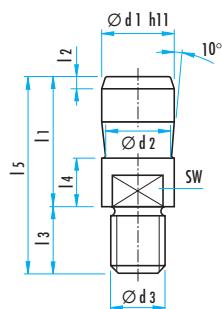

Art. 211.12

d1	d2	d3	l1	l2	l3	l4	l5	SW	Art.
20	15	M16 x 1,5	40	3	18	12	58	17	211.12.20.016
25	20	M16 x 1,5	45	4	23	16	68	21	211.12.25.016
25	20	M20 x 1,5	45	4	23	16	68	21	211.12.25.020
32	25	M20 x 1,5	56	4	23	16	79	27	211.12.32.020
32	25	M24 x 1,5	56	4	23	16	79	27	211.12.32.024
40	32	M24 x 1,5	70	5	23	26	93	36	211.12.40.024
40	32	M30 x 2	70	5	23	26	93	36	211.12.40.030
50	42	M30 x 2	80	6	28	26	108	41	211.12.50.030
65	53	M42 x 3	100	8	28	26	128	55	211.12.65.042

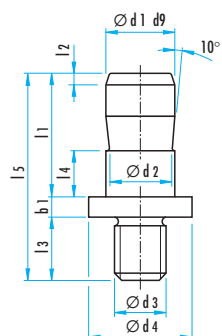

Art. 211.13

d1	d2	d3	d4	b1	l1	l2	l3	l4	l5	Art.
20	15	M16 x 1,5	28	5	40	3	16	12	61	211.13.20.016
25	20	M16 x 1,5	34	5	45	4	16	16	66	211.13.25.016
25	20	M20 x 1,5	34	5	45	4	20	16	70	211.13.25.020
32	25	M20 x 1,5	42	6	56	4	20	16	82	211.13.32.020
32	25	M24 x 1,5	42	6	56	4	24	16	86	211.13.32.024
40	32	M24 x 1,5	52	8	70	5	24	26	102	211.13.40.024
40	32	M30 x 2	52	8	70	5	30	26	108	211.13.40.030
50	42	M30 x 2	62	8	80	6	30	26	118	211.13.50.030

TOEBEHOREN VOOR ZUILENBLOKKEN

Art. 211.14 - 212.11/15



OPSPANTAP - ISO 10242 - DIN 9859

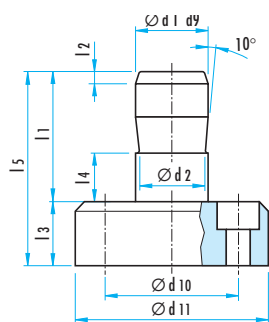

Art. 211.14

d1	d2	d10	d11	l1	l2	l3	l4	l5	Art.
20	15	45	63	40	3	18	12	58	211.14.20.063
25	20	45	63	45	4	18	16	63	211.14.25.063
25	20	63	80	45	4	18	16	63	211.14.25.080
32	25	80	97	56	4	23	16	79	211.14.32.097
32	25	105	122	56	4	23	16	79	211.14.32.122
40	32	80	97	70	5	23	26	93	211.14.40.097
40	32	105	122	70	5	23	26	93	211.14.40.122

KOPPELINGSTAP

Noodzakelijk bij snel of regelmatig omwisselen van werktuigen.
De pers moet uitgerust zijn met een opnamevoet.

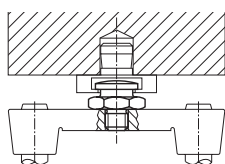

Art. 212.11



Art. 212.11



Art. 212.15

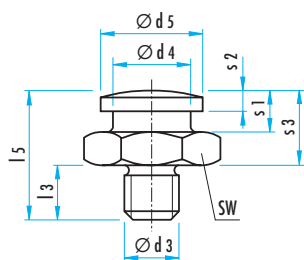

Art. 212.11

KOPPELINGSTAP MET SCHROEFDRAAD

sw	d3	d4	d5	l3	l5	s1	s2	s3	Art.
36	M16 x 1,5	25	32	18	41	13	6,5	23	212.11.016
50	M20 x 1,5	32	48	23	64	19	9,5	41	212.11.020
50	M24 x 1,5	32	48	23	64	19	9,5	41	212.11.024
60	M30 x 2	32	48	23	66	19	9,5	43	212.11.030

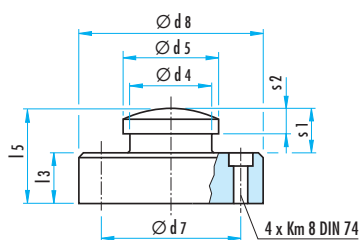

Art. 212.15

KOPPELINGSTAP MET FLENS

d4	d5	d7	d8	l3	l5	s1	s2	Art.
25	32	46	63	18	31	13	6,5	212.15.063
32	48	63	80	18	37	19	9,5	212.15.080
32	48	80	97	23	42	19	9,5	212.15.097
32	48	105	122	23	42	19	9,5	212.15.122

TOEBEHOREN VOOR ZUILENBLOKKEN

Art. 212.16 - 213.12

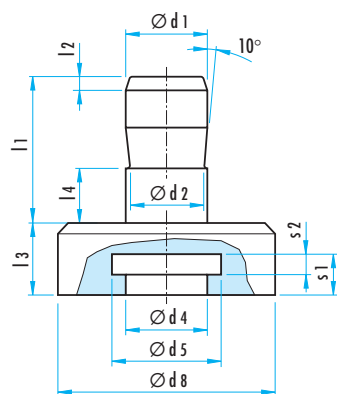

Art. 212.16



Art. 212.16



Art. 213.12

OPNAMEVOET VOOR KOPPELINGSTAP

d1	d2	d4	d5	d8	l1	l2	l3	l4	s1	s2	Art.
25	20	26	33	56	45	4	25	16	12,6	7	212.16.025
32	25	33	49	80	56	4	30	16	18,6	10	212.16.032
40	32	33	49	80	70	5	30	26	18,6	10	212.16.040

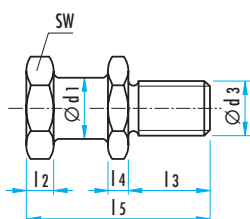

Art. 213.12

DRAAGSCHROEF

d1	d3	l2	l3	l4	l5	sw	(daN)	Art.
16	M16	6	22	6	50	27	400	213.12.016
20	M20	8	25	7	60	32	500	213.12.020
25	M24	10	32	8	75	36	630	213.12.024
30	M30	12	40	10	94	41	1000	213.12.030
36	M36	12	50	10	112	50	1600	213.12.036

VERBINDINGSTAP VOOR KLEINE PERSEN

Art. 212.16.1

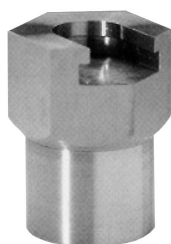

OPMERKING : de schroefdraadgrootte m1 en schroefdraadlengte l5 worden gemaakt volgens de cilinderstang en naar wens van de gebruiker. Ook combineerbaar met opspantappen Art.212.11 en 212.15 (zie pag. 809).

d4	d5	d8	SW	l1	l2	l5	M	s1	s2	Art.
26	33	45	50	70	57,4	naar keuze		12,6	7	212.16.1.026
33	49	60	65	86	67,4			18,6	10	212.16.1.033

