

**GELEIDINGSLAT
VDI 3357**

Art. 2962.75

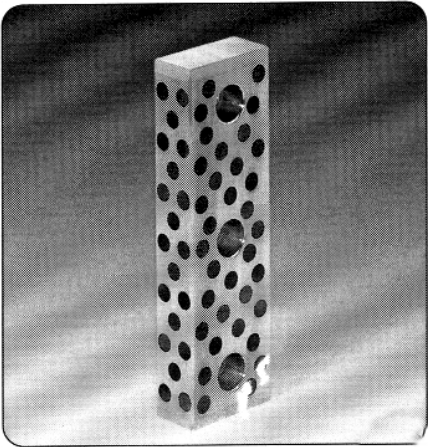
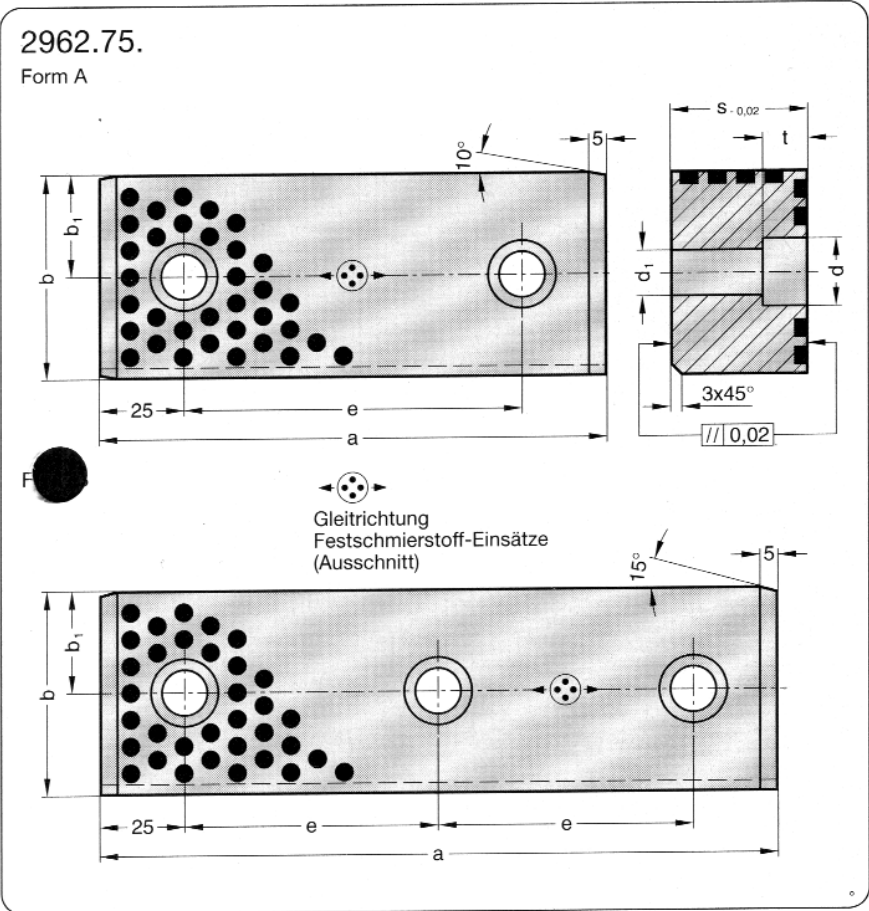

Werkstoff:
Bronze mit Festschmierstoff, wartungsarm.

Befestigung:
Zylinderschrauben DIN EN ISO 4762
M 8×20
M10×25
M12×35
M12×45 verwenden.

2962.75.

Bestell-Nr.	Form	a	b	s	b ₁	e	d	d ₁	t	Anzahl Bohrungen
2962.75.025.012.0110	A	110	25	12	12,5	60	15	9	8,5	2
0120		120				70				
2962.75.025.015.0110	A	110	25	15	12,5	60	18	11	10,5	2
0120		120				70				
2962.75.060.030.0125	A	125	60	30	30	75	20	13,5	13	2
0150		150				100				
0160		160				110				
0200	B	200				75				
2962.75.060.040.0125	A	125	60	40	30	75	20	13,5	13	2
0150		150				100				
0160		160				110				
0200	B	200				75				3

Bestell-Beispiel:

Führungsleiste = 2962.75.
 $b = 60$ mm = 060.
 $s = 30$ mm = 030.
 $a = 200$ mm = 0200
 Bestell-Nummer = 2962.75.060.030.0200

GELEIDINGSLAT

Art. 2962.76

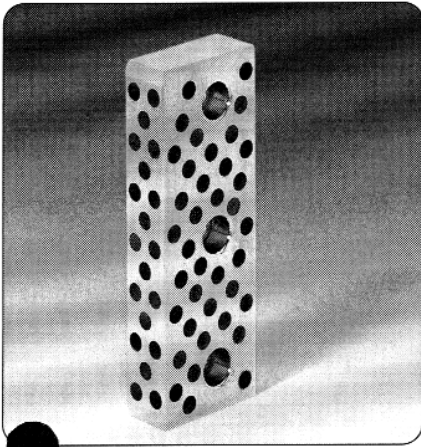

Werkstoff:
 Bronze mit Festschmierstoff, wartungsarm.

Hinweis:
 Lieferung ohne Schrauben.

Befestigung:
 Zylinderschrauben
 DIN EN ISO 4762 verwenden.
 2962.76.070. M12
 2962.76.090. M16

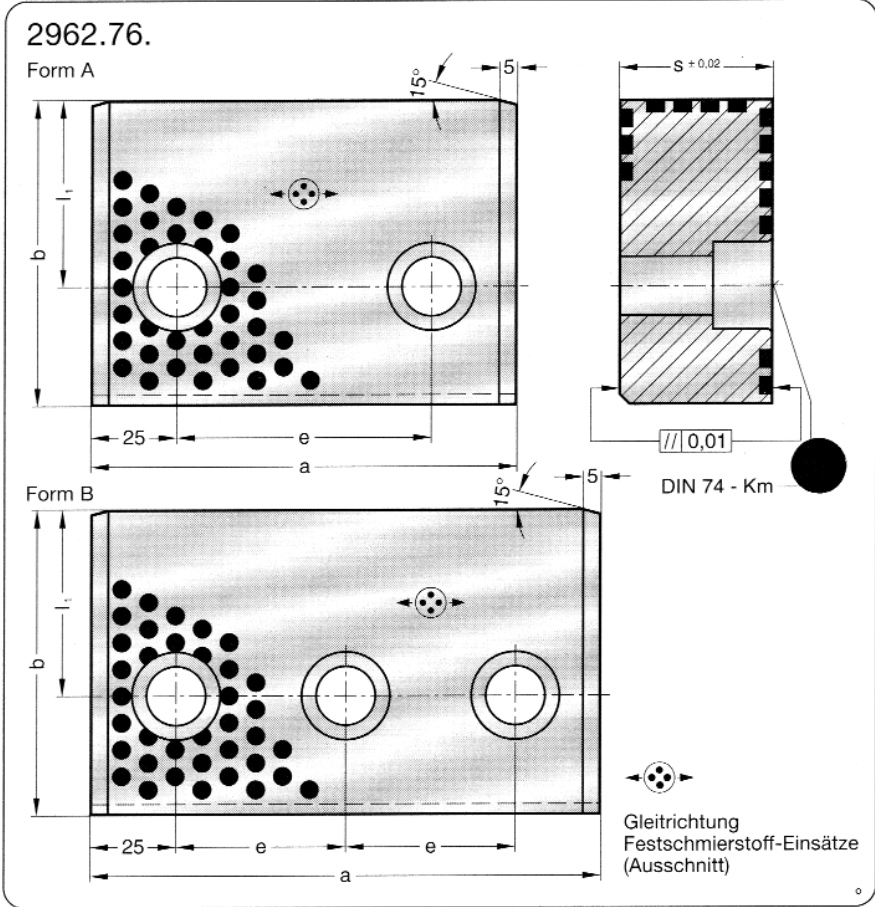

2962.76.

Bestell-Nr.	Form	a	b	s	e	l ₁	DIN 74 Km	Anzahl Bohrungen
2962.76.070.032.0125	A	125	70	32	75	40	12	2
0150	A	150	70	32	100	40	12	2
0200	B	200	70	32	75	40	12	3
2962.76.090.045.0125	A	125	90	45	75	55	16	2
0150	B	150	90	45	50	55	16	3
0200	B	200	90	45	75	55	16	3

Bestell-Beispiel:

Führungsleiste = 2962.76.
 b = 70 mm = 070.
 s = 32 mm = 032.
 a = 200 mm = 0200
 Bestell-Nummer = 2962.76.070.032.0200

GELEIDINGSLAT

Art. 2962.77

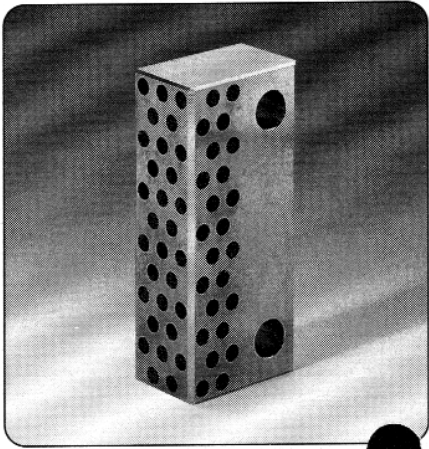
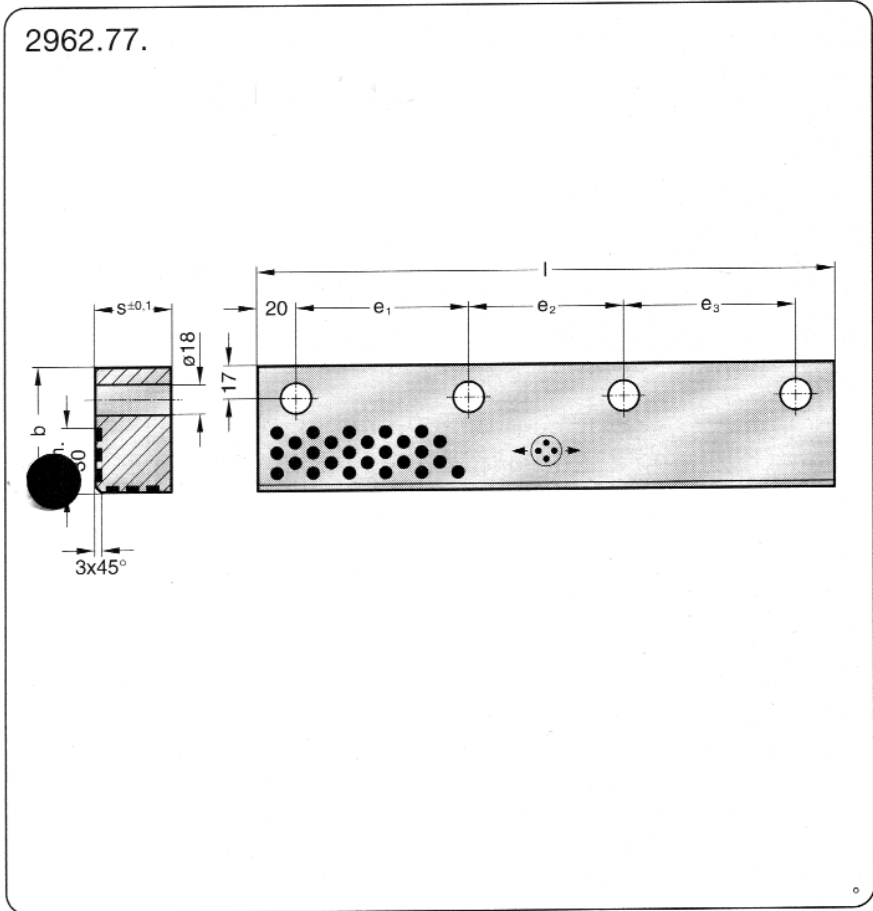

Werkstoff:
Bronze mit Festschmierstoff, wartungsarm.

Hinweis:
Lieferung ohne Schrauben.

Gleitrichtung
Festschmierstoff-Einsätze
(Ausschnitt)

2962.77.

Bestell-Nr.	b	s	l	e ₁	e ₂	e ₃	Anzahl Bohrungen
2962.77.065.040.0150	65	40	150	110	-	-	2
0200			200	80	80	-	3
0250			250	105	105	-	3
0300			300	90	80	90	4
0350			350	105	100	105	4
2962.77.065.065.0150	65	65	150	110	-	-	2
0200			200	80	80	-	3
0250			250	105	105	-	3
0300			300	90	80	90	4
0350			350	105	100	105	4

Bestell-Beispiel:

Führungsleiste = 2962.77.
 b = 65 mm = 065.
 s = 40 mm = 040.
 l = 250 mm = 0250
 Bestell-Nummer = 2962.77.065.040.0250

GELEIDINGSLAT

Art. 2962.74

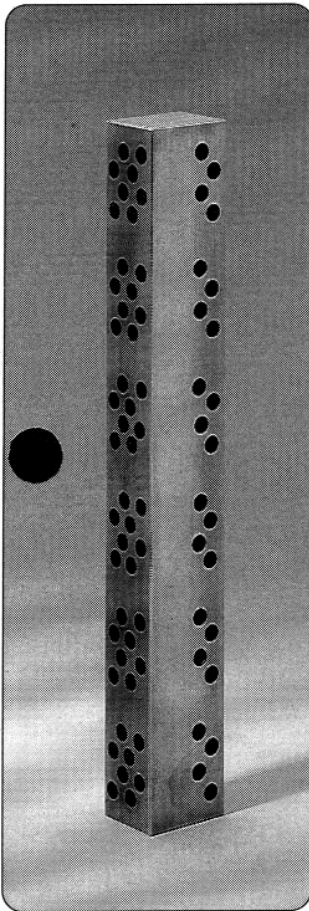

2962.74.

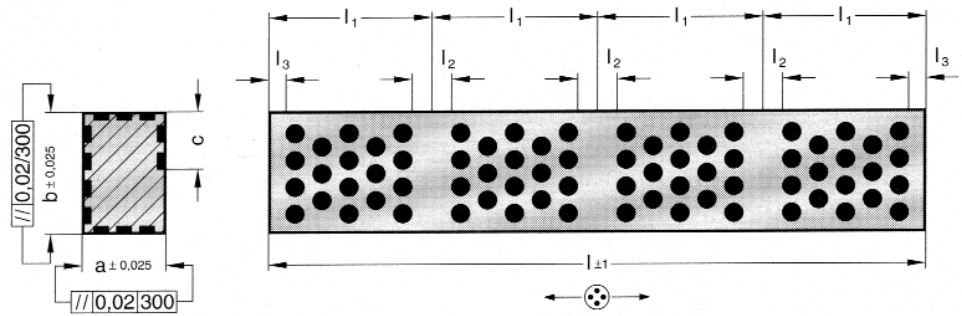

Flächen ohne Festschmierstoff: umlaufend

Werkstoff:

Bronze mit Festschmierstoff, wartungsarm.



Gleitrichtung
Festschmierstoff-Einsätze
(Ausschnitt)

2962.74.

Bestell-Nr.	a	b	c	l	l ₁	l ₂	l ₃
2962.74.015.010.075	10,3	15,3	6	75	25	6	3
100				100			
125				125			
150				150			
175				175			
200				200			
225				225			
250				250			
275				275			
300				300			
2962.74.025.015.105	15,3	25,3	8	105	35	8	4
140				140			
175				175			
210				210			
245				245			
280				280			
315				315			
350				350			
385				385			
420				420			
455				455			
490				490			
2962.74.035.025.135	25,3	35,3	12	135	45	10	5
180				180			
225				225			
270				270			
315				315			
360				360			
405				405			
450				450			
495				495			
2962.74.045.035.165	35,3	45,3	16	165	55	12	6
220				220			
275				275			
330				330			
385				385			
440				440			
495				495			

Bestell-Beispiel:

Führungsleiste = 2962.74.
 b = 25,3 mm = 025.
 a = 15,3 mm = 015.
 l = 105 mm = 105
 Bestell-Nummer = 2962.74.025.015.105

GELEIDINGSLAT

Art. 2962.79

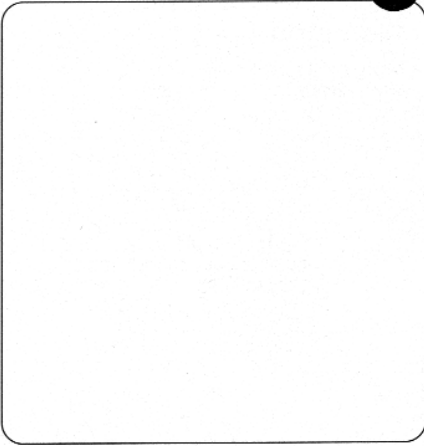
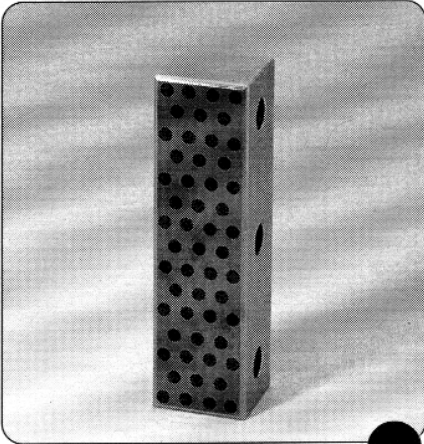
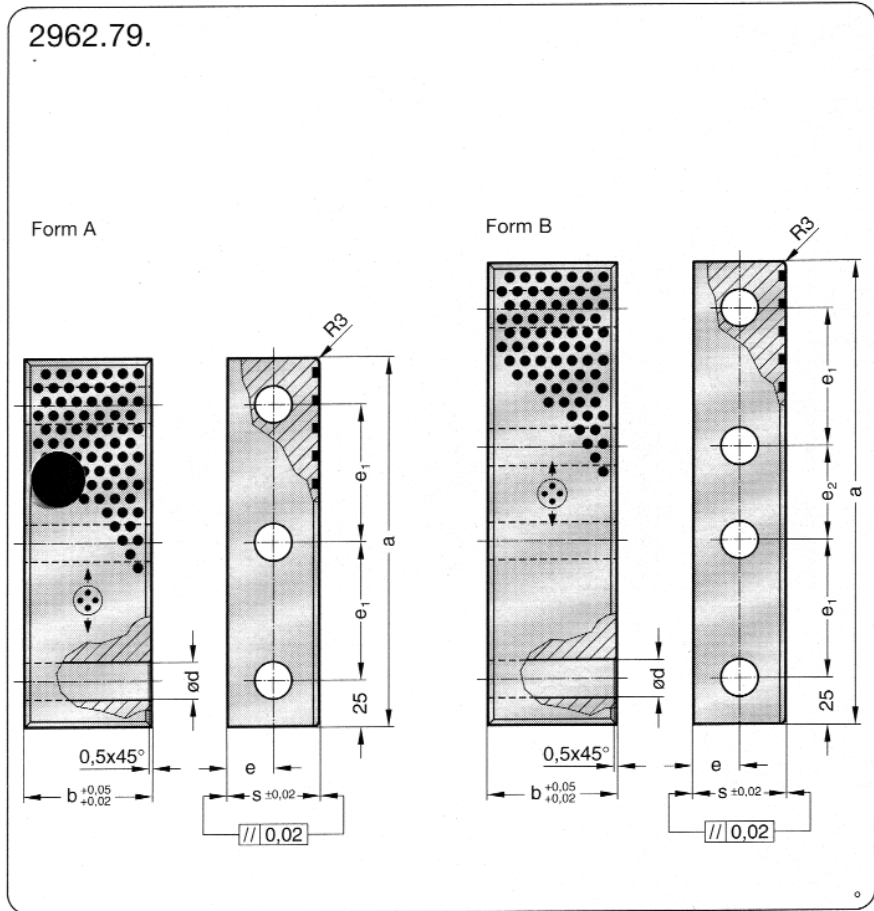

2962.79.

Bestell-Nr.	Form	b	s	a	e	e ₁	e ₂	d	Anzahl Bohrungen
2962.79.030.040.150	A	30	40	150	20	50	-	14	3
200	A			200		75	-		3
250	B			250		75	50		4
2962.79.040.040.150	A	40	40	150	20	50	-	14	3
200	A			200		75	-		3
250	B			250		75	50		4
2962.79.045.050.150	A	45	50	150	25	50	-	18	3
200	A			200		75	-		3
250	B			250		75	50		4
2962.79.055.050.150	A	55	50	150	25	50	-	18	3
200	A			200		75	-		3
250	B			250		75	50		4
2962.79.060.050.150	A	60	50	150	25	50	-	18	3
200	A			200		75	-		3
250	B			250		75	50		4
2962.79.070.050.150	A	70	50	150	25	50	-	18	3
200	A			200		75	-		3
250	B			250		75	50		4

Beschreibung:

Führungsleisten werden bevorzugt in Großwerkzeugen mit großer Flächen-
 druckung eingesetzt.
 Bronze mit eingelagertem Festschmierstoff
 gewährleistet einen wartungs-
 armen Einsatz, auch im Dauerbetrieb.

Werkstoff:

Bronze mit Festschmierstoff,
 wartungsarm.

Hinweis:

Lieferung ohne Schrauben.

Bestell-Beispiel:

Führungsleiste	=	2962.79.
b = 40 mm	=	040.
s = 40 mm	=	040.
a = 150 mm	=	150
Bestell-Nummer	=	2962.79.040.040.150

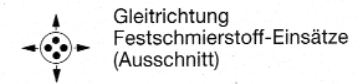

GELEIDINGSLAT

Art. 2962.80

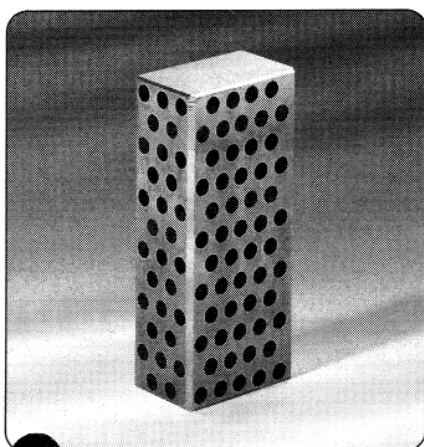

2962.80.

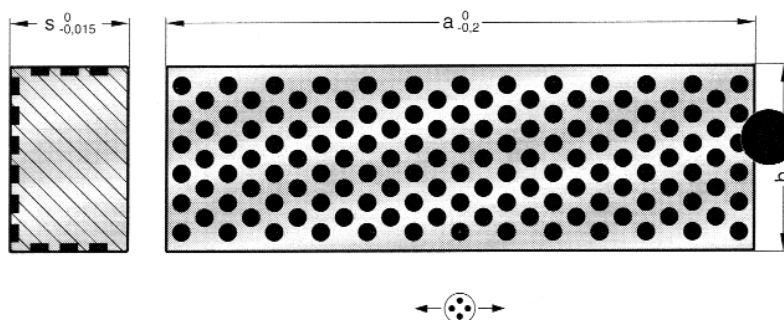

Werkstoff:

Bronze mit Festschmierstoff, wartungsarm.



Gleichrichtung
Festschmierstoff-Einsätze
(Ausschnitt)

2962.80.

Bestell-Nr.	b	s	l
2962.80.025.016.080	25	16	80
100			100
125			125
2962.80.040.025.125	40	25	125
160			160
200			200
2962.80.063.040.200	63	40	200
250			250
315			315

Bestell-Beispiel:

Führungsleiste = 2962.80.
 b = 25 mm = 025.
 s = 16 mm = 016.
 l = 80 mm = 080
 Bestell-Nr. = 2962.80.025.016.080