

**GELEIDINGSSTUK BRONS OF STAAL
"NAAMS"**

Art. 2963.82/83

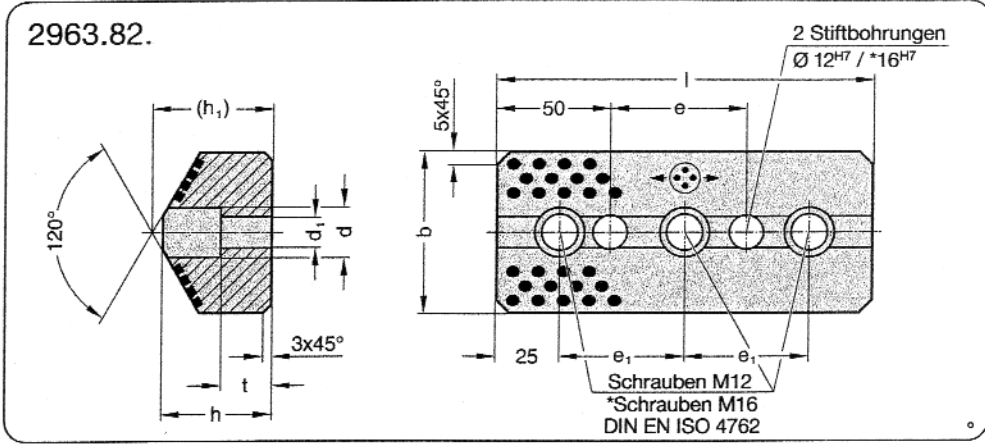
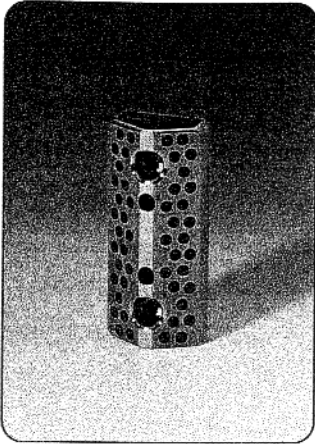

2963.82.

Bestell-Nr.	b	h	(h ₁)	l	e	e ₁	d	d ₁	t	Anzahl Schrauben
2963.82.065.039.0150	65	39	(42)	150	50	100	20	13,5	13	2
0200				200	100	150				2
0250				250	150	100				3
0300				300	200	125				3
2963.82.075.039.0150	75	39	(42)	150	50	100	20	13,5	13	2
0200				200	100	150				2
0250				250	150	100				3
0300				300	200	125				3
2963.82.125.052.0150*	125	52	(57)	150	50	100	20	17,5	15	2
0200*				200	100	150				2
0250*				250	150	100				3
0300*				300	200	125				3

Werkstoff:
Bronze mit Festschmierstoff, wartungsarm.

Ausführung:
Gleitflächen geschliffen

Hinweis:
Lieferung ohne Schrauben und Stifte.

Bestell-Beispiel:

Gleitstück = 2963.82.
b = 65 mm = 065.
h = 39 mm = 039.
l = 200 mm = 0200
Bestell-Nr. = 2963.82.065.039.0200

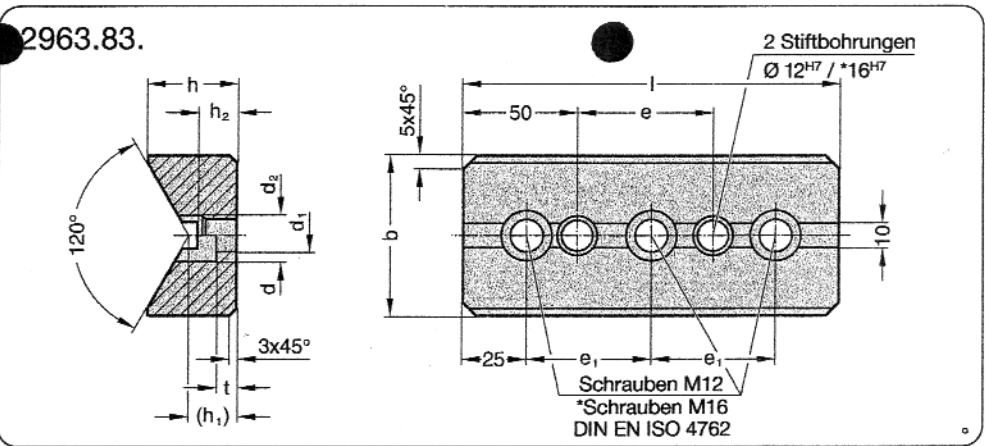
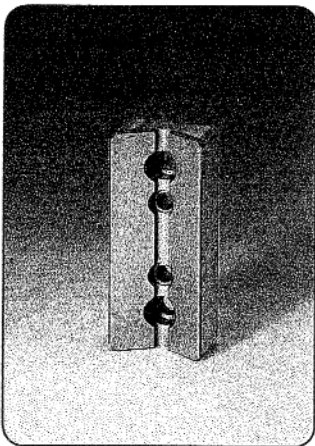

2963.83.

Bestell-Nr.	b	h	(h ₁)	h ₂	l	e	e ₁	d	d ₁	d ₂	t	Anzahl Schrauben
2963.83.065.040.0150	65	40	(23)	21	150	50	100	20	13,5	14	10	2
0200					200	100	150					2
0250					250	150	100					3
0300					300	200	125					3
2963.83.075.040.0150	75	40	(23)	21	150	50	100	20	13,5	14	10	2
0200					200	100	150					2
0250					250	150	100					3
0300					300	200	125					3
2963.83.125.060.0150*	125	60	(28)	27	150	50	100	26	17,5	18	15	2
0200*					200	100	150					2
0250*					250	150	100					3
0300*					300	200	125					3

Werkstoff:
Stahl, Gleitflächen oberflächengehärtet.

Hinweis:
Lieferung ohne Schrauben und Stifte.

Bestell-Beispiel:

Prismenführung = 2963.83.
b = 65 mm = 065.
h = 40 mm = 040.
l = 200 mm = 0200
Bestell-Nr = 2963.83.065.040.0200

**GELEIDINGSSTUK
3357**

Art. 2963.84/85

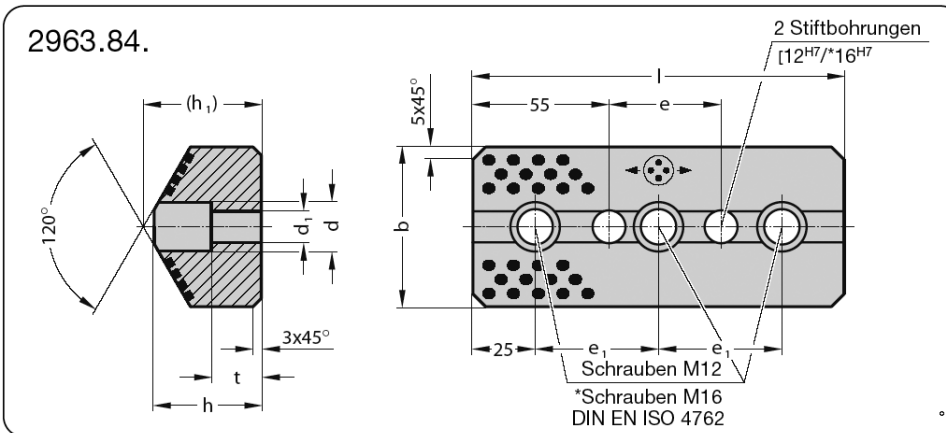

Bestell-Nr.	b	h	(h ₁)	h ₃	l	e	e ₁	d	d ₁	t	Nombre de vis
2963.84.065.044.0150	65	44	(47)	65	150	45	100	20	13,5	20	2
0200					200	95	150				2
0250					250	145	100				3
0300					300	195	125				3
2963.84.125.047.0150*	125	47	(52)	85	150	45	100	26	17,5	15	2
0200*					200	95	150				2
0250*					250	145	100				3
0300*					300	195	125				3
2963.84.125.052.0150*	125	52	(57)	85	150	45	100	26	17,5	15	2
0200*					200	95	150				2
0250*					250	145	100				3
0300*					300	195	125				3

Bestell-Beispiel: Gleitstück = 2963.84.
 b = 65 mm = 065.
 h = 44 mm = 044.
 l = 200 mm = 0200
 Bestell-Nr. = 2963.84.065.044.0200

Werkstoff:

Bronze mit Festschmierstoff, wartungsarm.

Hinweis:

Lieferung ohne Schrauben und Stifte.

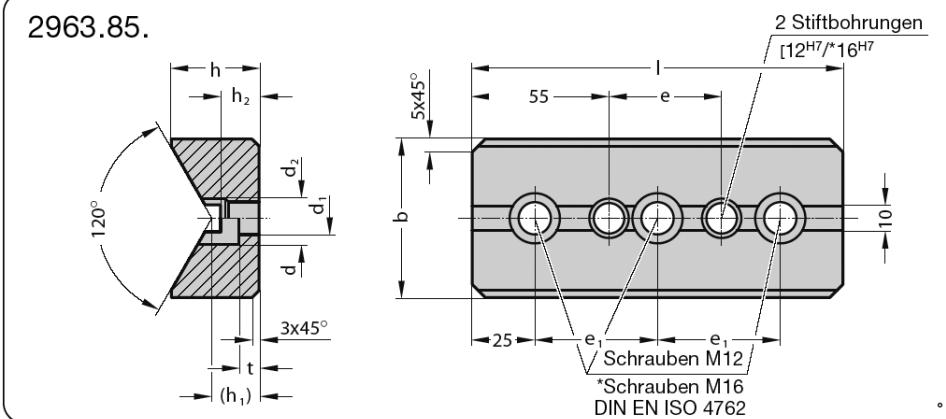

Bestell-Nr.	b	h	(h ₁)	h ₂	l	e	e ₁	d	d ₁	d ₂	Nombre tde vis	
2963.85.065.035.0150	65	35	(18)	17	65	150	45	100	20	13,5	14	8
0200					200	95	150					2
0250					250	145	100					3
0300					300	195	125					3
2963.85.125.060.0150*	125	60	(33)	32	85	150	45	100	26	17,5	18	15
0200*					200	95	150					2
0250*					250	145	100					3
0300*					300	195	125					3
2963.85.125.060.0150.1*	125	60	(28)	27	x	150	45	100	26	17,5	18	15
0200*					200	95	150					2
0250*					250	145	100					3
0300*					300	195	125					3

Bestell-Beispiel: Prismenführung = 2963.85.
 b = 65 mm = 065.
 h = 35 mm = 035.
 l = 200 mm = 0200
 Bestell-Nr. = 2963.85.065.035.0200

Werkstoff:

Stahl
Gleitflächen oberflächen-gehärtet.

Hinweis:

Lieferung ohne Schrauben und Stifte.

GELEIDINGSSTUK BRONS OF STAAL

Art. 2963.70/71

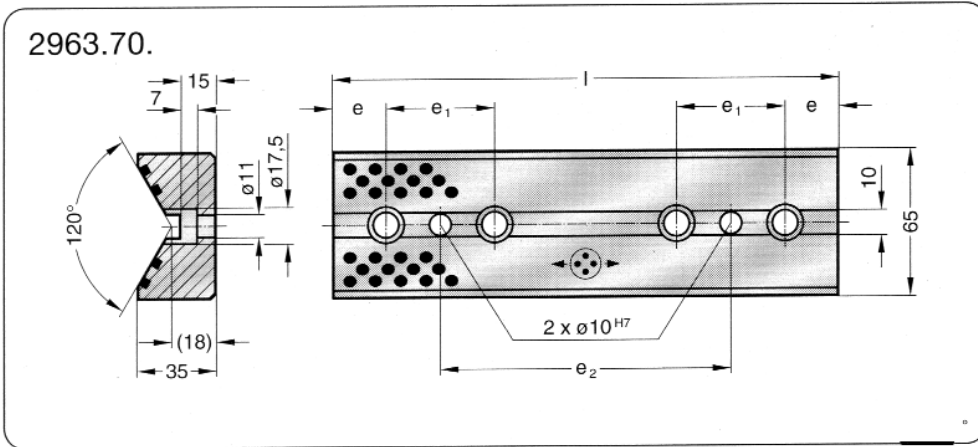
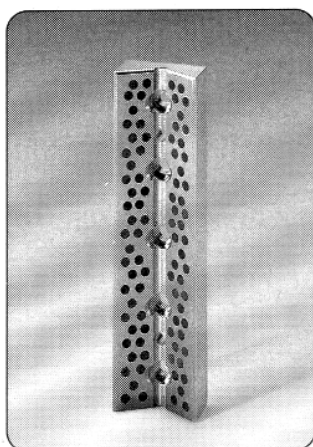

Werkstoff:
Bronze mit Festschmierstoff, wartungsarm.

Hinweis:
Lieferung ohne Schrauben und Stifte.

 Gleitrichtung Festschmierstoff-Einsätze (Ausschnitt)

2963.70.

Bestell.-Nr.	e	e ₁	e ₂	l	Anzahl Schrauben
2963.70.065.035.0100	20	60	20	100	2
0150	25	50	50	150	3
0200			100	200	4
0250			150	250	5
0300			200	300	6

Bestell-Beispiel:
Prismenführung = 2963.70.
Breite = 65 mm = 065.
Dicke = 35 mm = 035.
l = 250 mm = 0250
Bestell-Nummer = 2963.70.065.035.0250

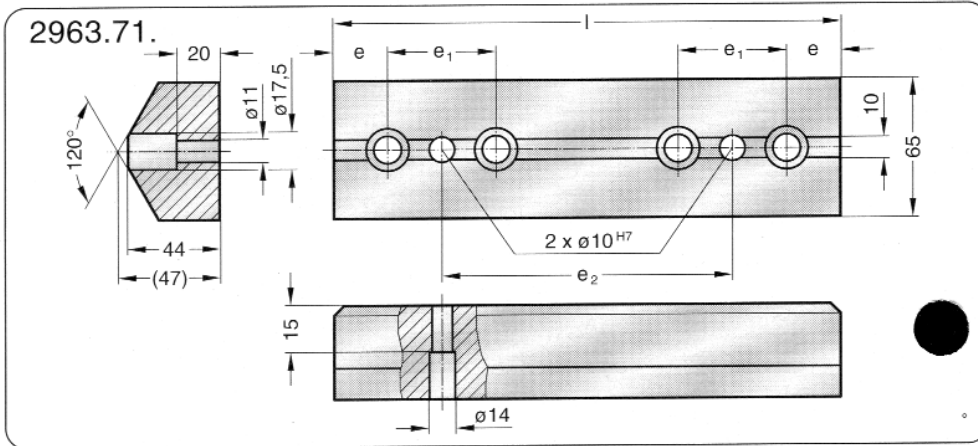
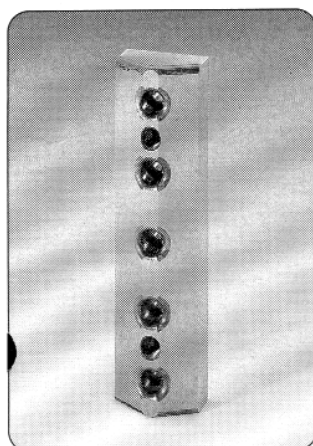

Werkstoff:
Stahl
Gleitflächen oberflächengehärtet.

Hinweis:
Lieferung ohne Schrauben und Stifte.

2963.71.

Bestell.-Nr.	e	e ₁	e ₂	l	Anzahl Schrauben
2963.71.065.044.0100	20	60	20	100	2
0150	25	50	50	150	3
0200			100	200	4
0250			150	250	5
0300			200	300	6

Bestell-Beispiel:
Gleitstück = 2963.71.
Breite = 65 mm = 065.
Dicke = 44 mm = 044.
l = 300 mm = 0300
Bestell-Nummer = 2963.71.065.044.0300

GELEIDINGSSTUK BRONS OF STAAL

Art. 2963.72/73

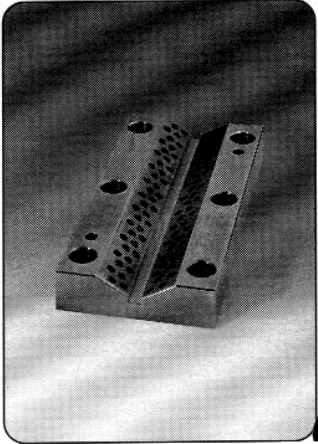
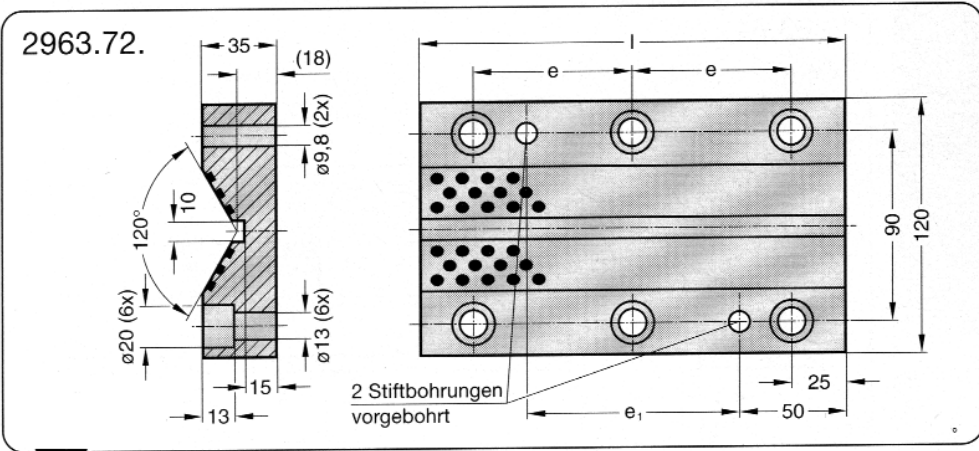

2963.72.

Bestell-Nr.	l	e	e ₁	Anzahl Schrauben
2963.72.120.035.0150	150	50	50	6
0200	200	75	100	6
0250	250	100	150	6
0300	300	125	200	6

Bestell-Beispiel:

Prismenführung = 2963.72.
 Breite = 120 mm = 120.
 Dicke = 35 mm = 035.
 l = 150 mm = 0150
 Bestell-Nummer = 2963.72.120.035.0150

Werkstoff:
 Bronze mit Festschmierstoff, wartungsarm.

Hinweis:
 Lieferung ohne Schrauben und Stifte.

 Gleitrichtung
 Festschmierstoff-Einsätze (Ausschnitt)

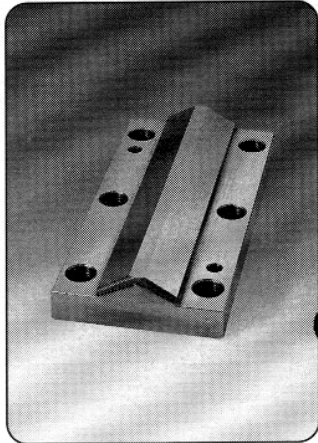
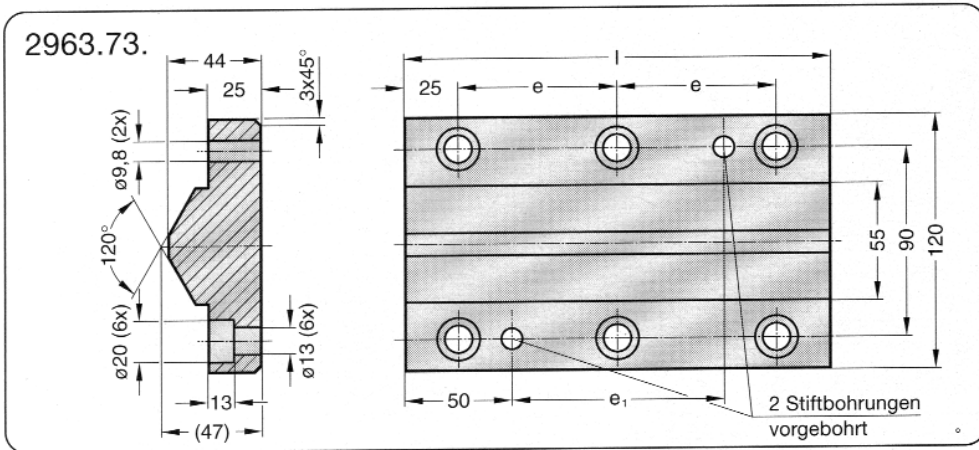

2963.73.

Bestell-Nr.	l	e	e ₁	Anzahl Schrauben
2963.73.120.044.0150	150	50	50	6
0200	200	75	100	6
0250	250	100	150	6
0300	300	125	200	6

Bestell-Beispiel:

Gleitstück = 2963.73.
 Breite = 120 mm = 120.
 Dicke = 44 mm = 044.
 l = 150 mm = 0150
 Bestell-Nummer = 2963.73.120.044.0150

Werkstoff:
 Stahl
 Gleitflächen oberflächengehärtet.

Hinweis:
 Lieferung ohne Schrauben und Stifte.

GELEIDINGSSTUK UIT STAAL

Art. 2963.81

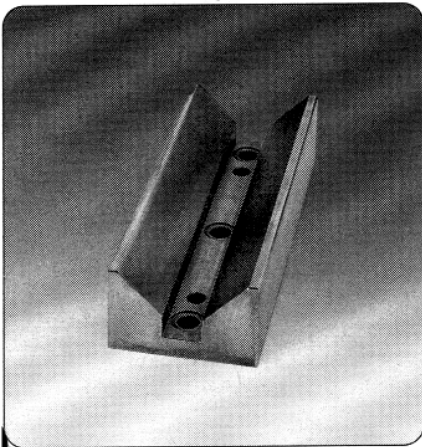

2963.81.

Form A

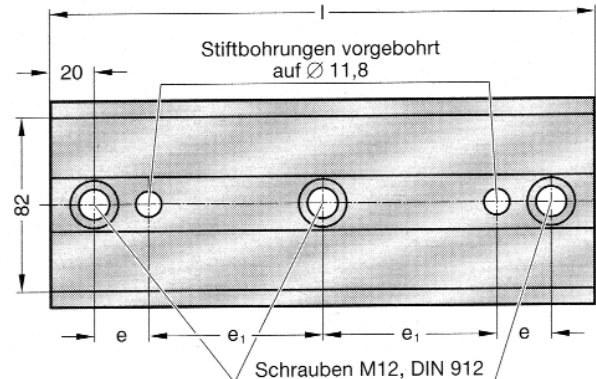
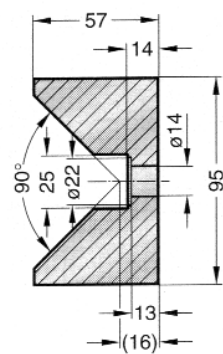

Form B

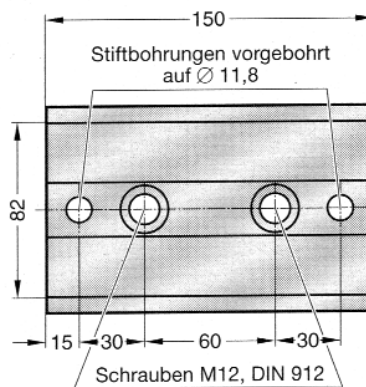

Form C

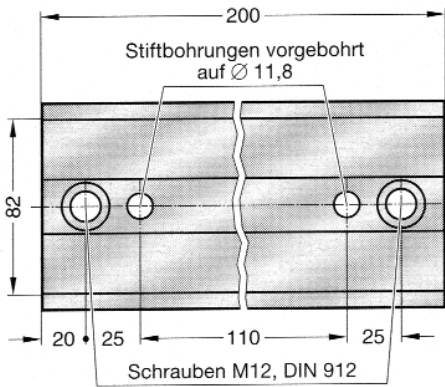

Werkstoff:
 Stahl
 Gleitflächen oberflächengehärtet.

Hinweis:
 Lieferung ohne Schrauben und Stifte.

2963.81.

Bestell-Nr.	Form	l	e	e ₁	Anzahl Schrauben
2963.81.095.057.0150	B	150	30	-	2
0200	C	200	25	-	2
0250	A	250	25	80	3
0300	A	300	30	100	3

Bestell-Beispiel:

Prismenführung = 2963.81.
 Breite = 95 mm = 095.
 Dicke = 57 mm = 057.
 l = 250 mm = 0250
 Bestell-Nummer = 2963.81.095.057.0250

GELEIDINGSSTUK

Art. 2963.80

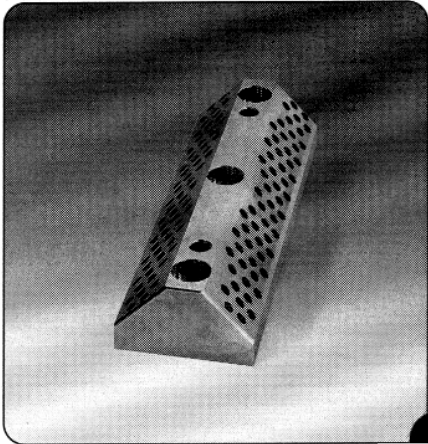
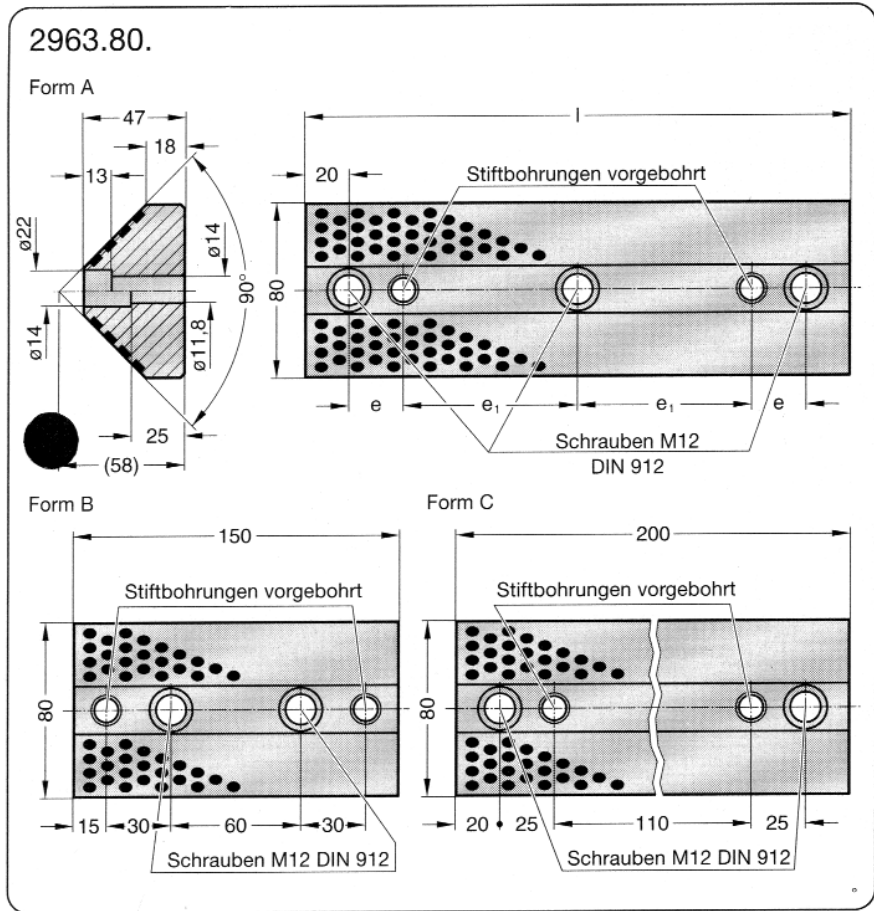

Werkstoff:
 Bronze mit Festschmierstoff,
 wartungsarm.

Hinweis:
 Lieferung ohne Schrauben und Stifte.

2963.80.

Bestell-Nr.	Form	l	e	e ₁	Anzahl Schrauben
2963.80.080.047.0150	B	150	30	-	2
0200	C	200	25	-	2
0250	A	250	25	80	3
0300	A	300	30	100	3

Bestell-Beispiel:

Gleitstück = 2963.80.
 Breite = 80 mm = 080.
 Dicke = 47 mm = 047.
 l = 250 mm = 0250
 Bestell-Nummer = 2963.80.080.047.0250

GELEIDINGSSTUK

Art. 2965.81

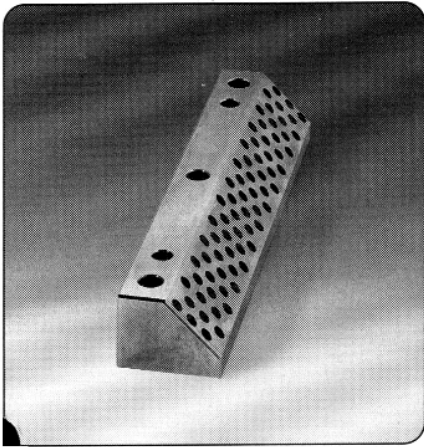

2965.81.

Form A

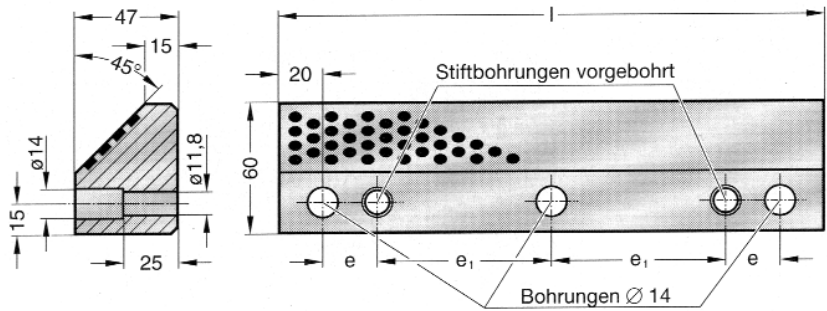

Form B

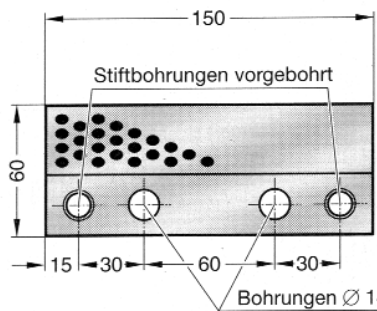

Form C

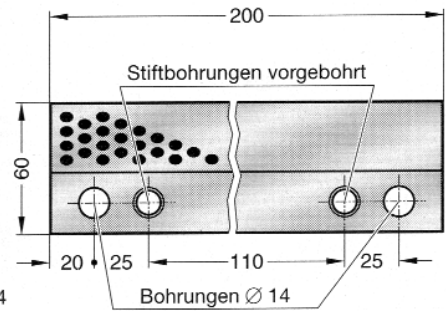

Werkstoff:

Bronze mit Festschmierstoff, wartungsarm.

Hinweis:

Einseiten-Prismen-Gleitstücke 2965.83. siehe gegenüberliegende Seite.
Lieferung ohne Schrauben und Stifte.

2965.81.

Bestell-Nr.	Form	l	e	e ₁	Anzahl Schrauben
2965.81.060.047.0150	B	150	30	-	2
0200	C	200	25	-	2
0250	A	250	25	80	3
0300	A	300	30	100	3

Bestell-Beispiel:

Einseiten-Prismenführung = 2965.81.
 Breite = 60 mm = 060.
 Dicke = 47 mm = 047.
 l = 250 mm = 0250
 Bestell-Nummer = 2965.81.060.047.0250

GELEIDINGSSTUK UIT STAAL

Art. 2965.83

2965.83.

Form A

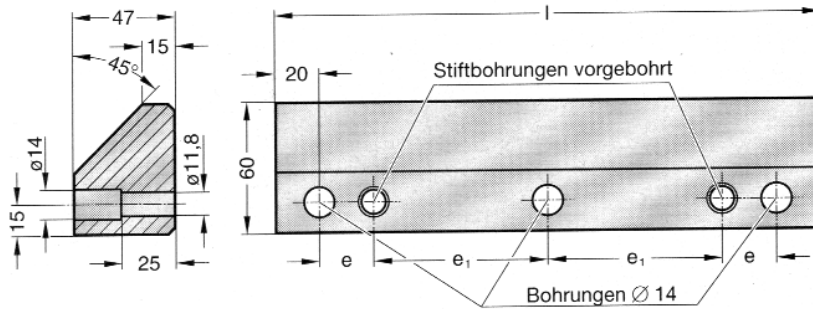

Form B

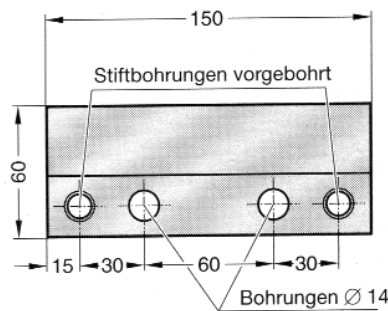

Form C

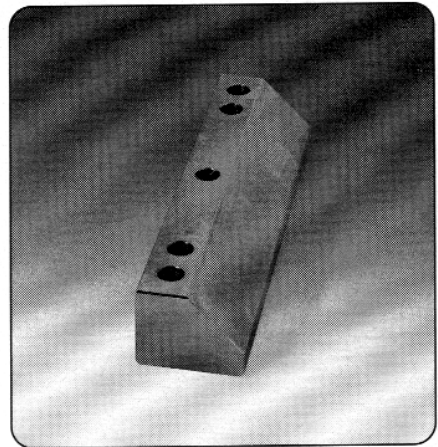
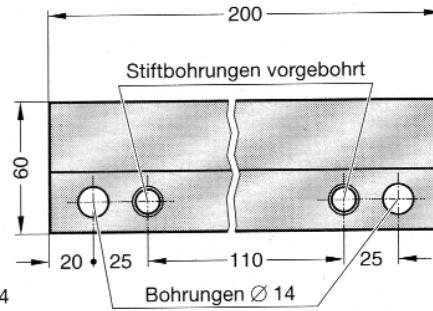

Werkstoff:

Stahl
Gleitflächen oberflächengehärtet.

Hinweis:

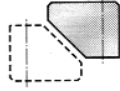
 Einseiten-Prismenführungen 2965.81. siehe gegenüberliegende Seite
Lieferung ohne Schrauben und Stifte.

2965.83.

Bestell-Nr.	Form	l	e	e ₁	Anzahl Schrauben
2965.83.060.047.0150	B	150	30	-	2
0200	C	200	25	-	2
0250	A	250	25	80	3
0300	A	300	30	100	3



Bestell-Beispiel:

Einseiten-Prismen-Gleitstücke = 2965.83.
 Breite = 60 mm = 060.
 Dicke = 47 mm = 047.
 l = 250 mm = 0250
 Bestell-Nummer = 2965.83.060.047.0250

GELEIDINGSSTUK

Art. 2965.80

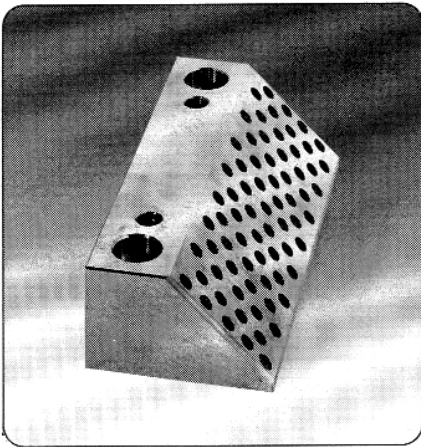

2965.80.

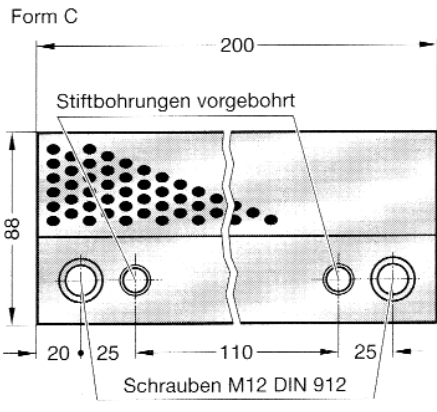
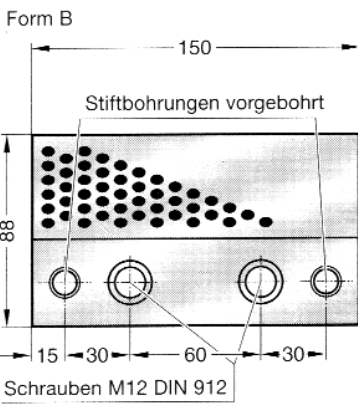
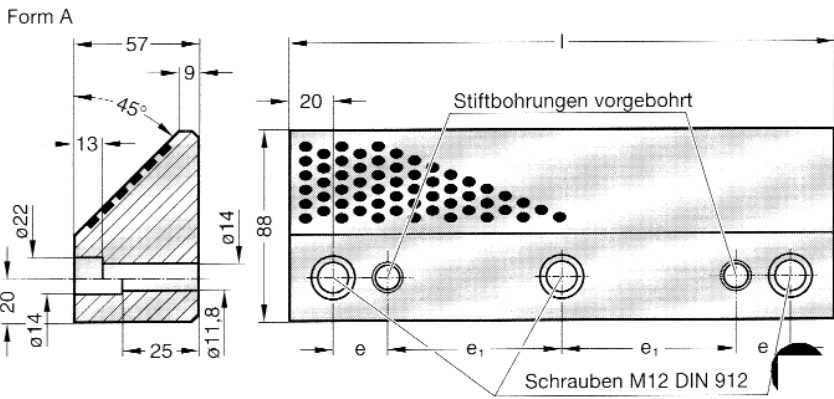

Werkstoff:
Bronze mit Festschmierstoff, wartungsarm.

Hinweis:
Einseiten-Prismen-Gleitstücke 2965.82. siehe gegenüberliegende Seite

Lieferung ohne Schrauben und Stifte.

2965.80.

Bestell-Nr.	Form	l	e	e ₁	Anzahl Schrauben
2965.80.088.057.0150	B	150	30	-	2
0200	C	200	25	-	2
0250	A	250	25	80	3
0300	A	300	30	100	3

Bestell-Beispiel:

Einseiten-Prismenführung = 2965.80.
 Breite = 88 mm = 088.
 Dicke = 57 mm = 057.
 l = 250 mm = 0250
 Bestell-Nummer = 2965.80.088.057.0250

GELEIDINGSSTUK UIT STAAL

Art. 2965.82

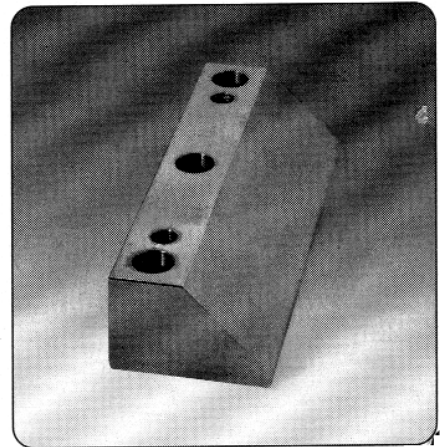
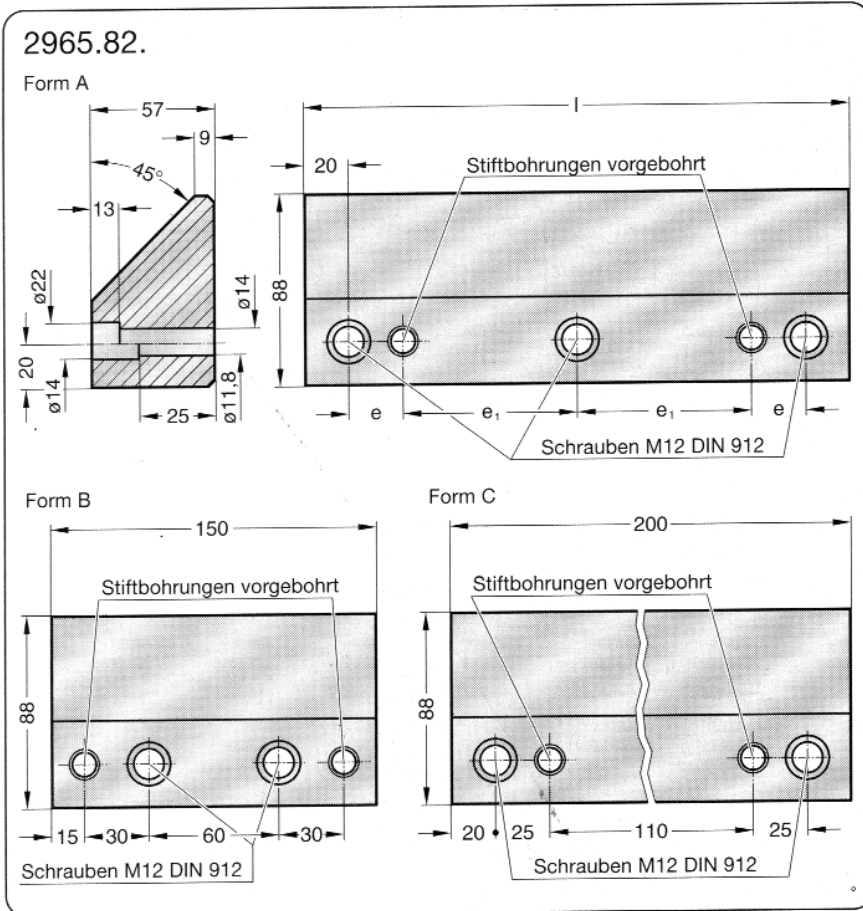

Werkstoff:

Stahl
Gleitflächen oberflächengehärtet.

Hinweis:

Einseiten-Prismenführungen 2965.80. siehe gegenüberliegende Seite

Lieferung ohne Schrauben und Stifte.

2965.82.

Bestell-Nr.	Form	l	e	e ₁	Anzahl Schrauben
2965.82.088.057.0150	B	150	30	-	2
0200	C	200	25	-	2
0250	A	250	25	80	3
0300	A	300	30	100	3

Bestell-Beispiel:

Einseiten-Prismen-Gleitstück = 2965.82.
 Breite = 88 mm = 088.
 Dicke = 57 mm = 057.
 l = 250 mm = 0250
 Bestell-Nummer = 2965.82.088.057.0250