

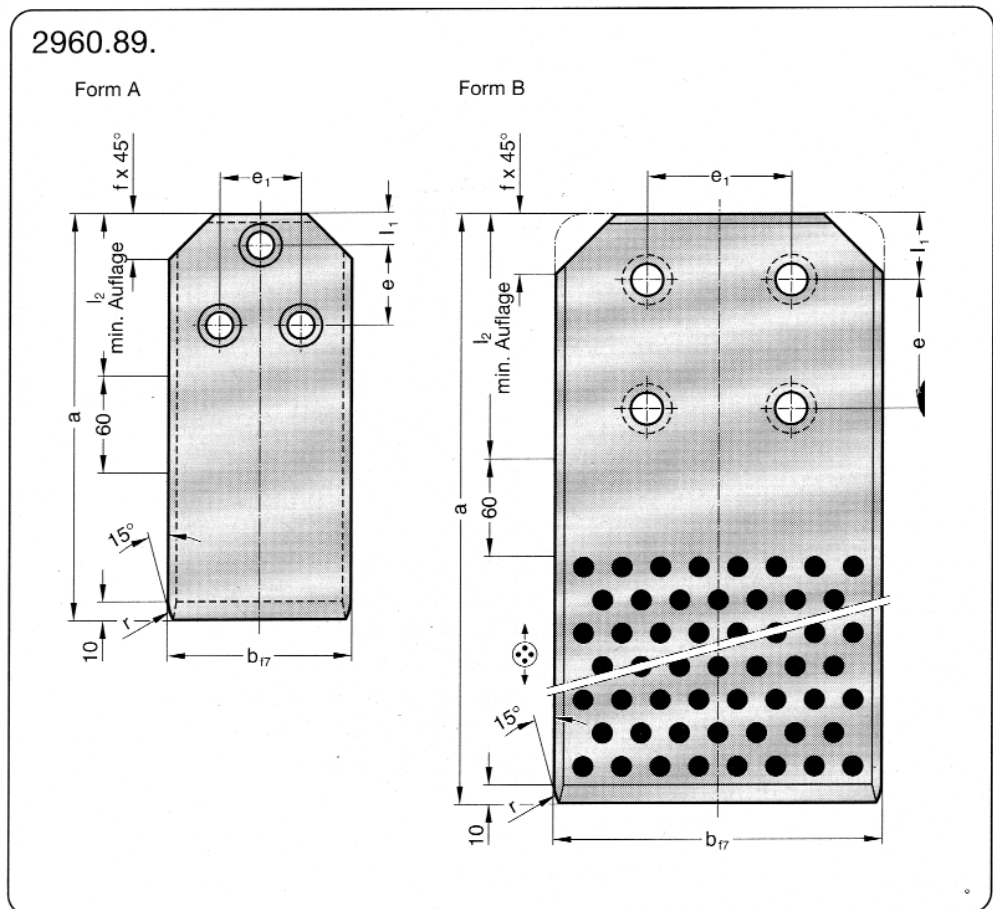

**WRIJVINGSPLAAT UIT STAAL  
VDI 3387**

Art. 2960.89

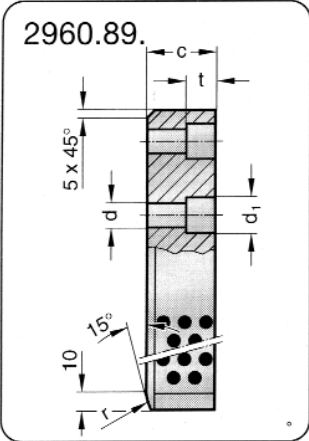
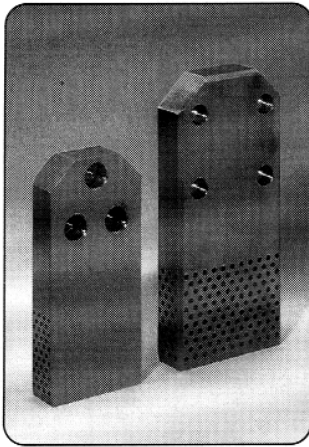

**Werkstoff:**

Bronze mit Festschmierstoff

**Hinweis:**

Lieferung ohne Schrauben.

**Befestigung:**

Zylinderschrauben  
DIN EN ISO 4762

- 2960.89.063 M12×40
  - 2960.89.071 M12×40
  - 2960.89.090 M16×50
  - 2960.89.112 M16×50
  - 2960.89.140 M20×50
  - 2960.89.190 M20×70
  - 2960.89.240 M24×80
- verwenden.



Gleitrichtung  
Festschmierstoff-Einsätze  
(Ausschnitt)

**2960.89.**

Bestell-Nr.	Form	b	a	l <sub>1</sub>	l <sub>2</sub>	e	e <sub>1</sub>	d	d <sub>1</sub>	f	c	t	r	Anzahl Bohrungen
2960.89.063.180	A	63	180	20	90	50	36	14	20	18	36	16	16	3
200			200											
224			224											
2960.89.071.180	A	71	180											
200			200											
224			224											
2960.89.090.200	A	90	200	20	100	50	50	18	26	28	45	21	25	3
224			224											
250			250											
2960.89.112.200	A	112	200											
224			224											
250			250											
2960.89.140.315	B	140	315	40	150	80	90	22	33	36	45	25,5	31,5	4
2960.89.190.400			190	400							56			
2960.89.240.500		240	500		250	160	160	26	40				30,5	
630			630											

**Bestell-Beispiel:**

Führungslasche = 2960.89.  
 b = 140 mm = 140.  
 a = 315 mm = 315  
 Bestell-Nr. = 2960.89.140.315