

**SNELWISSELPONSNIPPEL
BESTELVOORBEELD**

Hinweis: Normabmessung siehe Tabelle
Sonderanfertigung auf Anfrage

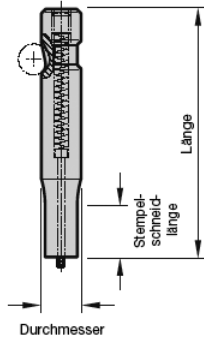

Schneidstempel:
22 ohne Abdruckstift
27 mit Abdruckstift

2 2 4 2 . 2 F 1 . 0 6 5 0 . 0 4 5 0 A

Stempelschneid- länge: l_1	Bestellziffer
13	= 1
19	= 2
25	= 3
30	= 4
Sonder	= X

Form Langloch:
Länge P = 6,5 mm

Form:
Langloch
Breite
W = 4,5 mm

Ausführung:	Bestellziffer
○ Rohling	= 0
⊙ Rund	= 1
□ Quadrat	= 2
▭ Rechteck	= 3
⊖ Langloch	= 4
⊖ Rechteck mit Radius	= 5
▽ Suchstift Kegelspitze	= 6
▽ Suchstift Parabolspitze	= 7
Sonderformen	= 9

Durchmesser: d_2	Bestellziffer
6 (nur leichte)	= 1
10	= 2
13	= 3
16	= 4
20	= 5
25	= 6
32	= 7
38 (nur leichte Ausführung)	= 8
40 (nur schwere Ausführung)	= 9

Länge: l	Bestell- buchstabe
50	= A
56	= B
63	= C
71	= D
80	= E
90	= F
100	= G
110	= H
125	= J
140	= K
150	= L
175	= M
200	= N
Sonder	= X

Winkel:	Bestell- buchstabe
0°	= A
90°	= B
180°	= C
270°	= D
Sonder	= X

Typ:	Bestellziffer
leicht	= 2
schwer	= 3
Schneide, größer, leicht	= 4
Schneide, größer, schwer	= 5

Bestell-Beispiel:

22 4 2 . 2 F 1 . 0 6 5 0 . 0 4 5 0 A

- Winkel = 0° (A)
- Form: Langloch Breite W = 4,5 mm (0450)
- Form: Langloch Länge P = 6,5 mm (0650)
- Schneidstempellänge: l_1 = 13 mm (1)
- Länge: l = 90 mm (F)
- Durchmesser: d_2 = 10 mm (2)
- Typ = leicht (2)
- Ausführung: Langloch (4)
- Schneidstempel: ohne Abdruckstift (22)

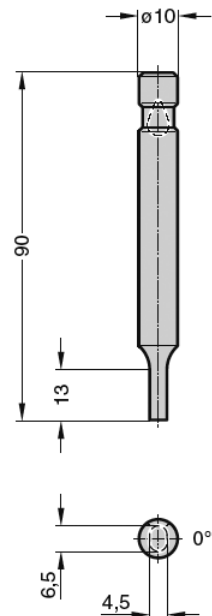

**SNELWISSELPONSNIPPEL
LICHT BELASTBAAR**

Art. 2202 / 2212

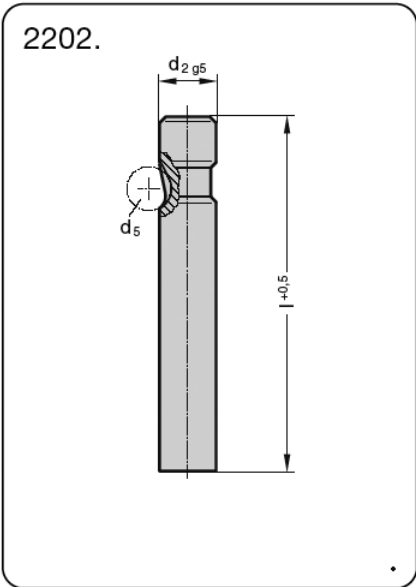

Werkstoff:
HSS
gehärtet: 62 ± 2 HRC

Ausführung:
Schaft feinstgeschliffen.

Andere Längen auf Anfrage.

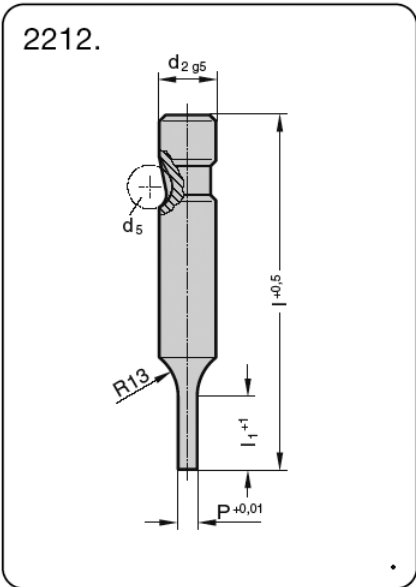

Werkstoff:
HSS
gehärtet: 62 ± 2 HRC

Ausführung:
Schaft und Schneiddurchmesser feinstgeschliffen.

Andere Längen auf Anfrage.

2202.

d ₂	d ₅	63	71	80	90	100	110	125	140	150	175	200
6	6	●	●	●	●	●						
10	8	●	●	●	●	●	●	●				
13	8	●	●	●	●	●	●	●	●	●	●	●
16	8	●	●	●	●	●	●	●	●	●	●	●
20	8	●	●	●	●	●	●	●	●	●	●	●
25	8	●	●	●	●	●	●	●	●	●	●	●
32	8		●	●	●	●	●	●	●	●	●	●
38	8			●	●	●	●	●	●	●	●	●

Bestell-Beispiel:
siehe Ausklappseite E 29.

2212.

d ₂	d ₅	P		l ₁	63	71	80	90	100
6	6	1,6–	5,9	13*	●	●	●	●	●
10	8	1,6–	9,9	13* 19*	●	●	●	●	●
13	8	5,0–	12,9	13 19	●	●	●	●	●
16	8	8,0–	15,9	13 19 25	●	●	●	●	●
20	8	12,0–	19,9	13 19 25	●	●	●	●	●
25	8	16,0–	24,9	13 19 25	●	●	●	●	●
32	8	24,0–	31,9	13 19 25		●	●	●	●
38	8	30,0–	37,9	19 25 30			●	●	●

* l₁ = 10 wenn P < 2,20

Bestell-Beispiel:
siehe Ausklappseite E 29.

**SNELWISSELPONSNIPPEL
LICHT BELASTBAAR**

Art. 2222 /32/42/52

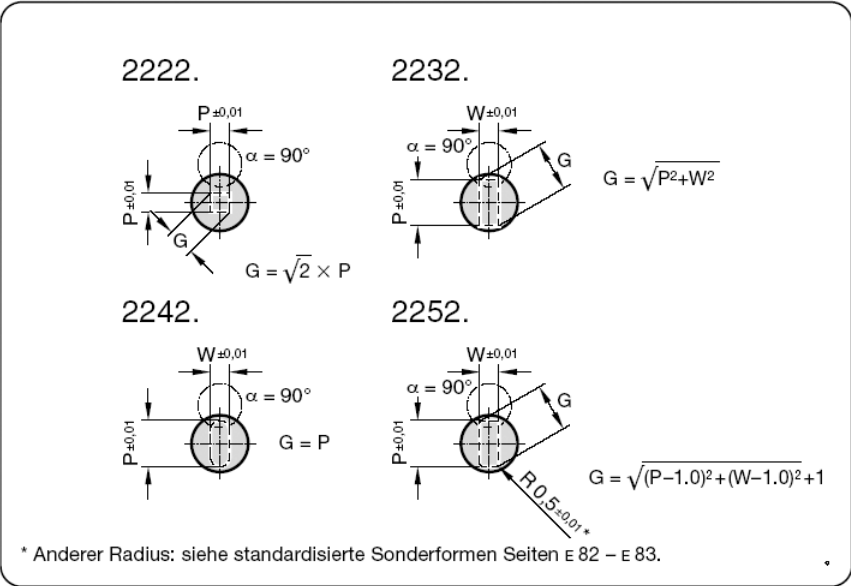

Werkstoff:
HSS
gehärtet: 62 ± 2 HRC

Ausführung:
Schaft und Schneidform feinstgeschliffen.

Andere Längen auf Anfrage.

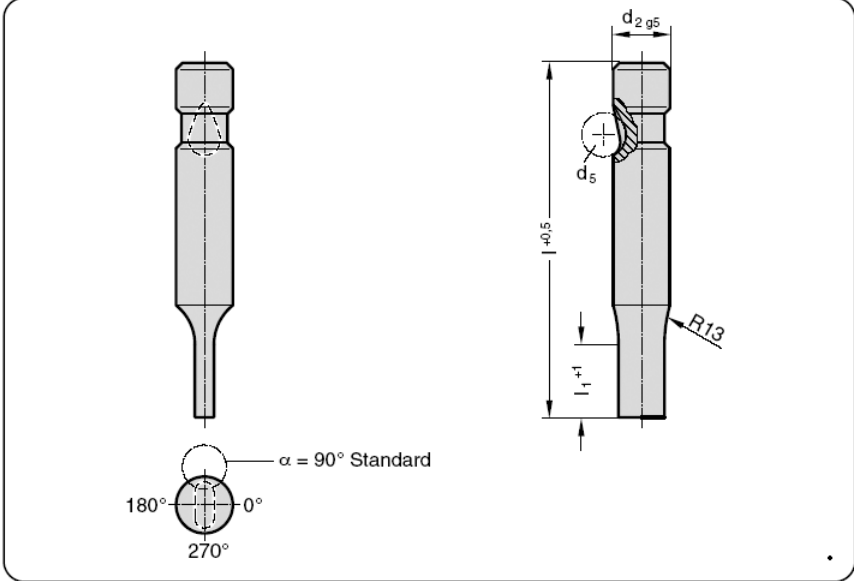

d ₂	d ₅	W _{min.}	G _{max.}	l ₁	l				
					63	71	80	90	100
6	6	1,6	5,9	13*	●	●	●	●	●
10	8	1,6	9,9	13* 19*	●	●	●	●	●
13	8	4,5	12,9	13 19	●	●	●	●	●
16	8	6,0	15,9	13 19 25	●	●	●	●	●
20	8	8,0	19,9	13 19 25	●	●	●	●	●
25	8	10,0	24,9	13 19 25	●	●	●	●	●
32	8	12,5	31,9	13 19 25		●	●	●	●
38	8	14,0	37,9	19 25 30			●	●	●

* l₁ = 10 wenn P oder W < 2,20

Bestell-Beispiel:
siehe Ausklappseite E 29.

**SNELWISSELPONSNIPPEL MET UITWERPER
LICHT BELASTBAAR**

Art. 2702 / 2712

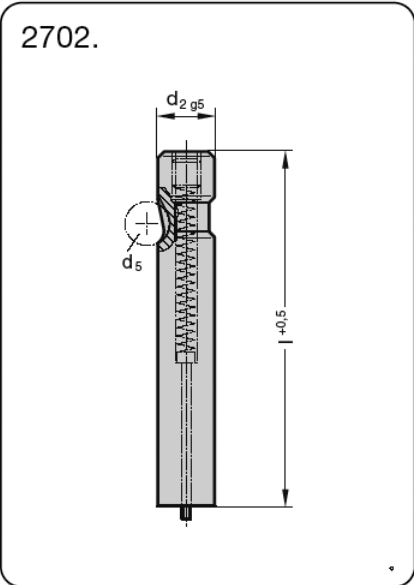

Werkstoff:
HSS
gehärtet: 62 ± 2 HRC

Ausführung:
Schaft feinstgeschliffen.

Andere Längen auf Anfrage.

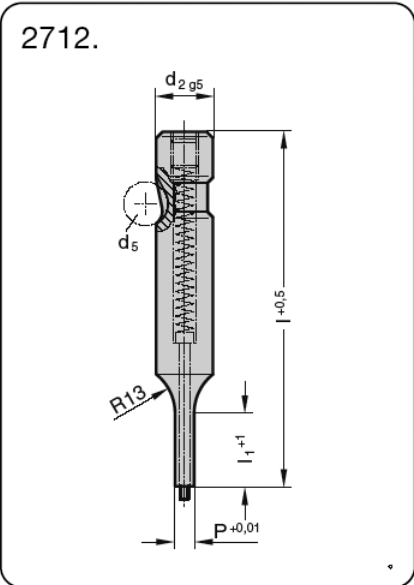

Werkstoff:
HSS
gehärtet: 62 ± 2 HRC

Ausführung:
Schaft und Schneiddurchmesser feinstgeschliffen.

Andere Längen auf Anfrage.

2702.

d ₂	d ₅	63	71	80	90	100
6	6	●	●	●	●	●
10	8	●	●	●	●	●
13	8	●	●	●	●	●
16	8	●	●	●	●	●
20	8	●	●	●	●	●
25	8	●	●	●	●	●
32	8		●	●	●	●
38	8			●	●	●

Bestell-Beispiel:
siehe Ausklappseite E 29.

2712.

d ₂	d ₅	P	l ₁	63	71	80	90	100
6	6	1,6– 5,9	13*	●	●	●	●	●
10	8	1,6– 9,9	13* 19*	●	●	●	●	●
13	8	5,0–12,9	13 19	●	●	●	●	●
16	8	8,0–15,9	13 19 25	●	●	●	●	●
20	8	12,0–19,9	13 19 25	●	●	●	●	●
25	8	16,0–24,9	13 19 25	●	●	●	●	●
32	8	24,0–31,9	13 19 25		●	●	●	●
38	8	30,0–37,9	19 25 30			●	●	●

Bestell-Beispiel:
siehe Ausklappseite E 29.

**SNELWISSELPONSNIPPEL MET UITWERPER
LICHT BELASTBAAR**

Art. 2722 /32/42/52

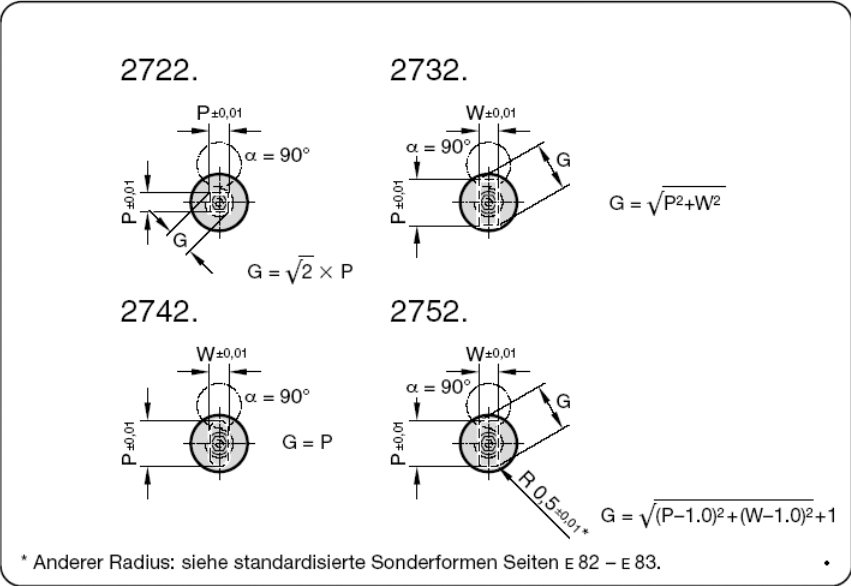

Werkstoff:
HSS
gehärtet: 62 ± 2 HRC

Ausführung:
Schaft und Schneidform feinstgeschliffen.

Andere Längen auf Anfrage.

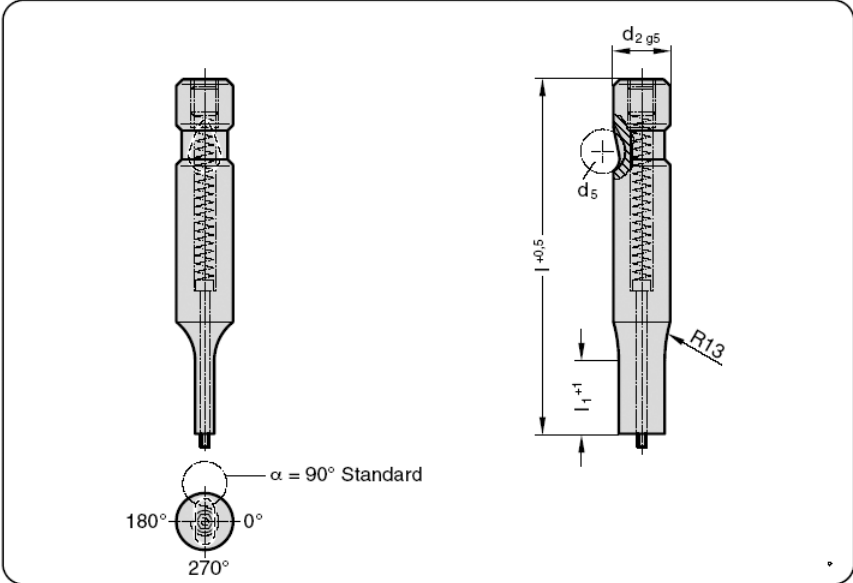

d ₂	d ₅	W _{min.}	G _{max.}	M	I ₁	I				
						63	71	80	90	100
6	6	1,6	5,9	3	13*	●	●	●	●	●
10	8	1,6	9,9	5	13* 19*	●	●	●	●	●
13	8	4,5	12,9	5	13 19	●	●	●	●	●
16	8	6,0	15,9	6	13 19 25	●	●	●	●	●
20	8	8,0	19,9	6	13 19 25	●	●	●	●	●
25	8	10,0	24,9	6	13 19 25	●	●	●	●	●
32	8	12,5	31,9	8	13 19 25		●	●	●	●
38	8	14,0	37,9	8	19 25 30			●	●	●

* I₁ = 10 wenn P oder W < 2,20

Bestell-Beispiel:
siehe Ausklappseite E 29.

**SNELWISSELPONSNIPPEL
LICHT BELASTBAAR
SNIJLICHAAM > SCHACHT**

Art. 2204 / 2214

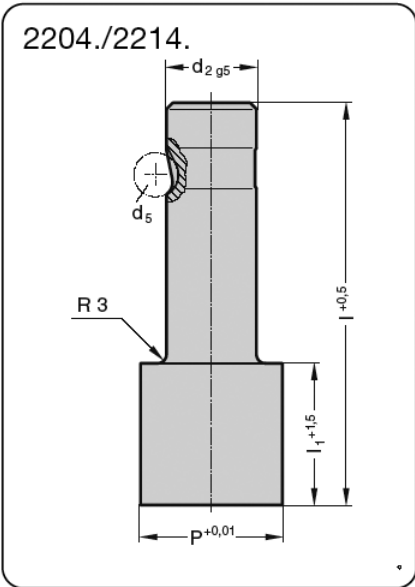

Werkstoff:
HSS
gehärtet: 62 ±2 HRC

Ausführung:
Schaft und Schneiddurchmesser
feinstgeschliffen.

Andere Längen auf Anfrage.

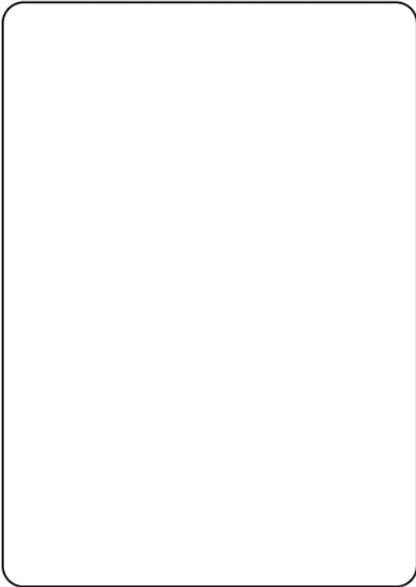
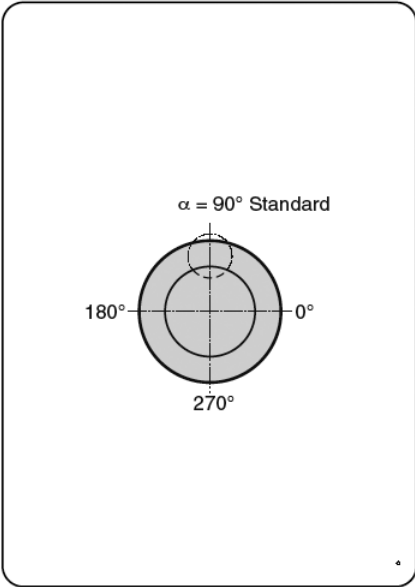

2204.

d ₂	d ₅	P	l ₁		l		
					80	90	100
13	8	32,0	19	30	●	●	●
16	8	38,0	19	30	●	●	●
20	8	40,0	19	30	●	●	●
25	8	44,0	19	30	●	●	●
32	8	50,0	19	30	●	●	●

Bestell-Beispiel:
siehe Ausklappseite E 29.

2214.

d ₂	d ₅	P	l ₁		l		
					80	90	100
13	8	13,1 – 32,0	19	30	●	●	●
16	8	16,1 – 38,0	19	30	●	●	●
20	8	20,1 – 40,0	19	30	●	●	●
25	8	25,1 – 44,0	19	30	●	●	●
32	8	32,1 – 50,0	19	30	●	●	●

Bestell-Beispiel:
siehe Ausklappseite E 29.

**SNELWISSELPONSNIPPEL
LICHT BELASTBAAR
SNIJLICHAAM > SCHACHT**

Art. 2224 /34/44/54

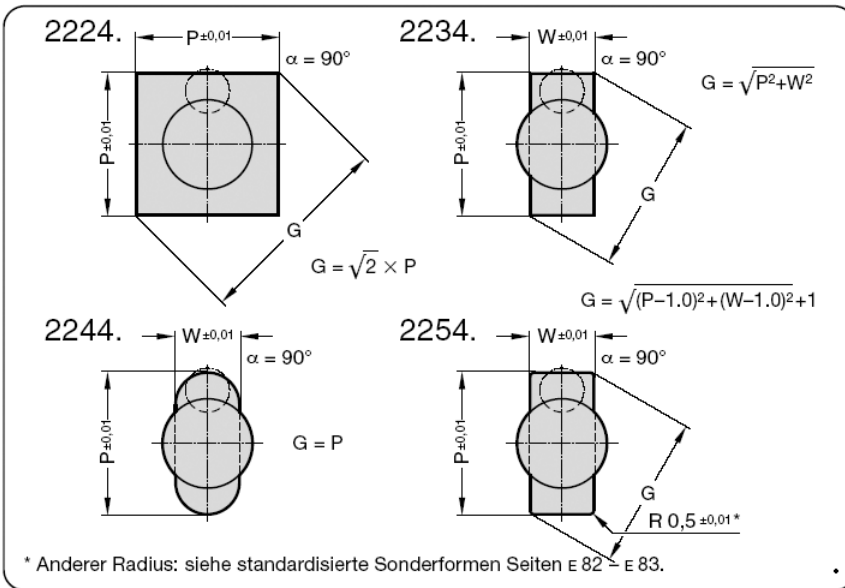

Werkstoff:

HSS
gehärtet: 62 ± 2 HRC

Ausführung:

Schaft und Schneidform feinstgeschliffen.

Andere Längen auf Anfrage.

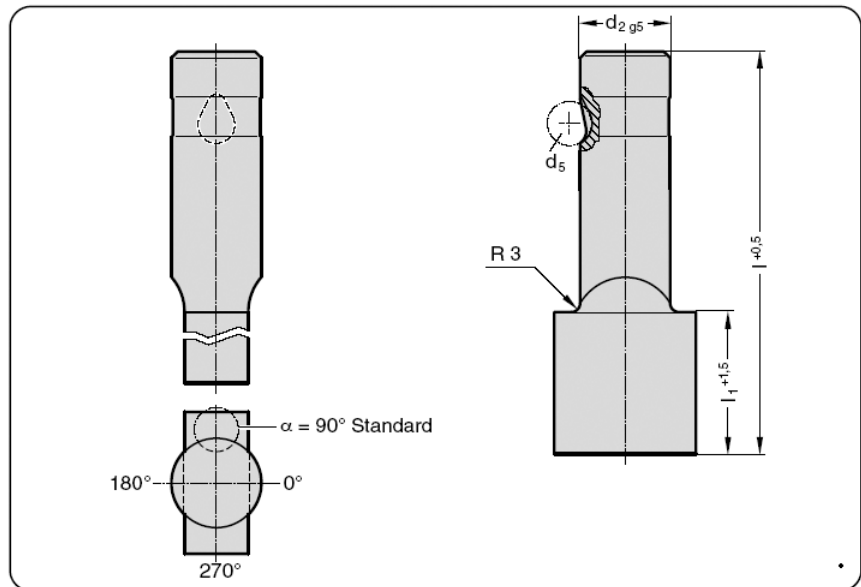

d_2	d_5	$W_{\min.}$	$G_{\max.}$	l_1	l		
					80	90	100
13	8	5,0	32,0	19 30	●	●	●
16	8	6,5	38,0	19 30	●	●	●
20	8	8,0	40,0	19 30	●	●	●
25	8	10,0	44,0	19 30	●	●	●
32	8	11,5	50,0	19 30	●	●	●

Bestell-Beispiel:

siehe Ausklappseite E 29.

**SNELWISSELPONSNIPPEL
LICHT BELASTBAAR
SNIJLICHAAM > SCHACHT**

Art. 2704 / 2714

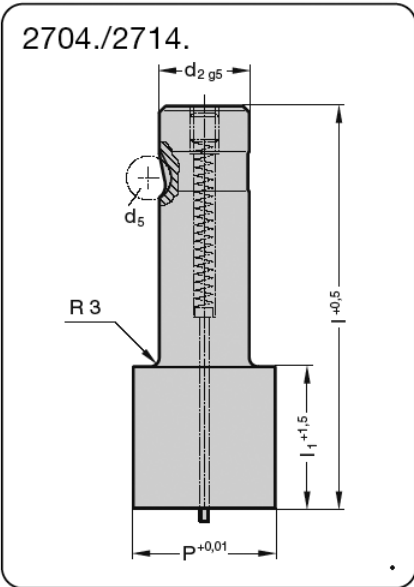

Werkstoff:
HSS
gehärtet: 62 ± 2 HRC

Ausführung:
Schaft und Schneiddurchmesser
feinstgeschliffen.

Andere Längen auf Anfrage.

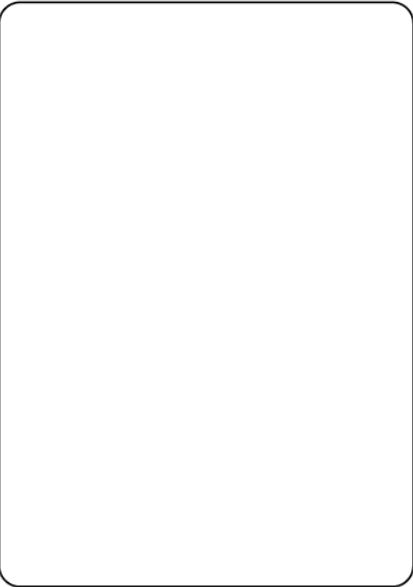
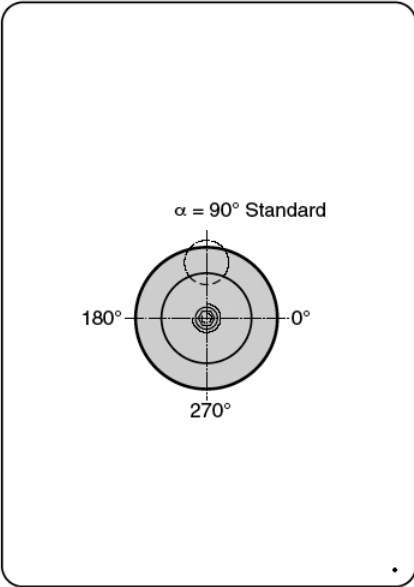
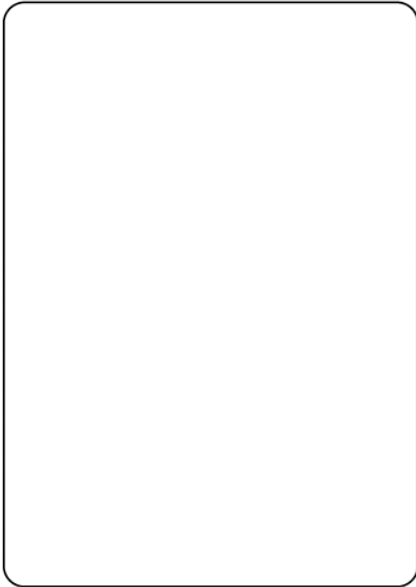

2704.

d ₂	d ₅	P	l ₁		l		
			80	90	100		
13	8	32,0	19	30	●	●	●
16	8	38,0	19	30	●	●	●
20	8	40,0	19	30	●	●	●
25	8	44,0	19	30	●	●	●
32	8	50,0	19	30	●	●	●

Bestell-Beispiel:
siehe Ausklappseite E 29.

2714.

d ₂	d ₅	P	l ₁		l		
			80	90	100		
13	8	13,1 – 32,0	19	30	●	●	●
16	8	16,1 – 38,0	19	30	●	●	●
20	8	20,1 – 38,0	19	30	●	●	●
25	8	25,1 – 45,0	19	30	●	●	●
32	8	32,1 – 50,0	19	30	●	●	●

Bestell-Beispiel:
siehe Ausklappseite E 29.

**SNELWISSELPONSNIPPEL MET UITWERPER
LICHT BELASTBAAR
SNIJLICHAAM > SCHACHT**

Art. 2724 /34/44/54

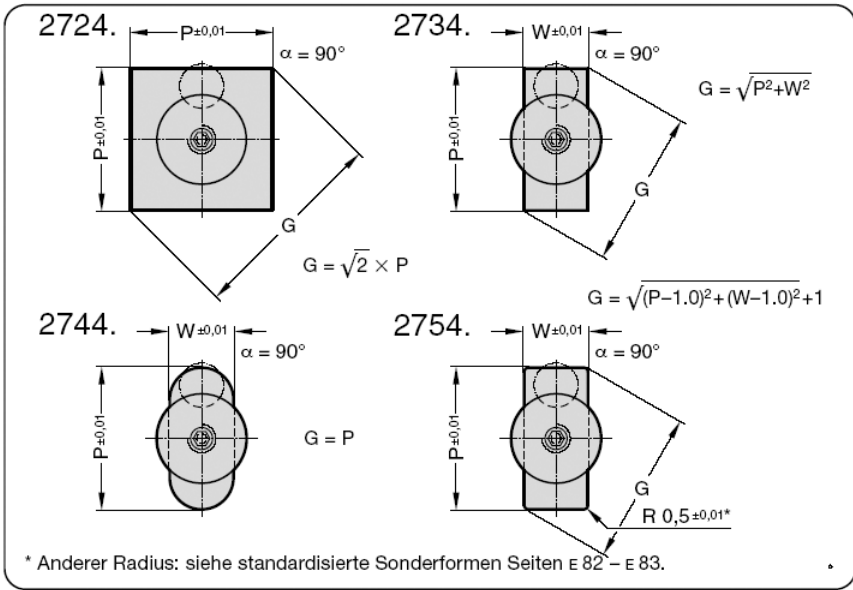

Werkstoff:
HSS
gehärtet: 62 ± 2 HRC

Ausführung:
Schaft und Schneidform feinstgeschliffen.

Andere Längen auf Anfrage.

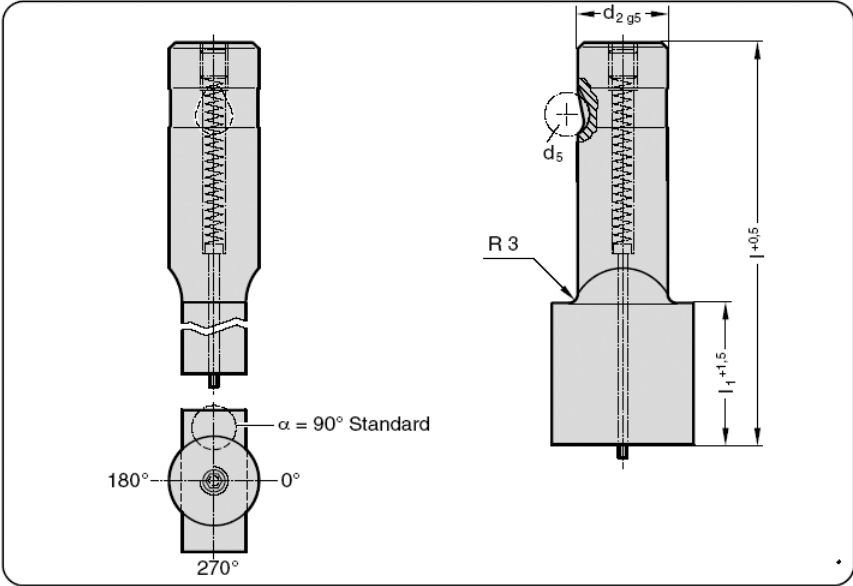

d_2	d_5	$W_{min.}$	$G_{max.}$	l_1	l		
					80	90	100
13	8	5,0	32,0	19 30	●	●	●
16	8	6,5	38,0	19 30	●	●	●
20	8	8,0	40,0	19 30	●	●	●
25	8	10,0	44,0	19 30	●	●	●
32	8	11,5	50,0	19 30	●	●	●

Bestell-Beispiel:
siehe Ausklappseite E 29.

**SNELWISSELPONSNIPPEL
ZWAAR BELASTBAAR**

Art. 2203 / 2213

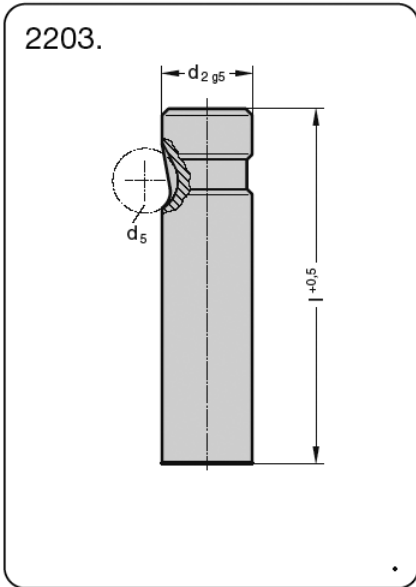

Werkstoff:
HSS
gehärtet: 62 ± 2 HRC

Ausführung:
Schaft feinstgeschliffen.

Andere Längen auf Anfrage.

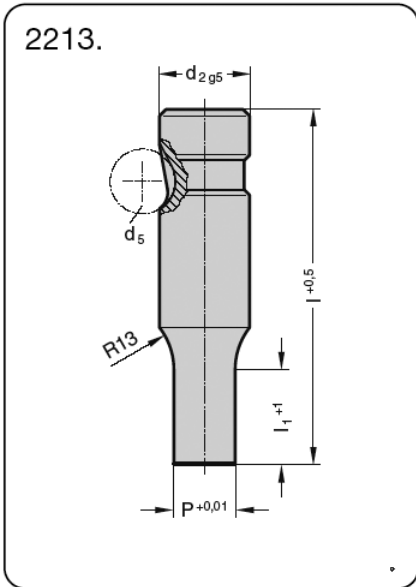

Werkstoff:
HSS
gehärtet: 62 ± 2 HRC

Ausführung:
Schaft und Schneiddurchmesser feinstgeschliffen.

Andere Längen auf Anfrage.

2203.

d ₂	d ₅	l										
		63	71	80	90	100	110	125	140	150	175	200
10	10	●	●	●	●	●	●	●				
13	12	●	●	●	●	●	●	●	●	●	●	
16	12	●	●	●	●	●	●	●	●	●	●	
20	12	●	●	●	●	●	●	●	●	●	●	
25	12		●	●	●	●	●	●	●	●	●	●
32	12		●	●	●	●	●	●	●	●	●	●
40	12			●	●	●	●	●	●	●	●	●

Bestell-Beispiel:
siehe Ausklappseite E 29.

2213.

d ₂	d ₅	P		l ₁		l						
						63	71	80	90	100	110	125
10	10	1,6–	9,9	13*	19*	●	●	●	●	●	●	●
13	12	5,0–	12,9	13	19	●	●	●	●	●	●	●
16	12	8,0–	15,9	13	19	25	●	●	●	●	●	●
20	12	12,0–	19,9	13	19	25	●	●	●	●	●	●
25	12	16,0–	24,9	13	19	25		●	●	●	●	●
32	12	24,0–	31,9	13	19	25		●	●	●	●	●
40	12	30,0–	39,9	19	25	30			●	●	●	●

* l₁ = 10 wenn P < 2,20

Bestell-Beispiel:
siehe Ausklappseite E 29.

**SNELWISSELPONSNIPPEL
ZWAAR BELASTBAAR**

Art. 2223 /33/43/53

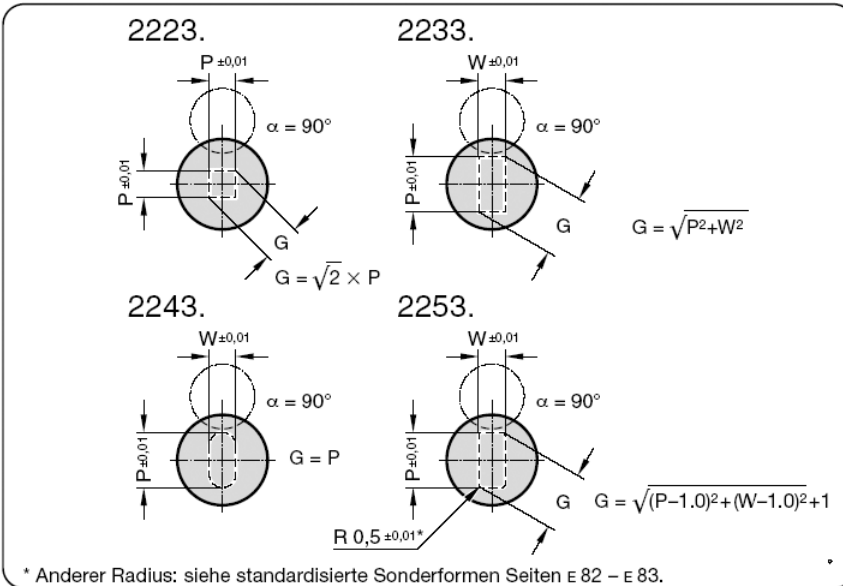

* Anderer Radius: siehe standardisierte Sonderformen Seiten E 82 – E 83.

Werkstoff:

HSS
gehärtet: 62 ± 2 HRC

Ausführung:

Schaft und Schneidform feinstgeschliffen.

Andere Längen auf Anfrage.

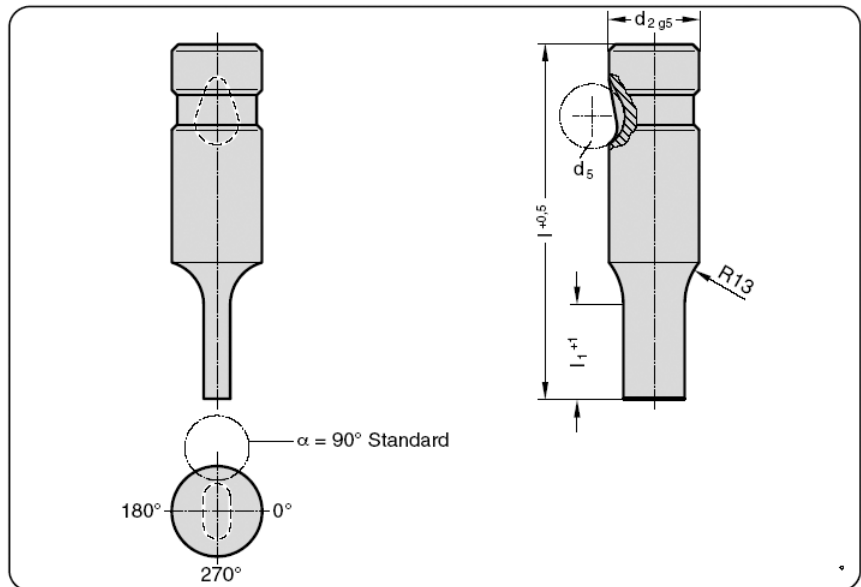

d ₂	d ₅	W _{min.}	G _{max.}	l ₁		l								
				63	71	80	90	100	110	125				
10	10	1,6	9,9	13*	19*	●	●	●	●	●	●	●	●	●
13	12	4,5	12,9	13	19	●	●	●	●	●	●	●	●	●
16	12	6,0	15,9	13	19	25	●	●	●	●	●	●	●	●
20	12	8,0	19,9	13	19	25	●	●	●	●	●	●	●	●
25	12	10,0	24,9	13	19	25	●	●	●	●	●	●	●	●
32	12	12,5	31,9	13	19	25	●	●	●	●	●	●	●	●
40	12	14,0	39,9	19	25	30	●	●	●	●	●	●	●	●

*l₁ = 10 wenn P oder W < 2,20

Bestell-Beispiel:

siehe Ausklappseite E 29.

**SNELWISSELPONSNIPPEL
ZWAAR BELASTBAAR**

Art. 2703 /2713

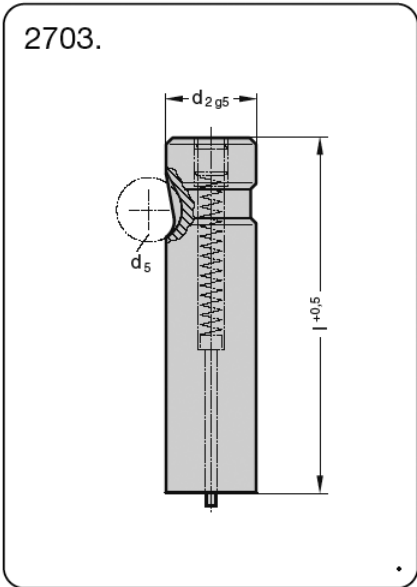

Werkstoff:
HSS
gehärtet: 62 ± 2 HRC

Ausführung:
Schaft feinstgeschliffen.

Andere Längen auf Anfrage.

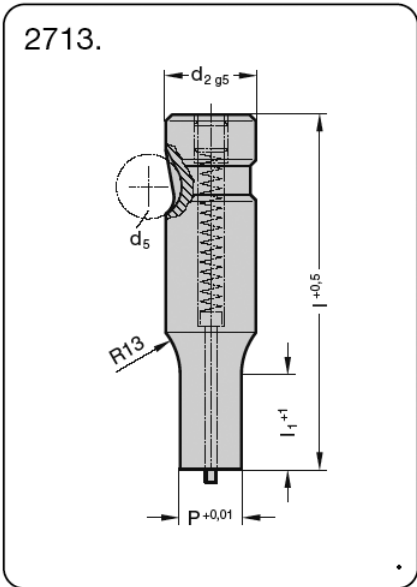

Werkstoff:
HSS
gehärtet: 62 ± 2 HRC

Ausführung:
Schaft und Schneiddurchmesser feinstgeschliffen.

Andere Längen auf Anfrage.

2703.

d ₂	d ₅	63	71	80	90	100	110	125
10	10	●	●	●	●	●		
13	12	●	●	●	●	●	●	●
16	12	●	●	●	●	●	●	●
20	12	●	●	●	●	●	●	●
25	12		●	●	●	●	●	●
32	12		●	●	●	●	●	●
40	12			●	●	●	●	●

Bestell-Beispiel:
siehe Ausklappseite E 29.

2713.

d ₂	d ₅	P	l ₁	63	71	80	90	100	110	125
10	10	1,6- 9,9	13* 19*	●	●	●	●	●		
13	12	5,0- 12,9	13 19	●	●	●	●	●	●	●
16	12	8,0- 15,9	13 19 25	●	●	●	●	●	●	●
20	12	12,0- 19,9	13 19 25	●	●	●	●	●	●	●
25	12	16,0- 24,9	13 19 25		●	●	●	●	●	●
32	12	24,0- 31,9	13 19 25		●	●	●	●	●	●
40	12	30,0- 39,9	19 25 30			●	●	●	●	●

* l₁ = 10 mm wenn P < 2,20

Bestell-Beispiel:
siehe Ausklappseite E 29.

**SNELWISSELPONSNIPPEL MET UITWERPER
ZWAAR BELASTBAAR**

Art. 2723 /33/43/53

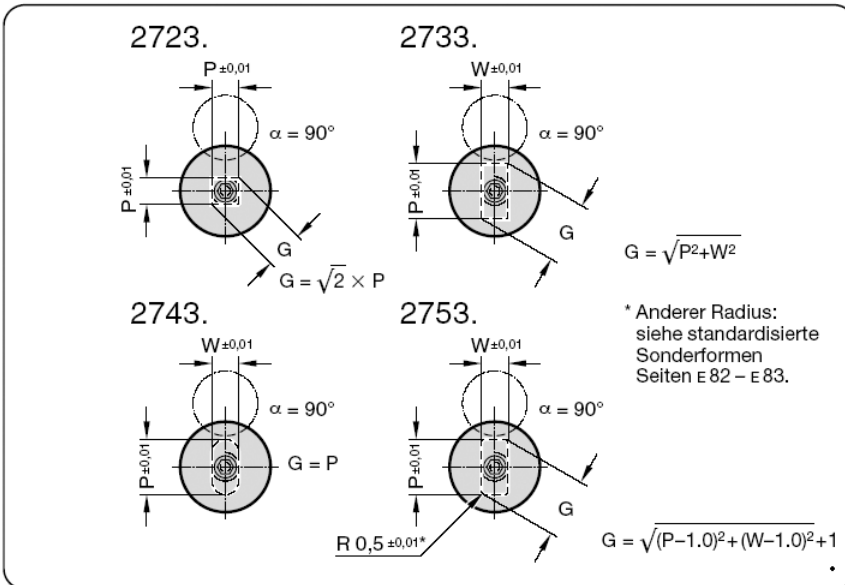

Werkstoff:

HSS
gehärtet: 62 ± 2 HRC

Ausführung:

Schaft und Schneidform feinstgeschliffen.

Andere Längen auf Anfrage.

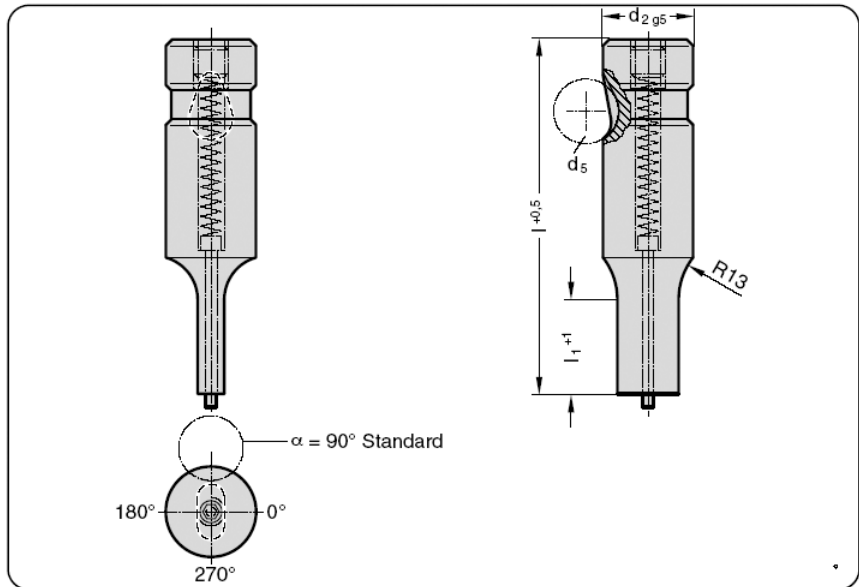

d ₂	d ₅	W _{min.}	G _{max.}	l ₁		l								
				63	71	80	90	100	110	125				
10	10	1,6	9,9	13*	19*	●	●	●	●	●				
13	12	4,5	12,9	13	19	●	●	●	●	●	●	●		
16	12	6,0	15,9	13	19	25	●	●	●	●	●	●	●	
20	12	8,0	19,9	13	19	25	●	●	●	●	●	●	●	
25	12	10,0	24,9	13	19	25	●	●	●	●	●	●	●	
32	12	12,5	31,9	13	19	25	●	●	●	●	●	●	●	
40	12	14,0	39,9	19	25	30		●	●	●	●	●	●	

* l₁ = 10 wenn P oder W < 2,20

Bestell-Beispiel:

siehe Ausklappseite E 29.

**SNELWISSELPONSNIPPEL
ZWAAR BELASTBAAR
SNIJLICHAAM > SCHACHT**

Art. 2205 /2215

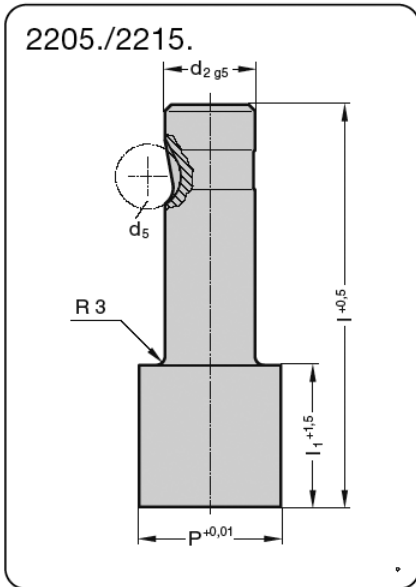

Werkstoff:
HSS
gehärtet: 62 ±2 HRC

Ausführung:
Schaft und Schneiddurchmesser
feinstgeschliffen.

Andere Längen auf Anfrage.

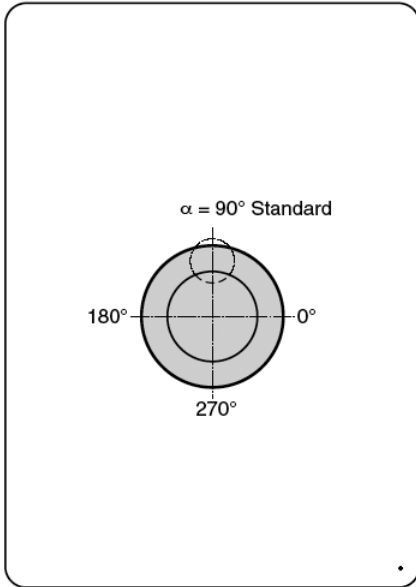
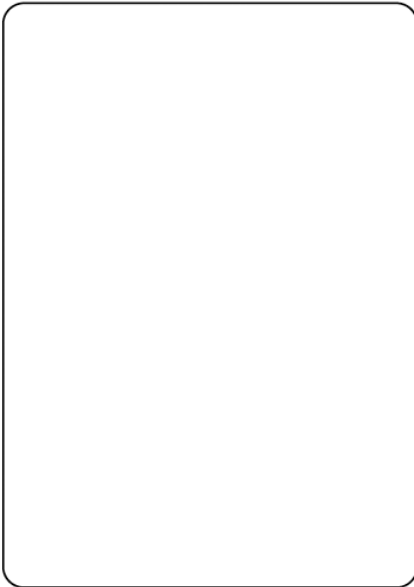

2205.

d ₂	d ₅	P	l ₁	l			
				80	90	100	
13	12	32,0	19	30	●	●	●
16	12	38,0	19	30	●	●	●
20	12	40,0	19	30	●	●	●
25	12	44,0	19	30	●	●	●
32	12	50,0	19	30	●	●	●
40	12	56,0	19	30	●	●	●

2215.

d ₂	d ₅	P	l ₁	l			
				80	90	100	
13	12	13,1 – 32,0	19	30	●	●	●
16	12	16,1 – 38,0	19	30	●	●	●
20	12	20,1 – 40,0	19	30	●	●	●
25	12	25,1 – 44,0	19	30	●	●	●
32	12	32,1 – 50,0	19	30	●	●	●
40	12	40,1 – 56,0	19	30	●	●	●

Bestell-Beispiel:
siehe Ausklappseite E 29.

Bestell-Beispiel:
siehe Ausklappseite E 29.

**SNELWISSELPONSNIPPEL
ZWAAR BELASTBAAR
SNIJLICHAAM > SCHACHT**

Art. 2225 /35/45/55

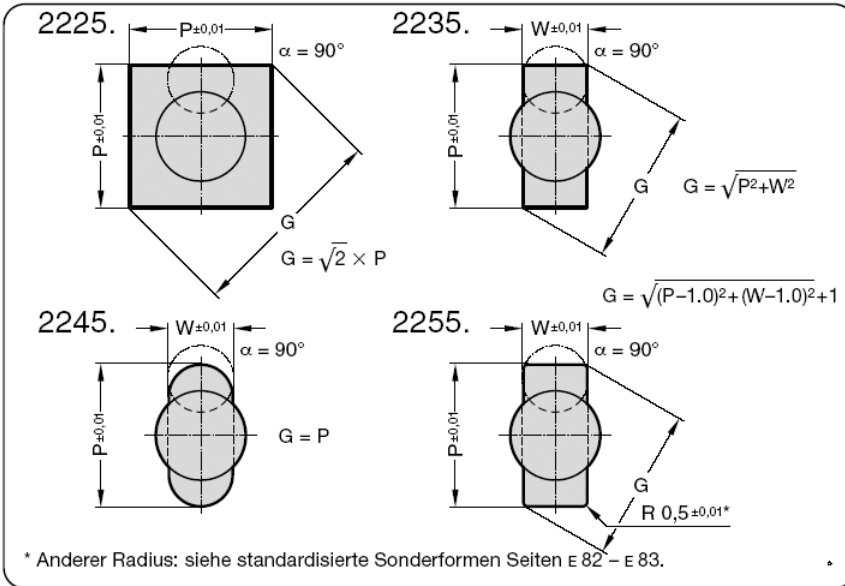

Werkstoff:
HSS
gehärtet: 62 ±2 HRC

Ausführung:
Schaft und Schneidform feinstgeschliffen.

Andere Längen auf Anfrage.

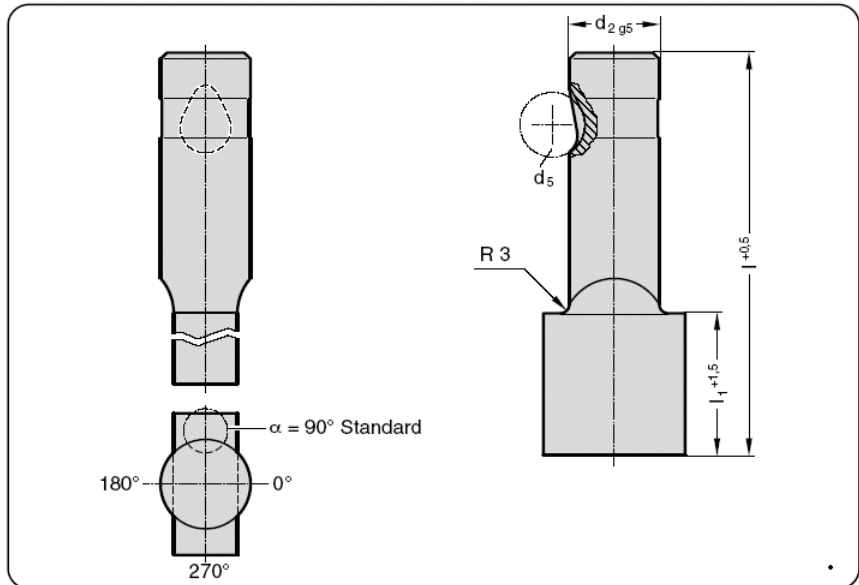

d ₂	d ₅	W _{min.}	G _{max.}	l ₁	l			
					80	90	100	
13	12	5,0	32,0	19	30	●	●	●
16	12	6,5	38,0	19	30	●	●	●
20	12	8,0	40,0	19	30	●	●	●
25	12	10,0	44,0	19	30	●	●	●
32	12	11,5	50,0	19	30	●	●	●
40	12	14,0	56,0	19	30	●	●	●

Bestell-Beispiel:
siehe Ausklappseite E 29.

**SNELWISSELPONSNIPPEL MET UITWERPER
ZWAAR BELASTBAAR
SNIJLICHAAM > SCHACHT**

Art. 2705 /2715

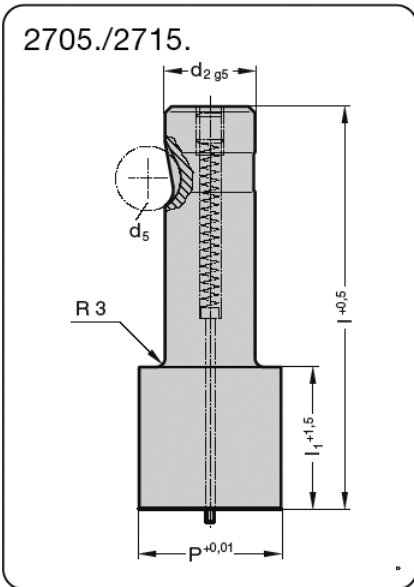

Werkstoff:
HSS
gehärtet: 62 ±2 HRC

Ausführung:
Schaft und Schneiddurchmesser
feinstgeschliffen.

Andere Längen auf Anfrage.

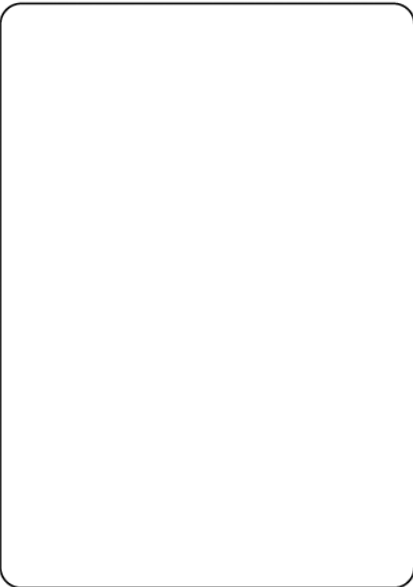
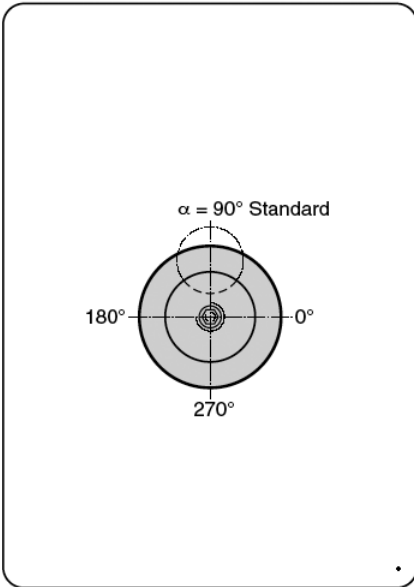

2705.

d ₂	d ₅	P	l ₁		l		
			80	90	100		
13	12	32,0	19	30	●	●	●
16	12	38,0	19	30	●	●	●
20	12	40,0	19	30	●	●	●
25	12	44,0	19	30	●	●	●
32	12	50,0	19	30	●	●	●
40	12	56,0	19	30	●	●	●

Bestell-Beispiel:
siehe Ausklappseite E 29.

2715.

d ₂	d ₅	P	l ₁		l		
			80	90	100		
13	12	13,1 – 32,0	19	30	●	●	●
16	12	16,1 – 38,0	19	30	●	●	●
20	12	20,1 – 40,0	19	30	●	●	●
25	12	25,1 – 44,0	19	30	●	●	●
32	12	32,1 – 50,0	19	30	●	●	●
40	12	40,1 – 56,0	19	30	●	●	●

Bestell-Beispiel:
siehe Ausklappseite E 29.

**SNELWISSELPONSNIPPEL MET UITWERPER
ZWAAR BELASTBAAR
SNIJLICHAAM > SCHACHT**

Art. 2725 /35/45/55

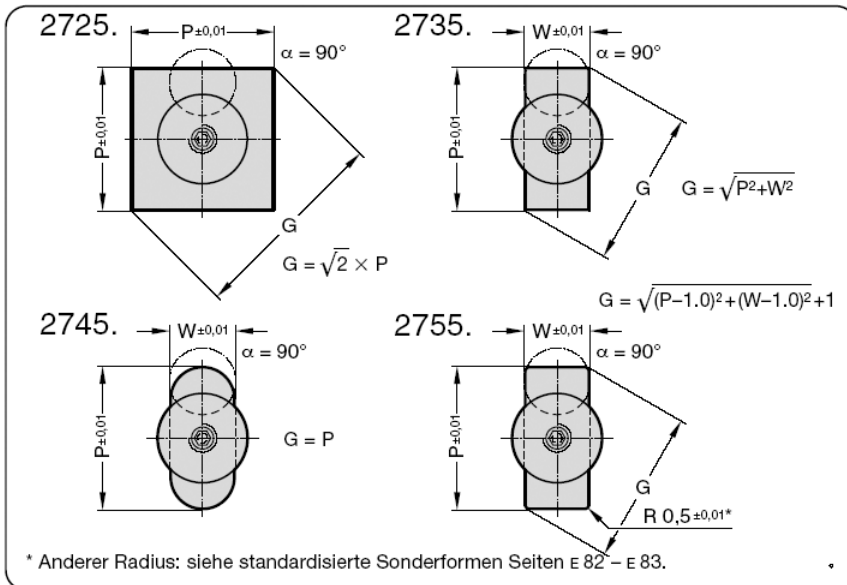

Werkstoff:

HSS
gehärtet: 62 ± 2 HRC

Ausführung:

Schaft und Schneidform feinstgeschliffen.

Andere Längen auf Anfrage.

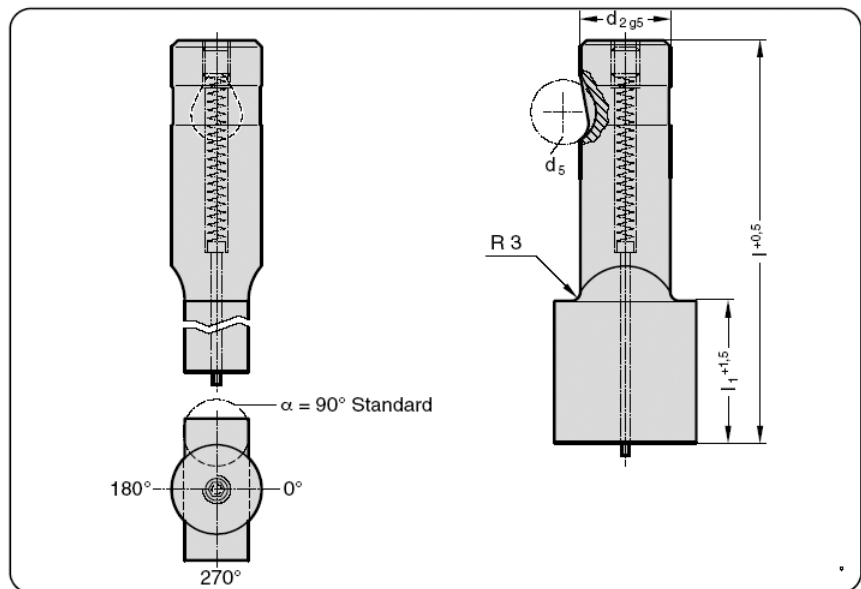

d_2	d_5	$W_{min.}$	$G_{max.}$	l_1	l		
					80	90	100
13	12	5,0	32,0	19 30	●	●	●
16	12	6,5	38,0	19 30	●	●	●
20	12	8,0	40,0	19 30	●	●	●
25	12	10,0	44,0	19 30	●	●	●
32	12	11,5	50,0	19 30	●	●	●
40	12	14,0	56,0	19 30	●	●	●

Bestell-Beispiel:

siehe Ausklappseite E 29.