

AFSTRIJKER

Art. 2431.7

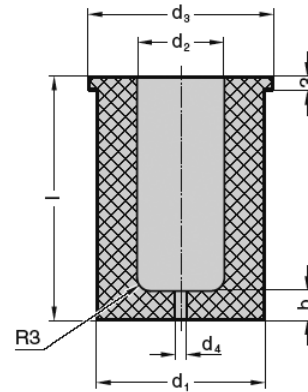

2431.7.



Werkstoff:

FIBROFLEX® 95 Shore A, rot

Hinweis:

Die Abstreifer können für die Aufnahmeplatten 2664.02./04./05./06. verwendet werden.

d ₂	Abstreiferlänge l				
	35	43	53	63	73
10	●	●	●	●	●
13	●	●	●	●	●
16	●	●	●	●	●
20	●	●	●	●	●
25	●	●	●	●	●
32	●	●	●	●	●
38	●	●	●	●	●
40	●	●	●	●	●

	Einsetzbare Schneidstempellängen				
	63	71	80	90	100
Schnellwechselschneidstempel, leicht	63	71	80	90	100
Schnellwechselschneidstempel, schwer	71	80	90	100	110
Präzisionsschneidstempel ISO 8020	-	71	80	90	100

Einbaubeispiel:

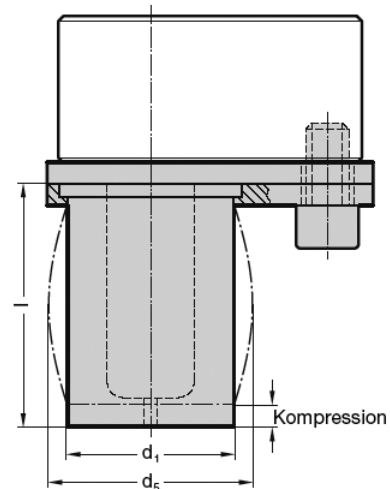

2431.7.

d ₂	d ₁	d ₃	d ₄	d _{5 max.}	b	l				
						35	43	53	63	73
10	18	21	3	22	6	●	●	●	●	●
13	23	26	3	26,5	6	●	●	●	●	●
16	30	33	3	34	6	●	●	●	●	●
20	33	36	3	38	7	●	●	●	●	●
25	40	43	3	47,6	7	●	●	●	●	●
32	50	54	4	57,9	7	●	●	●	●	●
38	60	64	4	69,6	8	●	●	●	●	●
40	60	64	4	69,6	8	●	●	●	●	●

* Werte für Abstreiferkraft sind von verschiedenen Parametern abhängig (z.B. Schmiermittel, Temperatur etc.) und können von den hier angegebenen abweichen!
 **max. Federweg sollte 15% der Länge nicht überschreiten

Bestell-Beispiel:

Abstreifer = 2431.7.
 d₂ = 10 mm = 10.
 l = 53 mm = 53
 Bestell-Nummer = 2431.7.10.53

d ₂	Abstreiferkräfte (N)*																	
	Länge	3mm	6mm	9mm	3mm	6mm	9mm	3mm	6mm	9mm	3mm	6mm	9mm	3mm	6mm	9mm		
10	1300	**	**	1000	1700	**	900	1400	**	700	1200	1600	-	-	-			
13	2100	**	**	1700	2700	**	1400	2200	**	1200	1900	2400	1000	1600	2000			
16	3000	**	**	2500	4000	**	2000	3200	**	1700	2700	3500	1500	2400	3000			
20	3500	**	**	2900	4700	**	2400	3800	**	2000	3200	4100	1700	2700	3600			
25	5400	**	**	4400	7100	**	3600	5800	**	3000	4900	6300	2600	4200	5500			
32	8400	**	**	6800	10900	**	5500	8800	**	4700	7500	9700	4000	6400	8400			
38	-	-	-	-	-	**	7000	10400	**	6100	9200	12300	5000	7600	10100			
40	-	-	-	10400	16600	**	8500	13600	**	7000	11300	14800	6000	9800	127000			

STEUN VOOR AFSTRIJKER

Art. 2667.1 /2

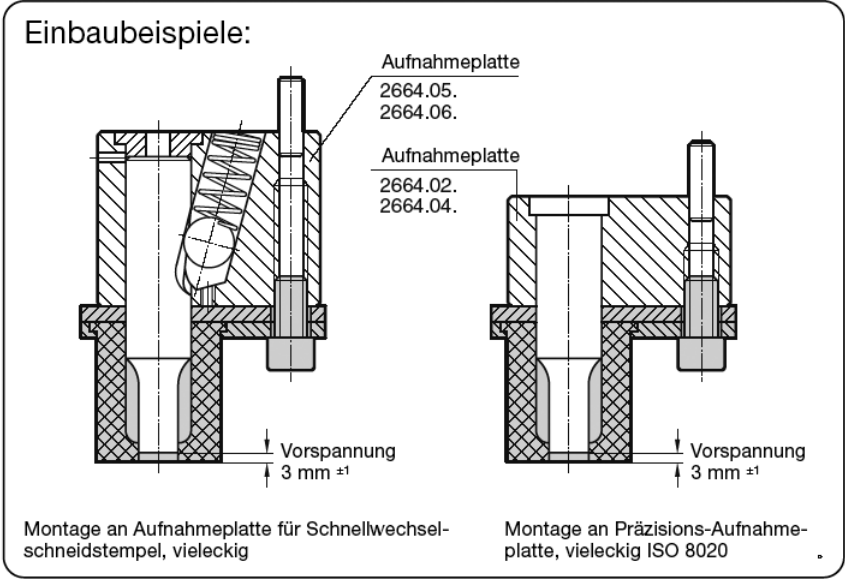
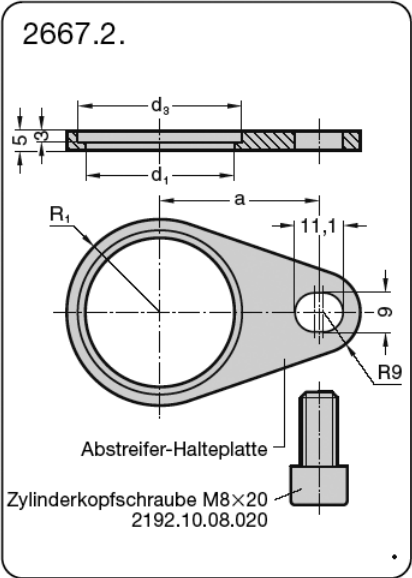
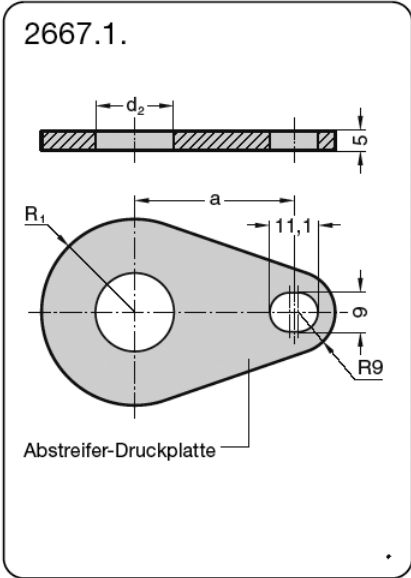

Hinweis:
Druckplatte, Halteplatte und Schraube
müssen als Einzelteile bestellt werden.

2667.1/2.

d ₂	d ₁	d ₃	R ₁	a
10	18	21	13	28
13	23	26	15,5	31
16	30	33	18	32,9
20	33	36	20,5	34,8
25	40	43	24	39,8
32	50	54	31	41,3
38	60	64	36	44
40	60	64	36	44

Bestell-Beispiel:

Abstreifer Haltegarnitur = 2667.
 Typ = 1.
 d₂ = Ø10mm = 010
 Bestell-Nummer = 2667.1.010