

**SPANHAAK MET FLENS**

**K.0015**



**MATERIAAL :**  
staal, behandeld en gebruind.

**OPMERKING :**  
Deze spanhaken kunnen direct in platen met getapte gaten gemonteerd worden zonder kamering.  
Ze kunnen gemonteerd worden op de tussenstukken Ref. K.0018.

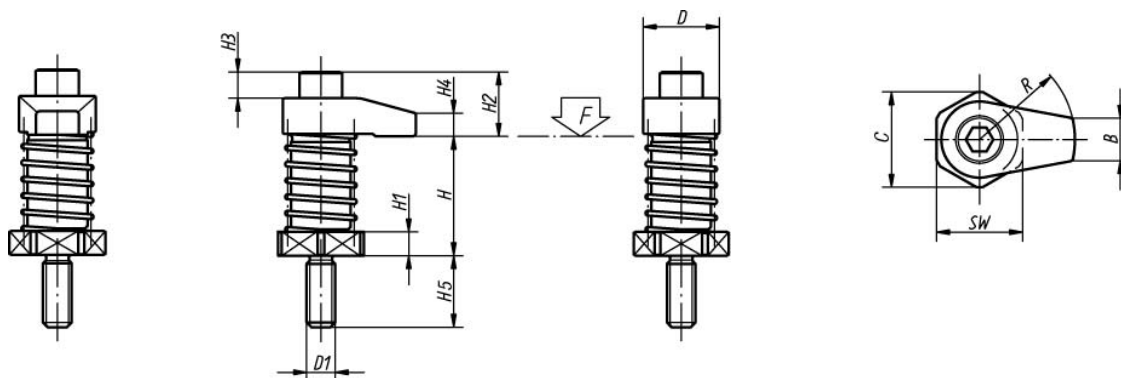

D	D1	H (opspannen)	H1	H2	H3	H4	H5	B	C	R	SW	Kopel (N/m)	Kracht (daN)	Ref.
22	M8	35 - 45	6	14	2	7	19	10	25	20	22	34,3	790	K.0015.08020
22	M8	35 - 45	6	14	2	7	19	10	25	25	22	30,4	730	K.0015.08025
22	M8	35 - 45	6	14	2	7	19	10	25	30	22	27,4	670	K.0015.08030
22	M8	45 - 55	16	14	2	7	19	10	25	20	22	34,3	790	K.0015.08120
22	M8	45 - 55	16	14	2	7	19	10	25	25	22	30,4	730	K.0015.08125
22	M8	45 - 55	16	14	2	7	19	10	25	30	22	27,4	670	K.0015.08130
32	M12	50 - 65	10	27	11	10	30	18	40	40	36	58,8	1.350	K.0015.12040
32	M12	50 - 65	10	29	11	12	30	18	40	50	36	50	1.260	K.0015.12050
32	M12	50 - 65	10	29	11	12	30	18	40	60	36	45,1	1.170	K.0015.12060
32	M12	65 - 80	25	27	11	10	30	18	40	40	36	58,8	1.350	K.0015.12140
32	M12	65 - 80	25	29	11	12	30	18	40	50	36	50	1.260	K.0015.12150
32	M12	65 - 80	25	29	11	12	30	18	40	60	36	45,1	1.170	K.0015.12160
36	M16	50 - 65	10	36	15	15	30	22	40	40	36	169,1	1.340	K.0015.16040
36	M16	50 - 65	10	36	15	15	30	22	40	50	36	146	1.240	K.0015.16050
36	M16	50 - 65	10	36	15	15	30	22	40	60	36	129,4	1.200	K.0015.16060
36	M16	65 - 80	25	36	15	15	30	22	40	40	36	169,4	1.340	K.0015.16140
36	M16	65 - 80	25	36	15	15	30	22	40	50	36	146	1.240	K.0015.16150
36	M16	65 - 80	25	36	15	15	30	22	40	60	36	129,4	1.200	K.0015.16160