

SPANKLAUW OP HOEKSOKKEL

KWN.4374

MATERIAAL EN UITVOERING :
 klauw en spanvijs uit behandeld staal, gebruind

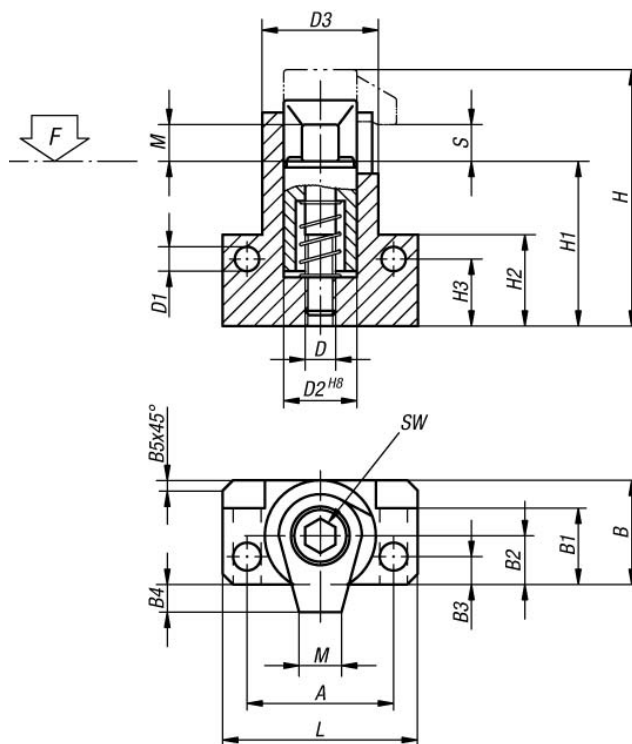

VOORBEELD VAN TOEPASSING :

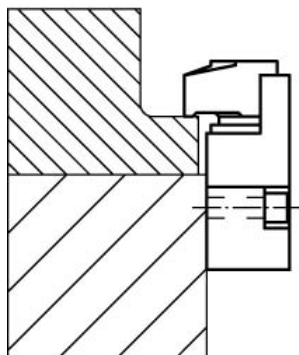

D	D1	D2	D3	A	B	B1	B2	B3	B4	B5	H	H1	H2	H3	L	M	S	SW	KOPPEL MAX. (Nm)	F MAX. (kN)	Ref.
M8	6,4	20	28	38	26	19,5	12	6	6	2,5	62	47,5	25	18	50	10	4	6	30	17	KWN.4374.08
M10	8,4	24	34	48	31	22,5	14	7,5	9	3	74	57,5	30	21	64	12	5	8	50	18	KWN.4374.10
M12	10,5	28	40	55	36,5	26	16,5	9	10,5	3,5	87	67	35	24	75	15	5	10	60	20	KWN.4374.12
M16	12,8	34	48	65	43,5	31	19,5	10	16,5	4	112	87	45	32	88	20	5	14	120	24	KWN.4374.16