

## VEERGRENDEL

FFM.SF...

MATERIAAL EN UITVOERING : verzinkt staal, lasbaar

Op aanvraag : uit RVS

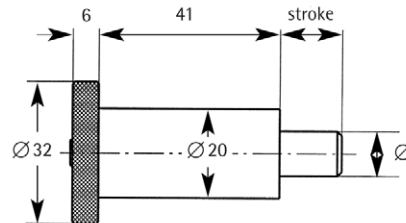

Ref. FFM.SF... : met glad lichaam Ø 20 mm.

Ø	slaglengte	Ref.
8	14	FFM.SF.08.14
10	10	FFM.SF.10.10
10	14	FFM.SF.10.14
12	14	FFM.SF.12.14
15	14	FFM.SF.15.14

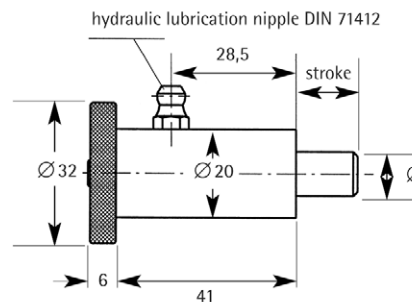

Ref. FFM.SFN... :

met glad lichaam Ø 20 mm en smeernippel

Ø	slaglengte	Ref.
8	14	FFM.SFN.10.10
10	10	FFM.SFN.10.10
10	14	FFM.SFN.10.14
12	14	FFM.SFN.12.14
15	14	FFM.SFN.15.14

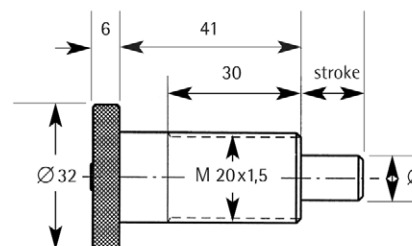

Ref. FFM.SFG... :

met draadlichaam Ø 20 mm

Ø	slaglengte	Ref.
8	14	FFM.SFG.10.10
10	10	FFM.SFG.10.10
10	14	FFM.SFG.10.14
12	14	FFM.SFG.12.14
15	14	FFM.SFG.15.14

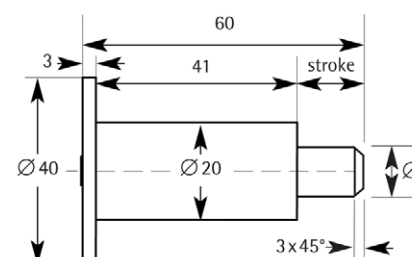

Ref. FFM.SF.1115 :

met glad lichaam Ø 20 mm, slaglengte : 15 mm.

## VEERGRENDEL

**FFM.F...**

### MATERIAAL EN UITVOERING :

Verzinkt staal, ontgrendeling door aan de kartelknop te trekken.

Op aanvraag : uit RVS



OP AANVRAAG

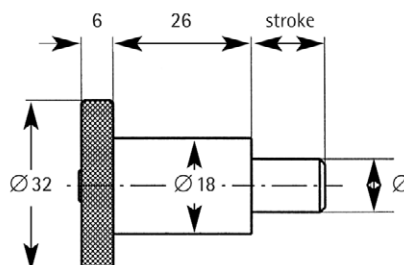

Ref. FFM.F... : met glad lichaam Ø 18 mm.

Ø	slaglengte	Ref.
8	10	<b>FFM.F.08.10</b>
10	10	<b>FFM.F.10.10</b>
12	10	<b>FFM.F.12.10</b>

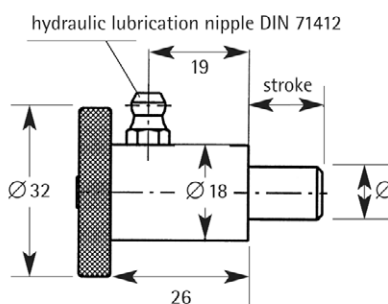

Ref. FFM.FN... :

met glad lichaam Ø 18 mm en smeernippel

Ø	slaglengte	Ref.
8	10	<b>FFM.FN.08.10</b>
10	10	<b>FFM.FN.10.10</b>
12	10	<b>FFM.FN.12.10</b>

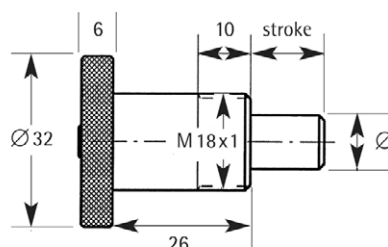

Ref. FFM.FG... :

met draadlichaam M18 x 1

Ø	slaglengte	Ref.
8	10	<b>FFM.FG.08.10</b>
10	10	<b>FFM.FG.10.10</b>
12	10	<b>FFM.FG.12.10</b>

## VEERGRENDEL

FFM.F...

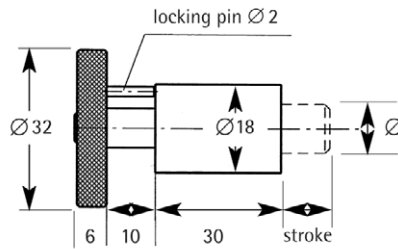

Ref. FFM.FA... :  
met glad lichaam Ø 18 mm  
en blokkeerstift Ø 2 mm

Ø	slaglengte	Ref.
8	10	FFM.FA.08.10
10	10	FFM.FA.10.10
12	10	FFM.FA.12.10

Ref. FFM.FM.0066 : knop uit aluminium.

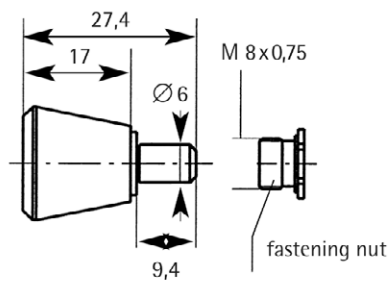

## VEERGRENDEL MET KNOP

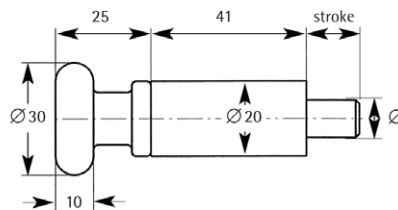
**FFM.SK GK...**
**MATERIAAL EN UITVOERING :** verzinkt staal, lasbaar.

**Ref. FFM.SK GK...** :  
met glad lichaam Ø 20 mm

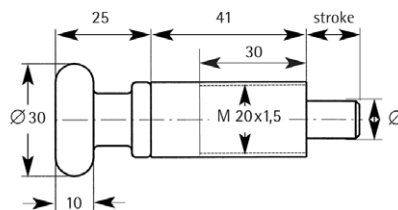
Ø	slaglengte	Ref.
8	14	<b>FFM.SK GK.08.14</b>
10	10	<b>FFM.SK GK.10.10</b>
10	14	<b>FFM.SK GK.10.14</b>
12	14	<b>FFM.SK GK.12.14</b>
15	14	<b>FFM.SK GK.15.14</b>

**Ref. FFM.SK GK...** :  
met draadlichaam M20 x 1,5

Ø	slaglengte	Ref.
8	14	<b>FFM.SK GK.08.14</b>
10	10	<b>FFM.SK GK.10.10</b>
10	14	<b>FFM.SK GK.10.14</b>
12	14	<b>FFM.SK GK.12.14</b>
15	14	<b>FFM.SK GK.15.14</b>

**MATERIAAL EN UITVOERING :**

- Ref. BKE.36.0028... : lichaam en stift uit verzinkt staal, niet vergrendelbaar.
- Ref. BKE.36.0029... : lichaam en stift uit RVS 1.4305, niet vergrendelbaar
- Ref. BKE.36.0030... : lichaam en stift uit verzinkt staal, vergrendelbaar.
- Ref. BKE.36.0031... : lichaam en stift uit RVS 1.4305, vergrendelbaar.

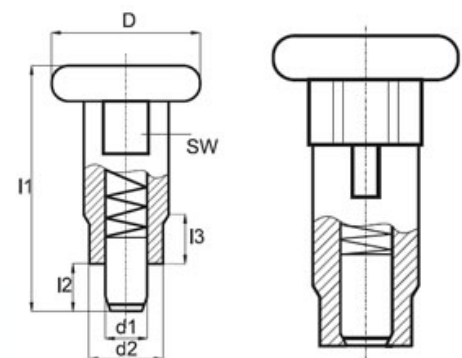
 d 2 = M10 zeskant lichaam  
 d 2 = M12 met rond lichaam

**ECLIPSABLE**
**OM TE BESTELLEN :**

Ref. BKE.36.0028, D = 18 = Ref. BKE.36.0028.18

Ref. BKE.36.0031, D = 24 = Ref. BKE.36.0031.24

## VEERGRENDEL

FFM.SK

MATERIAAL EN UITVOERING : verzinkt staal, lasbaar ; ontgrendeling door trekbeweging.  
Op aanvraag : uit RVS



OP AANVRAAG

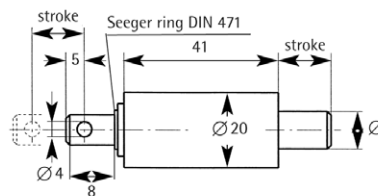

Ref. FFM.SK... :

met glad lichaam Ø 20 mm, trekuiteinde met gat Ø 4 mm. Op aanvraag : kettinkje

Ø	slaglengte	Ref.
8	14	FFM.SK.08.14
10	10	FFM.SK.10.10
10	14	FFM.SK.10.14
12	14	FFM.SK.12.14
15	14	FFM.SK.15.14

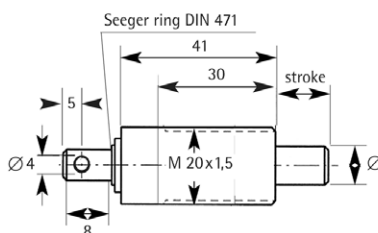

Ref. FFM.SKM... :

met glad lichaam Ø 20 mm, trekuiteinde M8.

Ø	slaglengte	Ref.
8	14	FFM.SKM.08.14
10	10	FFM.SKM.10.10
10	14	FFM.SKM.10.14
12	14	FFM.SKM.12.14
15	14	FFM.SKM.15.14

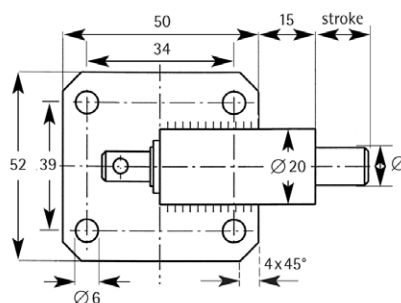

Ref. FFM.SKP... :

met glad lichaam Ø 20 mm, op plaatje 2 mm dikte

Ø	slaglengte	Ref.
8	14	FFM.SKP.08.14
10	10	FFM.SKP.10.10
10	14	FFM.SKP.10.14
12	14	FFM.SKP.12.14
15	14	FFM.SKP.15.14

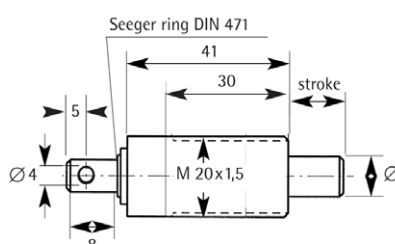

Ref. FFM.SKG... :

met draadlichaam M10 x 1,5, trekuiteinde met gat Ø 4 mm. Op aanvraag : kettinkje

Ø	slaglengte	Ref.
8	14	FFM.SKG.08.14
10	10	FFM.SKG.10.10
10	14	FFM.SKG.10.14
12	14	FFM.SKG.12.14
15	14	FFM.SKG.15.14