

## RONDE PLAAT UIT GIETIJZER

**WWN.904**

MATERIAAL : gietijzer EN 1561.

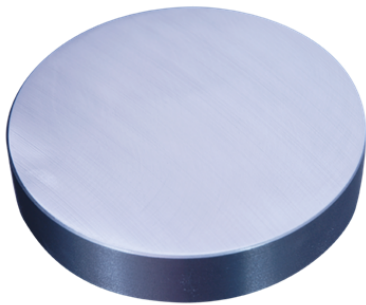

D	E	gewicht (kg)	Ref.
100	20	1,1	<b>WWN.904.403</b>
125	25	2,3	<b>WWN.904.404</b>
150	25	3,2	<b>WWN.904.445</b>
160	32	4,6	<b>WWN.904.405</b>
200	32	7,2	<b>WWN.904.406</b>
200	63	14	<b>WWN.904.407</b>
250	36	13	<b>WWN.904.4085</b>
315	45	25	<b>WWN.904.410</b>
400	45	41	<b>WWN.904.412</b>
500	50	71	<b>WWN.904.4145</b>
630	50	112	<b>WWN.904.4165</b>
800	56	203	<b>WWN.904.418</b>
1000	63	356	<b>WWN.904.419</b>

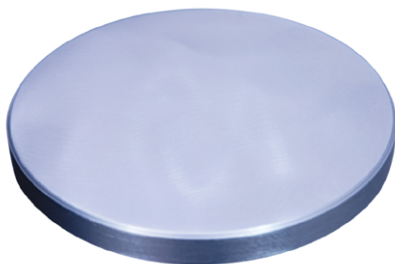
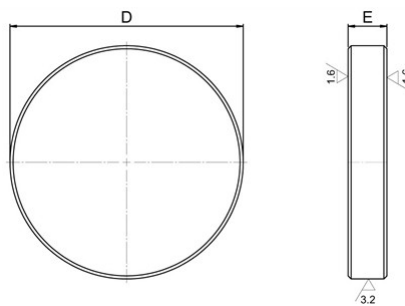

D	E	gewicht (kg)	Ref.
125	12	1,2	<b>WWN.905.403</b>
125	16	1,5	<b>WWN.905.404</b>
160	16	2,5	<b>WWN.905.405</b>
160	20	3,1	<b>WWN.905.406</b>
200	16	3,9	<b>WWN.905.407</b>
200	20	4,9	<b>WWN.905.408</b>
250	25	9,6	<b>WWN.905.410</b>
315	22	13,5	<b>WWN.905.411</b>
315	28	17	<b>WWN.905.412</b>
400	25	25	<b>WWN.905.413</b>

